

ABB INDUSTRIAL DRIVES

# ACS880-37 drives (45...400 kW, 60...450 hp)





Hardware manual



—

# ACS880-37 drives (45...400 kW, 60...450 hp)

Hardware manual

Table of contents	
1. Safety instructions	
4. Mechanical installation	
6. Electrical installation	
10. Start-up	



# Table of contents

---

## 1. Safety instructions

Contents of this chapter .....	15
Use of warnings and notes .....	15
General safety in installation, start-up and maintenance .....	16
Electrical safety in installation, start-up and maintenance .....	19
Electrical safety precautions .....	19
Additional instructions and notes .....	23
Additional instruction for DC connection .....	24
Grounding .....	24
Additional instructions for permanent magnet motor drives .....	26
Safety in installation, start-up and maintenance .....	26

## 2. Introduction to the manual

Contents of this chapter .....	27
Target audience .....	27
Contents of the manual .....	27
Related documents .....	28
Categorization by frame size and option code .....	29
Quick installation, commissioning and operation flowchart .....	30
Terms and abbreviations .....	31

## 3. Operation principle and hardware description

Contents of this chapter .....	33
Operation principle .....	33
Single-line circuit diagram of the drive .....	34
Single-line diagram of R8 .....	34
Single-line diagram of R11 .....	35
of the drive with brake options +D150 and +D151 .....	36
Line-side converter .....	37
AC voltage and current waveforms .....	37
Charging .....	37
Motor-side converter .....	37
Cabinet layout .....	38
Cabinet layout of R8 .....	38
Cabinet layout of R11 .....	41
Overview of power and control connections .....	47
Connection overview of R8 .....	47
Connection overview of R11 .....	48
External control cable connection terminals .....	50
Connection terminals of R8 .....	50
Connection terminals of R11 .....	51
Door switches and lights .....	52
Main disconnecting device (Q1) .....	52
Other devices on the door .....	53
Control panel .....	53
Control by PC tools .....	53

---



Descriptions of cabinet options	54
Degree of protection	54
Definitions	54
IP22 (standard)	54
IP42 (option +B054)	54
IP54 (option +B055)	54
Channeled air inlet through bottom (option +C128)	54
Channeled air outlet (option +C130)	54
Marine construction (option +C121)	55
UL listed (option +C129)	55
Plinth height (options +C164 and +C179)	55
Seismic design (option +C180)	55
Resistor braking (options +D150 and +D151)	55
Empty cubicles (options +C196, +C197, +C198, +C199, +C200, +C201)	56
EMC filters (option + E202)	56
du/dt filter (option +E205)	56
Sine filter (option +E206)	56
Common mode filter (option +E208)	56
Cabinet heater with external supply (option +G300)	56
Cabinet lighting (option +G301)	57
Terminals for external interruptible control voltage (option +G307)	57
Output for motor space heater (option +G313)	57
Ready/Run/Fault lights (options +G327...G329)	57
Halogen-free materials and wiring (option G330)	57
V-meter with selector switch (option +G334)	57
A-meter in one phase (option +G335)	58
Additional wire markings (options +G340 and +G342)	58
Standard wire markings	58
Bottom cable entry/exit (options +H350 and +H352)	58
Top cable entry/exit (options +H351 and +H353)	59
Cable conduit entry (option +H358)	59
Additional terminal block X504 (option +L504)	59
Thermal protection with PTC relays (options +L505, +2L505, +L513, +2L513)	59
+L505, +2L505, +L513, +2L513	59
+L536, +L537	60
More information	60
Pt100 relays (options +2L506, +3L506, +5L506, +8L506, +L514)	60
Starter for auxiliary motor fan (options +M600...+M605)	61
What the option contains	61
Description	61
Type designation label	62
Type designation key	63

#### **4. Mechanical installation**

Contents of this chapter	67
Examining the installation site	67
Necessary tools	68
Checking the delivery	68
Moving and unpacking the drive	69
Moving the drive in its packaging	69
Moving the crate with a forklift	70
Removing the transport package	71
Moving the unpacked drive cabinet	71

Lifting the cabinet with a crane	71
Moving the cabinet on rollers	72
Moving the cabinet on its back	72
Final placement of the cabinet	73
Installing the IP54 roof (option +B055)	74
Frame R8	74
Frame R11	75
Attaching the cabinet to the floor and wall or roof	76
General rules	76
Attaching methods	77
Alternative 1 – Clamping	77
Alternative 2 – Using the holes inside the cabinet	77
Attaching the cabinet to the floor and wall or roof (marine units)	78
Miscellaneous	79
Cable duct in the floor below the cabinet	79
Air inlet through the bottom (option +C128)	79
Air outlet duct on the cabinet roof (option +C130)	80
Calculating the required static pressure difference	80
Arc welding	80



## **5. Guidelines for planning the electrical installation**

Contents of this chapter	83
Limitation of liability	83
Selecting the supply disconnecting device	83
Examining the compatibility of the motor and drive	83
Protecting the motor insulation and bearings	84
Requirements table	85
Additional requirements for explosion-safe (EX) motors	86
Additional requirements for ABB motors of types other than M2_, M3_, M4_, HX_ and AM_	87
Additional requirements for the regenerative and low harmonic drives	87
Additional requirements for braking applications	87
Additional requirements for ABB high-output and IP23 motors	87
Additional requirements for non-ABB high-output and IP23 motors	87
Additional data for calculating the rise time and the peak line-to-line voltage	89
Additional note for sine filters (option +E206)	89
Selecting the power cables	90
General rules	90
Typical cable sizes	91
Alternative power cable types	92
Recommended power cable types	92
Power cable types for limited use	92
Not allowed power cable types	93
Motor cable shield	93
Additional US requirements	93
Conduit	93
Armored cable / shielded power cable	94
Planning the braking system	94
Selecting the control cables	95
Shielding	95
Signals in separate cables	95
Signals allowed to be run in the same cable	95
Relay cable type	95

Control panel cable length and type .....	95
Routing the cables .....	96
Separate control cable ducts .....	96
Continuous motor cable shield or enclosure for equipment on the motor cable ....	97
Implementing thermal overload and short-circuit protection .....	97
Protecting the drive and input power cable in short-circuits .....	97
R8 .....	97
R11 .....	97
Protecting the motor and motor cable in short-circuits .....	97
Protecting the drive and the power cables against thermal overload .....	98
Protecting the motor against thermal overload .....	98
Implementing a ground fault detection function .....	98
Residual current device compatibility .....	98
Implementing the emergency stop function .....	98
Implementing the Safe torque off function .....	99
Implementing the ATEX-certified Safe motor disconnection function (option +Q971) ..	99
Implementing the Prevention of unexpected start-up function .....	99
Implementing the functions provided by the FSO-xx safety functions module (option +Q972 or +Q973) .....	99
Declaration of Conformity .....	100
Implementing the Power-loss ride-through function .....	100
Supplying power for the auxiliary circuits .....	100
Using power factor compensation capacitors with the drive .....	101
Implementing a safety switch between the drive and the motor .....	101
Using a contactor between the drive and the motor .....	101
Implementing a bypass connection .....	102
Protecting the contacts of relay outputs .....	102
Implementing a motor temperature sensor connection .....	103
Connection of motor temperature sensor to the drive via an option module .....	103
Connection of motor temperature sensor to the drive via a relay .....	104

## 6. Electrical installation

Contents of this chapter .....	105
Warnings .....	105
Checking the insulation of the assembly .....	105
Drive .....	105
Input cable .....	105
Motor and motor cable .....	106
Checking the compatibility with IT (ungrounded), corner-grounded delta, midpoint- grounded delta and TT systems .....	106
EMC filter (options +E200 or +E202) .....	106
Ground-to-phase varistor .....	107
Corner-grounded and midpoint-grounded 690 V delta systems .....	107
Attaching the device stickers to the cabinet door .....	107
Checking the settings of auxiliary voltage transformers .....	107
Connecting the control cables .....	108
Control cable connection procedure .....	108
Grounding the outer shields of the control cables at the cabinet entry .....	109
Routing the control cables inside the cabinet .....	111
Connecting to the drive control unit .....	116
Connecting an auxiliary voltage supply (UPS, option +G307) .....	117
Connecting emergency stop push buttons (options +Q951, +Q952, +Q963, +Q964, +Q978, +Q979) .....	117





Wiring the starter for auxiliary motor fan (options +M600...+M605)	117
Wiring the PTC thermistor relay(s) (options +L505, +2L505, +L513, +2L513)	118
Wiring the Pt100 relays (option +nL506)	119
Wiring the Pt100 relays (option +nL514)	120
Powering the heating and lighting equipment (options +G300, +G301 and +G313)	121
Wiring ground fault monitoring for IT ungrounded systems (option +Q954)	122
Connecting the power cables	123
Connection diagram	123
Connection diagram of frame R8	123
Connection diagram of frame R11	124
Layout of power cable connection terminals and cable entries	126
Frame R8	126
Frame R11	127
Layout of power cable connection terminals (option +C129)	128
External resistor cable connection terminals and cable entries	129
Connection procedure (IEC)	129
Connection procedure (US)	132
Grounding the motor cable shield at the motor end	133
Connecting a PC	134
Installing option modules	135
Mechanical installation of I/O extension, fieldbus adapter and pulse encoder interface modules	135
Installation of safety functions modules (frame R8)	136
Installation of safety functions modules (frame R11)	137
Case 1: FSO-xx safety functions module on Slot 2	137
Case 2: FSO-xx safety functions module next to the control unit	139

## 7. Control unit of frame R8

Contents of this chapter	141
Layout	142
Default I/O connection diagram of frame R8	143
Jumpers and switches	144
External power supply for the control unit (XPOW)	144
AI1 and AI2 as Pt100, Pt1000, PTC and KTY84 sensor inputs (XAI, XAO)	145
DI6 (XDI:6) as PTC sensor input	146
DIIL input (XD24:1)	146
The XD2D connector	146
Safe torque off (XSTO)	147
FSO-xx safety functions module connection (X12)	147
Technical data	147

## 8. Control unit of frame R11

Contents of this chapter	151
Layout	152
Default I/O connection diagram of frame R11	153
Jumpers and switches	154
External power supply for the control unit (XPOW)	154
AI1 and AI2 as Pt100, Pt1000, PTC and KTY84 sensor inputs (XAI, XAO)	155
DI6 (XDI:6) as PTC sensor input	156
DIIL input (XD24:1)	156
The XD2D connector	156



Safe torque off (XSTO) .....	157
FSO-xx safety functions module connection (X12) .....	157
Technical data .....	157

## 9. Installation checklist

Contents of this chapter .....	161
Warnings .....	161
Checklist .....	161

## 10. Start-up

Contents of this chapter .....	163
Start-up procedure .....	163
Safety .....	164
Checks/Settings with no voltage connected .....	164
Powering up the auxiliary circuit of the drive .....	164
Setting up the line-side converter parameters .....	165
Setting up the motor-side converter parameters, and performing the first start ..	165
Activating the Run enable signal of the line-side converter (with options +Q951, +Q952 and +Q978) .....	165
On-load checks .....	165

## 11. Fault tracing

Contents of this chapter .....	167
LEDs .....	167
Warning and fault messages .....	167

## 12. Maintenance

Contents of this chapter .....	169
Maintenance intervals .....	169
Descriptions of symbols .....	170
Recommended annual maintenance actions by the user .....	170
Recommended maintenance intervals after start-up .....	170
Cabinet .....	171
Cleaning the interior of the cabinet .....	171
Cleaning the door air inlets (IP22 and IP42) .....	171
Cleaning the door air inlets (IP54) .....	172
Cleaning the outlet (roof) filters (IP54) .....	172
Replacing the outlet (roof) filters (IP54) .....	172
Heatsink .....	173
Power connections .....	173
Retightening the power connections .....	173
Fans .....	174
Replacing the cabinet "door fan" .....	174
Replacing the internal cabinet cooling fans (frame R8) .....	175
Replacing the drive module main fan (frame R8) .....	177
Replacing the drive module main fans (frame R11) .....	178
Replacing the LCL filter module fan (frame R11) .....	180
Replacing the auxiliary cooling fan of the drive module (frame R8) .....	181
Replacing the auxiliary cooling fans of the drive module (frame R11) .....	182
Frame R8: Replacing the IP54 (UL Type 12) roof fan and brake chopper (option	



+D150) cubicle fan G101.2	184
Frame R11 with options +B055 and +C128: Replacing the roof fan	185
Frame R11 with option +B055: Replacing the roof fan	186
Replacing the brake chopper (option +D150) cubicle fan	187
Replacing the sine filter cooling fan	187
Replacing the drive module (frame R8)	188
Required tools	188
Safety	188
Replacing the drive and LCL filter modules (frame R11)	197
Required tools	197
Safety	197
Replacing the drive module (frame R11)	197
Replacing the LCL filter module	207
Capacitors	208
Reforming the capacitors	208
Fuses	209
Replacing fuses (frame R8)	209
Replacing fuses (frame R11)	210
Control panel	212
Replacing the battery	212
Cleaning	212
Replacing the control unit battery	213
Memory unit	214
Replacing the memory unit of the motor-side converter control unit (frame R8)	214
Replacing the memory unit of the motor-side converter control unit (frame R11)	215
Replacing the memory unit of the line-side converter control unit (frame R11)	216

### 13. Technical data

Contents of this chapter	217
Marine type-approved drives (option +C132)	217
Ratings	217
IEC ratings	217
UL (NEC) ratings	218
Definitions	219
Derating	220
Ambient temperature derating	220
Altitude derating	221
Deratings for special settings in the drive control program	221
Ex motor, sine filter, low noise	221
High speed mode	223
Fuses (IEC)	224
Fuses (UL)	225
Dimensions and weights	226
Dimensions and weights of sine filter cabinet (option +E206)	226
Free space requirements	227
Cooling data, noise	228
Sine output filter data	229
Terminal and exit data for the power cables	230
IEC	230
Terminal data for the drive control unit	230
Electrical power network specification	231
Motor connection data	232
Control unit connection data	232



Efficiency	232
Protection classes	232
Ambient conditions	232
Auxiliary circuit power consumption	233
Materials	234
CE marking	235
Compliance with the European Low Voltage Directive	235
Compliance with the European EMC Directive	235
Compliance with the European Machinery Directive	235
Applicable standards	235
EU Declaration of Conformity	236
Compliance with EN 61800-3:2004 + A1:2012	238
Definitions	238
Category C2	238
Category C3	238
Category C4	239
UL marking	239
UL checklist	239
CSA marking	240
RCM marking	240
The KC (Korea Certification) marking	241
WEEE marking	241
EAC (Eurasian Conformity) marking	241
EIP (Electronic Information Products) marking	241
Tightening torques	241
Electrical connections	241
Mechanical connections	241
Insulation supports	241
Cable lugs	242
Disclaimers	242
Generic disclaimer	242
Cybersecurity disclaimer	242

#### 14. Dimensions

Contents of this chapter	243
R8: IP22 (UL Type 1), option +B054 (IP42 [UL Type 1 Filtered])	244
R8 (IP54, UL Type 12, option +B055): option +C129	245
R8 IP22 (UL Type 1) and IP42 (UL Type 1 Filtered, option +B054): options +D150, +D151	246
R8 IP22 (UL Type 1) and IP42 (UL Type 1 Filtered, option +B054): option +E206	247
R11 IP22 (UL Type 1) and IP42 (UL Type 1 Filtered, option +B054)	248
R11: option +B055 (IP54 [UL Type 12])	249
R11 IP22 (UL Type 1) and IP42 (UL Type 1 Filtered, option +B054): options +C129, +H350, +H352	250
R11 option +B055 (IP54 [UL Type 12]): option +C128	251
R11 option +B055 (IP54 [UL Type 12]): option +C129	252
R11 option +B055 (IP54 [UL Type 12]): options +C129, +H350, +H352	253
R11 IP22 (UL Type 1) and IP42 (UL Type 1 Filtered, option +B054): option +D150	254
R11 IP22 (UL Type 1) and IP42 (UL Type 1 Filtered, option +B054): options +D150, +D151	255
R11 IP22 (UL Type 1) and IP42 (UL Type 1 Filtered, option +B054): option +E206	256
Location and size of power cable connection terminals	257
R8 input and motor cable terminal dimensions – bottom entry and exit	257

R8 input and motor cable terminal dimensions – top entry and exit	258
R8 input and motor cable terminals	259
R11 input and motor cable terminal dimensions – bottom entry and exit	260
R11 input and motor cable terminal dimensions – top entry and exit	261
R11 input cable terminals	262
R11 motor cable terminals	262
Terminals for connecting external resistors	262
Sine filter (+E206) cubicle, 400 mm: motor cable terminals	263
Sine filter (+E206) cubicle, 600 mm: motor cable terminals	263
Sine filter (+E206) cubicle, 1000 mm: motor cable terminals	264

## 15. The Safe torque off function

Contents of this chapter	265
Description	265
Compliance with the European Machinery Directive	266
Wiring	266
Activation switch	267
Cable types and lengths	267
Grounding of protective shields	267
Single drive (internal power supply)	268
Dual-channel connection	268
Single-channel connection	268
Multiple drives (internal power supply)	269
Multiple drives (external power supply)	270
Operation principle	270
Start-up including acceptance test	271
Competence	271
Acceptance test reports	271
Acceptance test procedure	271
Use	272
Maintenance	273
Competence	274
Fault tracing	274
Safety data	274
Abbreviations	275

## 16. Resistor braking

Contents of this chapter	277
Operation principle and hardware description	277
Selecting the default braking circuit components	277
Planning a braking system with the factory-installed brake chopper and custom brake resistors	278
Verifying the capacity of the braking equipment	278
Custom resistors	278
Calculating the allowed maximum braking power for a custom braking cycle	279
Selecting and routing the cables of a custom resistor	280
Minimizing electromagnetic interference	280
Maximum cable length	280
EMC compliance of the complete installation	280
Placing custom brake resistors	280
Protecting the system against thermal overload	280
Thermal protection of the resistors	281



Protecting the resistor cable against short-circuits .....	281
Mechanical installation of custom brake resistors .....	281
Electrical installation of custom brake resistors .....	281
Connection diagram .....	281
Connection procedure .....	282
Start-up .....	282
Technical data .....	283
Factory-installed brake chopper and resistor types .....	283
Ratings for the factory-installed brake choppers and resistors .....	283
Calculating the maximum braking power for a custom duty cycle .....	284
Ratings for factory-installed brake choppers and custom brake resistors .....	284
Terminals and cable entry data of factory-installed chopper/resistor cubicles .....	285

### ***Further information***



## 1

# Safety instructions

---



## Contents of this chapter

This chapter contains the safety instructions which you must obey when you install and operate the drive and do maintenance on the drive. If you ignore the safety instructions, injury, death or damage can occur.

## Use of warnings and notes

Warnings tell you about conditions which can cause injury or death, or damage to the equipment. They also tell you how to prevent the danger. Notes draw attention to a particular condition or fact, or give information on a subject.

The manual uses these warning symbols:



**Electricity warning** tells about hazards from electricity which can cause injury or death, or damage to the equipment.



**General warning** tells about conditions, other than those caused by electricity, which can cause injury or death, or damage to the equipment.



**Electrostatic sensitive devices warning** tells you about the risk of electrostatic discharge which can cause damage to the equipment.

---

## General safety in installation, start-up and maintenance

These instructions are for all personnel that install the drive and do maintenance work on it.



**WARNING!** Obey these instructions. If you ignore them, injury or death, or damage to the equipment can occur.

- Secure the cabinet to the floor to prevent it from toppling over when you pull out drive and LCL filter modules. The modules are heavy and have a high center of gravity.



- 
- Wear protective gloves and long sleeves. Some parts have sharp edges.
  - Beware of hot surfaces. Some parts, such as heatsinks of power semiconductors, remain hot for a while after disconnection of the electrical supply.
  - Beware of hot air exiting from the air outlets.
  - Keep the drive in its package or protect it otherwise from dust and metal shavings from drilling and grinding until you install it. Protect also the installed drive against dust and metal shavings. Electrically conductive debris inside the drive can cause damage or malfunction.
  - Vacuum clean the area below the drive before the start-up to prevent the drive cooling fan from drawing the dust inside the drive.
  - Do not cover the air inlet and outlet when the drive is running.
  - Make sure that there is sufficient cooling. See section [Examining the installation site](#) (page 67).
  - Keep the cabinet doors closed when the drive is powered. With the doors open, a risk of a potentially fatal electric shock, arc flash or high-energy arc blast exists. If you cannot avoid working on a powered drive, obey the local laws and regulations on live working (including – but not limited to – electric shock and arc protection).
  - Before you connect voltage to the drive, make sure that the cabinet doors are closed. Keep the doors closed during operation.
  - Before you adjust the drive operation limits, make sure that the motor and all driven equipment can operate throughout the set operation limits.
  - Before you activate the automatic fault reset or automatic restart functions of the drive control program, make sure that no dangerous situations can occur. These functions reset the drive automatically and continue operation after a fault or supply break. If these functions are activated, the installation must be clearly marked as defined in
-



IEC/EN 61800-5-1, subclause 6.5.3, for example, "THIS MACHINE STARTS AUTOMATICALLY".

- The maximum number of drive power-ups is five in ten minutes. Too frequent power-ups can damage the charging circuit of the DC capacitors.
- Make sure that any safety circuits (for example, emergency stop and Safe torque off) are validated at start-up. See chapter [The Safe torque off function](#) (page 265). For other safety functions, see their separate instructions.
- Handle the drive and LCL filter modules carefully:
  - Use safety shoes with a metal toe cap to avoid foot injury.
  - Lift the module with a lifting device only. Use the designated lifting points.
  - Frame R11:
    - Do not tilt the module. It is **heavy** and its **center of gravity is high**.
    - Make sure that the module does not topple over when you move it on the floor: Do not leave the module unattended on a sloping floor. Extend the support legs: Press each leg a little down and turn it aside. Whenever possible secure the module also with chains.

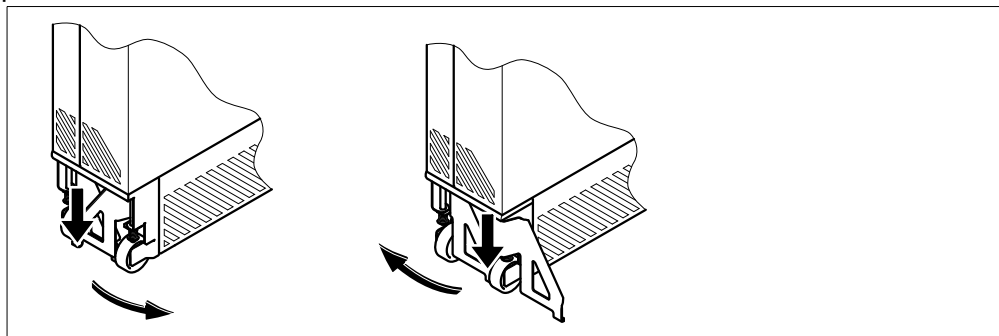

- Do not use the module installation ramp with plinth heights which exceed the maximum height marked on the ramp. (The maximum plinth height is 50 mm [1.97 in] when the telescopic ramp is fully retracted and 150 mm [5.91 in] when the ramp is fully extended.)
- Secure the module installation ramp carefully.

- To prevent the drive module from falling, attach its top lifting lugs with chains to the cabinet frame before you push the module into the cabinet and pull it from the cabinet. Work carefully preferably with help from another person. Keep a constant pressure with one foot on the base of the module to prevent the module from falling on its back.

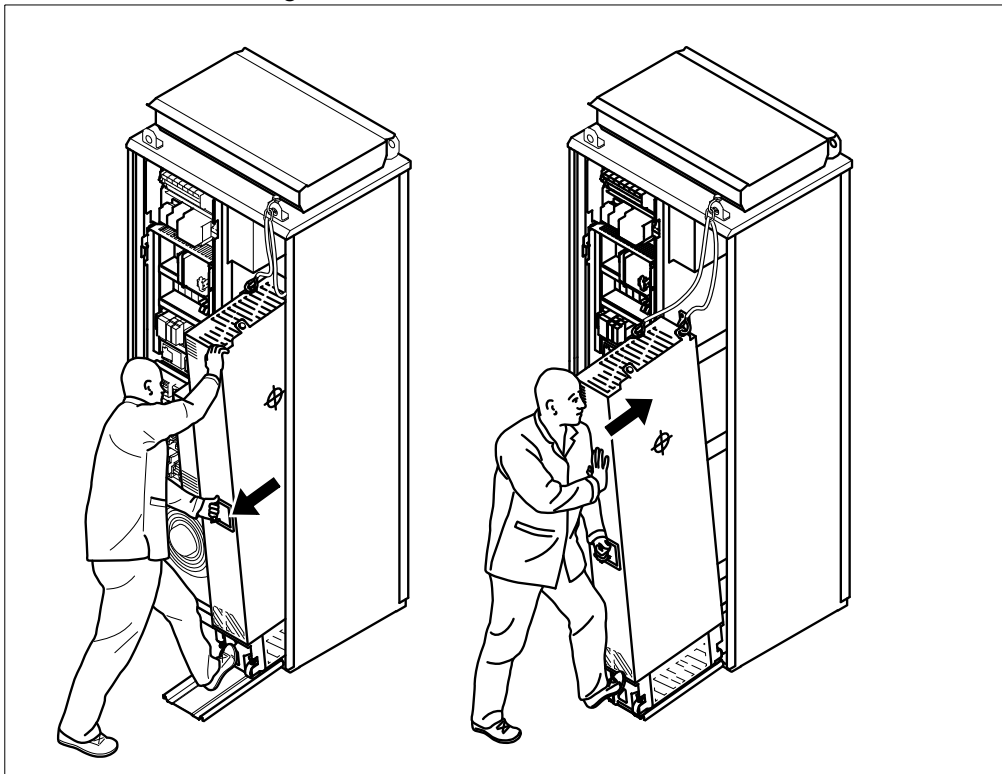

**Note:**

- If you select an external source for the start command and it is on, the drive will start immediately after fault reset unless you configure the drive for pulse start. See the firmware manual.
- When the control location is not set to Local, the stop key on the control panel will not stop the drive.
- Only authorized persons are allowed to repair a malfunctioning drive.



## Electrical safety in installation, start-up and maintenance

### ■ Electrical safety precautions

These warnings are for all personnel who do work on the drive, motor cable or motor.



**WARNING!** Obey these instructions. If you ignore them, injury or death, or damage to the equipment can occur. If you are not a qualified electrical professional, do not do installation or maintenance work. Go through these steps before you begin any installation or maintenance work.

1. Keep the cabinet doors closed when the drive is powered. With the doors open, a risk of electric shock and/or arcing exists.
2. Clearly identify the work location.
3. Disconnect all possible voltage sources.
  - Open the main disconnecting device (Q1) of the drive. Open the disconnecter of the supply transformer as the main disconnecting device of the drive does not remove the voltage from the input busbars or V-meter (option +G334) of the drive.
  - Make sure that reconnection is not possible. Lock the disconnectors to open position and attach a warning notice to them.
  - Disconnect any external power sources from the control circuits before you do work on the control cables.
  - After you disconnect the drive, always wait for 5 minutes to let the intermediate circuit capacitors discharge before you continue.
4. Protect any other energized parts in the work location against contact.
5. Take special precautions when close to bare conductors.



6. Measure that the installation is de-energized.



**WARNING!** If the measurement requires removal or disassembly of shrouding or other cabinet structures, obey the local laws and regulations applicable to live working (including – but not limited to – electric shock and arc protection).

- Use a multimeter with an impedance of at least 1 Mohm.
- Make sure that the voltage between the drive input power terminals (L1, L2, L3) and the grounding (PE) busbar is close to 0 V. The measuring holes in the shroud of the standard drive are shown below.

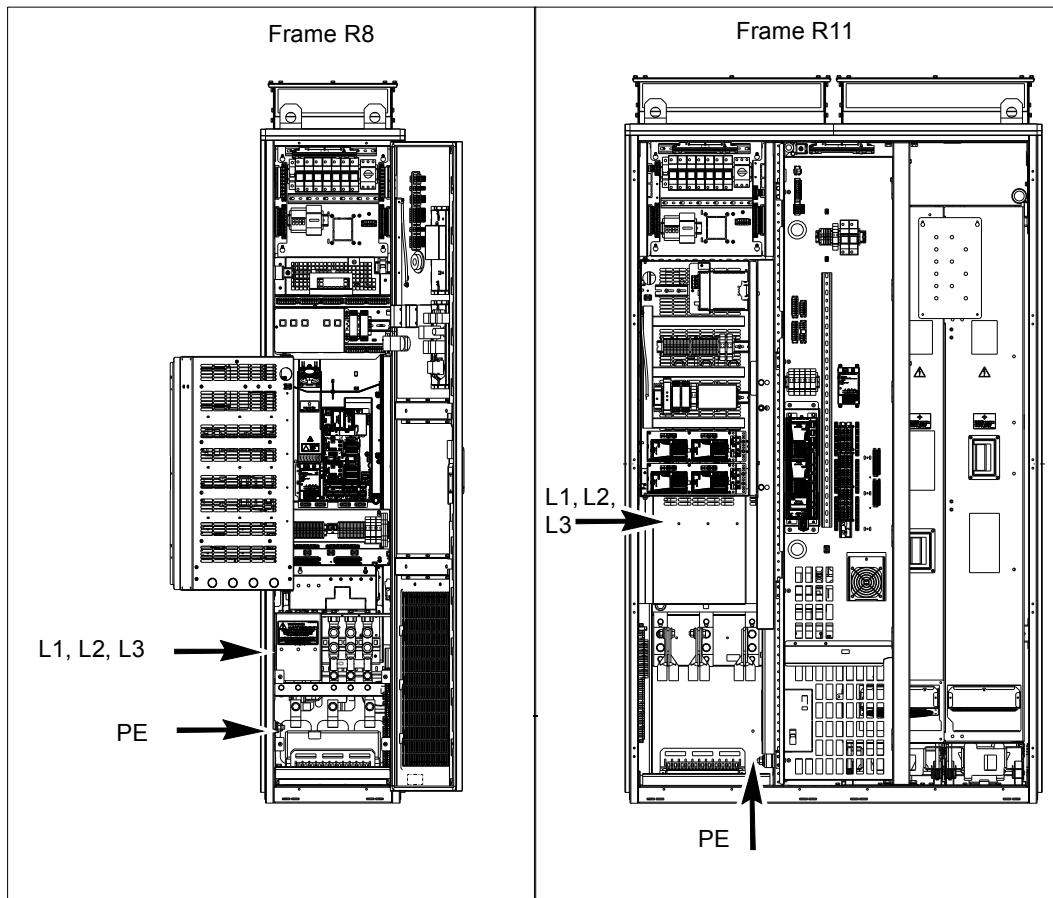

- Frame R11: Make sure that the voltage of the drive AC busbars between the drive module and the LCL filter and the grounding (PE) busbar are close to 0 V. The measuring holes in the shroud of the standard drive are shown below.

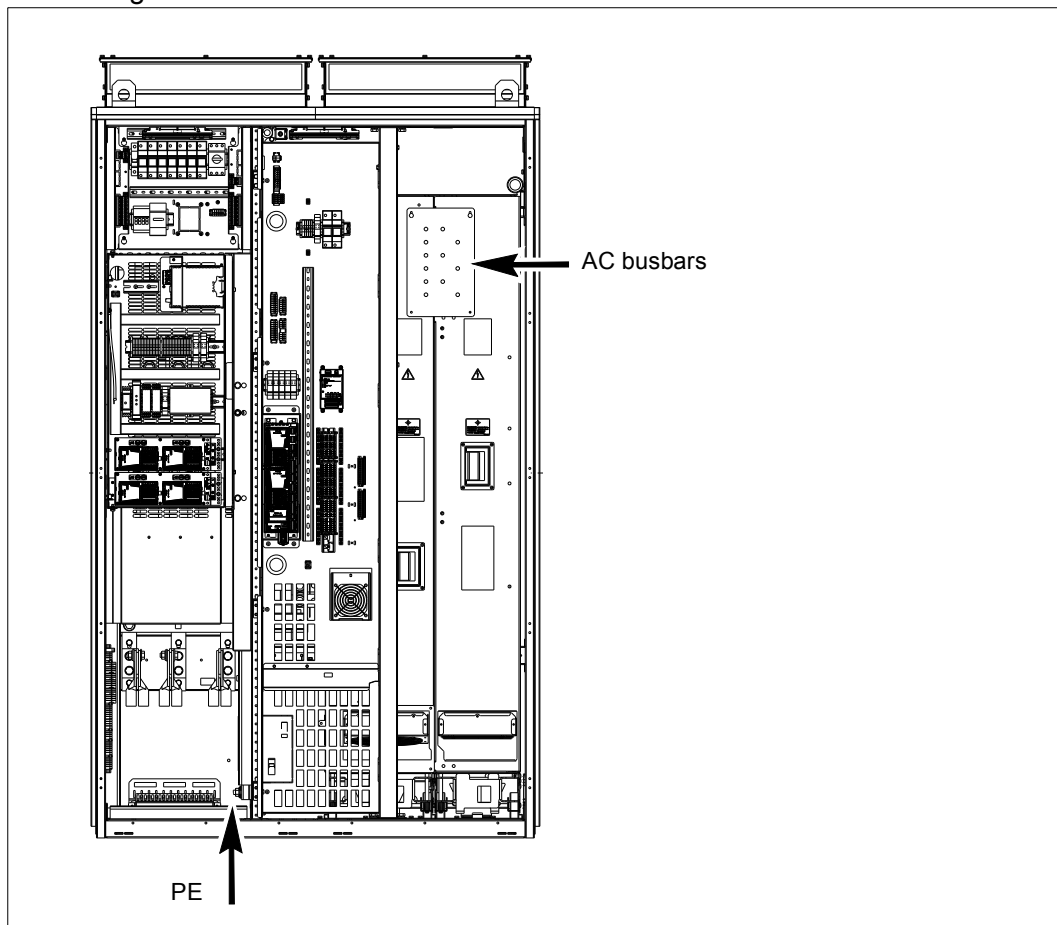

22 Safety instructions

- Make sure that the voltage between the DC busbars is close to 0 V. You can measure the voltage through the holes in the shroud.

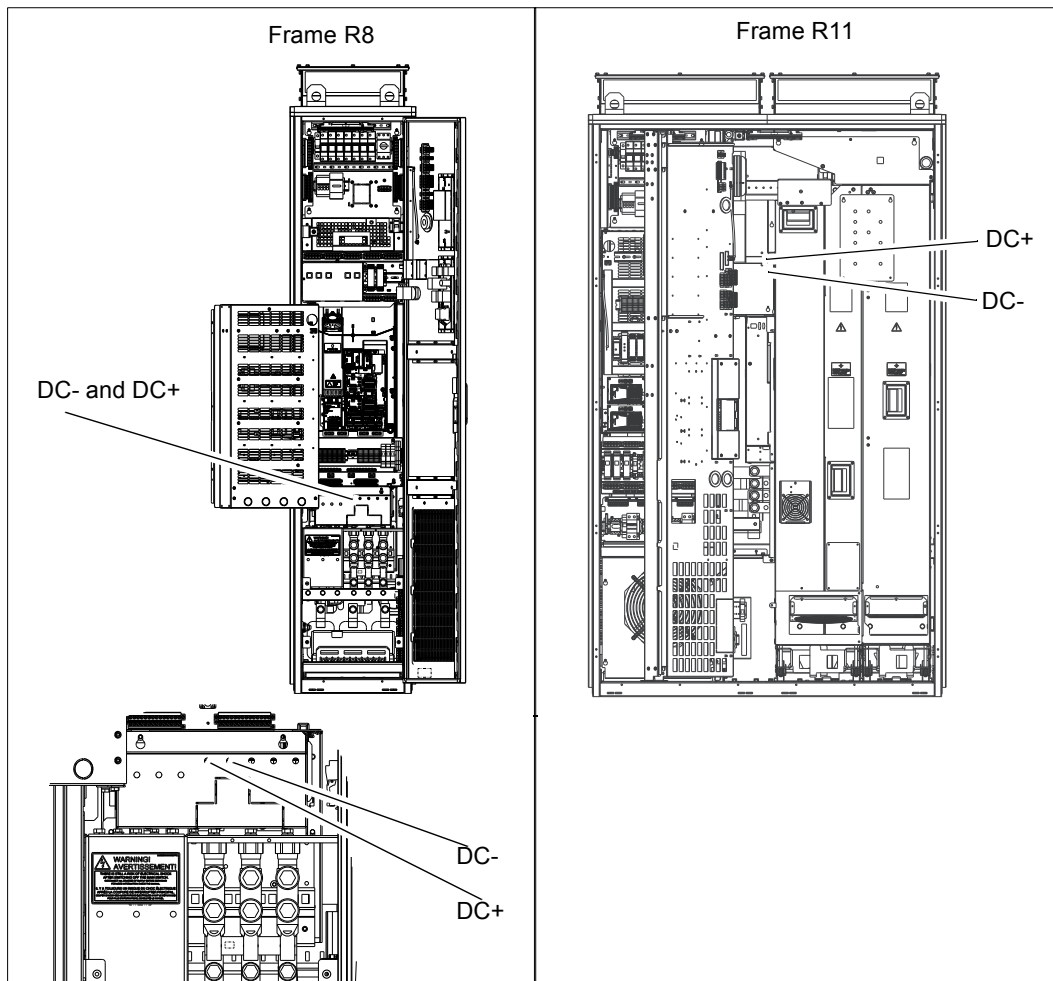

- For frame R8, you can measure the voltage at the drive module input (a) and output (b) terminals through the holes in the shroud.

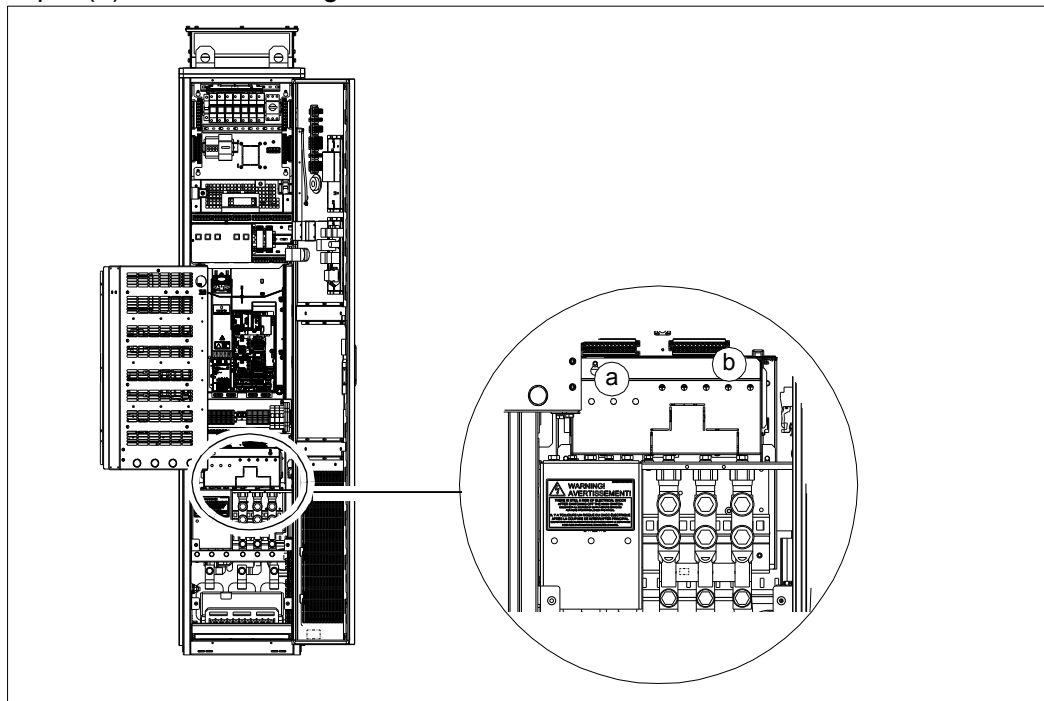

7. Install temporary grounding as required by the local regulations. Connect the AC and DC busbars to PE with a temporary grounding tool.
8. Ask the person in control of the electrical installation work for a permit to work.

### ■ Additional instructions and notes



**WARNING!** Obey these instructions. If you ignore them, injury or death, or damage to the equipment can occur.

- If you are not a qualified electrical professional, do not do electrical installation or maintenance work.
- Do not install a drive with an EMC filter (option +E202) on an IT (ungrounded) power system or a high resistance-grounded (over 30 ohms) power system without disconnecting the filter and/or the varistor screws.
- Do not connect the drive to a voltage higher than what is specified on the type designation label. If you do, the brake chopper (option +D150) starts to operate which causes overheating of the brake resistor (option +D151, if present). Overvoltage can also cause the motor to rush to its maximum speed.
- We do not recommend that you secure the cabinet by arc welding. If you have to, obey the instructions on page 80.
- Do not do insulation or voltage withstand tests on the drive or its modules.

#### Note:

- The motor cable terminals of the drive are at a dangerous voltage when the input power is on, regardless of whether the motor is running or not.
- The DC bus, brake chopper and brake resistors (if any) are at a dangerous voltage.
- External wiring can supply dangerous voltages to the relay outputs of the control units of the drive.



- The Safe torque off function does not remove the voltage from the main and auxiliary circuits. The function is not effective against deliberate sabotage or misuse.



**WARNING!** Use a grounding wrist band when you handle the printed circuit boards. Do not touch the boards unnecessarily. The boards contain components sensitive to electrostatic discharge.

---



**WARNING!** Obey these instructions. If you ignore them, equipment malfunction and damage to the fiber optic cables can occur.

- Handle fiber optic cables with care.
- When you unplug the cables, always hold the connector, not the cable itself.
- Do not touch the ends of the fibers with bare hands as the ends are extremely sensitive to dirt.
- Do not bend the fiber optic cables too tightly. The minimum allowed bend radius is 35 mm (1.4”).

---

### Additional instruction for DC connection

---



**WARNING!** Do not connect the drive DC link to a common DC system. The drive will get damaged.

---

### Grounding

These instructions are for all personnel who are responsible for the grounding of the drive.

---



**WARNING!** Obey these instructions. If you ignore them, injury or death, or equipment malfunction can occur, and electromagnetic interference can increase.

- If you are not a qualified electrical professional, do not do grounding work.
  - Always ground the drive, the motor and adjoining equipment. This is necessary for the personnel safety. Proper grounding also reduces electromagnetic emission and interference.
  - Make sure that the conductivity of the grounding conductors is sufficient. See section [Selecting the power cables](#) (page 90). Obey the local regulations.
  - Connect the power cable shields to protective earth (PE) of the drive to make sure of personnel safety.
  - Make a 360° grounding of the power and control cable shields at the cable entries to suppress electromagnetic disturbances.
  - In a multiple-drive installation, connect each drive separately to the protective earth (PE) busbar of the switch board or the transformer.
-



**Note:**

- You can use power cable shields as grounding conductors only when their conductivity is sufficient.
- As the normal touch current of the drive is higher than 3.5 mA AC or 10 mA DC, you must use a fixed protective earth (PE) connection. See standard EN 61800-5-1, 4.3.5.5.2.



## Additional instructions for permanent magnet motor drives

### ■ Safety in installation, start-up and maintenance

These are additional warnings concerning permanent magnet motor drives. The other safety instructions in this chapter are also valid.



**WARNING!** Obey these instructions. If you ignore them, injury or death and damage to the equipment can occur.

- Do not do work on the drive when the permanent magnet motor is rotating. A rotating permanent magnet motor energizes the drive including its input power terminals.

Before installation, start-up and maintenance work on the drive:

- Stop the motor.
  - Disconnect the motor from the drive with a safety switch or by other means.
  - If you cannot disconnect the motor, make sure that the motor cannot rotate during work. Make sure that no other system, like hydraulic crawling drives, can rotate the motor directly or through any mechanical connection like felt, nip, rope, etc.
  - Measure that the installation is de-energized.
    - Use a multimeter with an impedance of at least 1 Mohm.
    - Make sure that the voltage between the drive output terminals (U2, V2, W2) and the grounding (PE) busbar is close to 0 V.
    - Make sure that the voltage between the drive input power terminals (L1, L2, L3) and the grounding (PE) busbar is close to 0 V.
    - Make sure that the voltage between the plus and minus busbars of the drive DC link and the grounding (PE) busbar is close to 0 V.
  - Install temporary grounding to the drive output terminals (U2, V2, W2). Connect the output terminals together as well as to the PE.
  - Make sure that the operator cannot run the motor over the rated speed. Motor overspeed causes overvoltage which can damage the capacitors in the intermediate circuit of the drive.
- 



# 2

## Introduction to the manual

---

### Contents of this chapter

This chapter describes the manual. It contains a flowchart of steps in checking the delivery, installing and starting up the drive. The flowchart refers to chapters/sections in this manual and to other manuals.

### Target audience

This manual is intended for people who plan the installation, install, start up, use and service the drive. Read the manual before working on the drive. You are expected to know the fundamentals of electricity, wiring, electrical components and electrical schematic symbols.

The manual is written for readers worldwide. Both SI and imperial units are shown.

### Contents of the manual

This manual contains the instructions and information for the basic drive configuration. The chapters of the manual are briefly described below.

[Safety instructions](#) gives safety instructions for the installation, start-up, operation and maintenance of the drive.

[Introduction to the manual](#) gives an introduction to this manual.

[Operation principle and hardware description](#) describes the operation principle and construction of the drive.

[Mechanical installation](#) describes how to install the drive mechanically.

[Guidelines for planning the electrical installation](#) contains instructions for the motor and cable selection, protections and cable routing.

---

**Electrical installation** gives instructions on wiring the drive.

**Control unit of frame R11** contains the default I/O connection diagrams, descriptions of the terminals and technical data for the control unit of the drive.

**Installation checklist** contains a list for checking the mechanical and electrical installation of the drive.

**Start-up** describes the start-up procedure of the drive.

**Fault tracing** describes the fault tracing possibilities of the drive.

**Maintenance** contains preventive maintenance instructions.

**Technical data** contains the technical specifications of the drive, for example, the ratings, sizes and technical requirements, provisions for fulfilling the requirements for CE and other markings.

**Dimensions** contains example dimension drawings of the drive.

**The Safe torque off function** describes the Safe torque off function of the drive and gives instructions on its implementation.

**Resistor braking** describes selection, protection, wiring and start-up of optional brake choppers (+D150) and resistors (+D151). The chapter also contains technical data.

## Related documents

Drive hardware manuals and guides	Code (English)
<i>Drive/converter/inverter safety instructions</i>	Multilingual code: 3AXD50000037978
<i>ACS880-37 drives (45...400 kW) hardware manual</i>	3AXD50000035159
<i>ACx-AP-x assistant control panels user's manual</i>	3AUA0000085685
<i>ACS880 frames R1 to R11 EMC filter and ground-to-phase varistor disconnecting instructions</i>	3AUA0000125152
<b>Drive firmware manuals and guides</b>	
<i>ACS880 primary control program firmware manual</i>	3AUA0000085967
<i>Quick start-up guide for ACS880 drives with primary control program</i>	3AUA0000098062
<i>ACS880 IGBT supply control program firmware manual</i>	3AUA0000131562
<b>Option manuals and guides</b>	
<i>Drive composer start-up and maintenance PC tool user's manual</i>	3AUA0000094606
<i>Bypass connection for ACS880-07, -17, -37 (40...1200 A) option description</i>	3AXD50000048959
<i>FSO-12 safety functions module user's manual</i>	3AXD50000015612
<i>FSO-21 safety functions module user's manual</i>	3AXD50000015614
<i>User's manual for Prevention of unexpected start-up (+Q950) for ACS880-07/17/37 drives</i>	3AUA0000145922
<i>User's manual for Emergency stop, stop category 0 (+Q951) for ACS880-07/17/37 drives</i>	3AUA0000119895
<i>User's manual for Emergency stop, stop category 1 (+Q952) for ACS880-07/17/37 drives</i>	3AUA0000119896
<i>User's manual for Prevention of unexpected start-up (+Q957) for ACS880-07/17/37 drives</i>	3AUA0000119910
<i>User's manual for Emergency stop, stop category 0 (+Q963) for ACS880-07/17/37 drives</i>	3AUA0000119908
<i>User's manual for Emergency stop, stop category 1 (+Q964) for ACS880-07/17/37 drives</i>	3AUA0000119909
<i>User's manual for Emergency stop, configurable stop category 0 or 1 (+Q978) for ACS880-07/17/37 drives</i>	3AUA0000145920

Manuals and quick guides for I/O extension modules, fieldbus adapter, etc.	
--	--

You can find manuals and other product documents in PDF format on the Internet. See section *Document library on the Internet* on the inside of the back cover. For manuals not available in the Document library, contact your local ABB representative. The code below opens an online listing of the manuals applicable to the product:



ACS880-37 (45...400 kW, 60...450 hp) manuals

## Categorization by frame size and option code

Some instructions, technical data and dimension drawings which concern only certain frame sizes are marked with the symbol of the frame size, for example R11. The frame size is marked on the type designation label (see page 62).

The instructions, technical data and dimension drawings which only concern certain optional selections are marked with option codes (such as +E205). The options included in the drive can be identified from the option codes visible on the type designation label (see page 62). The option selections are listed in section *Type designation key* (page 63).

---

## Quick installation, commissioning and operation flowchart

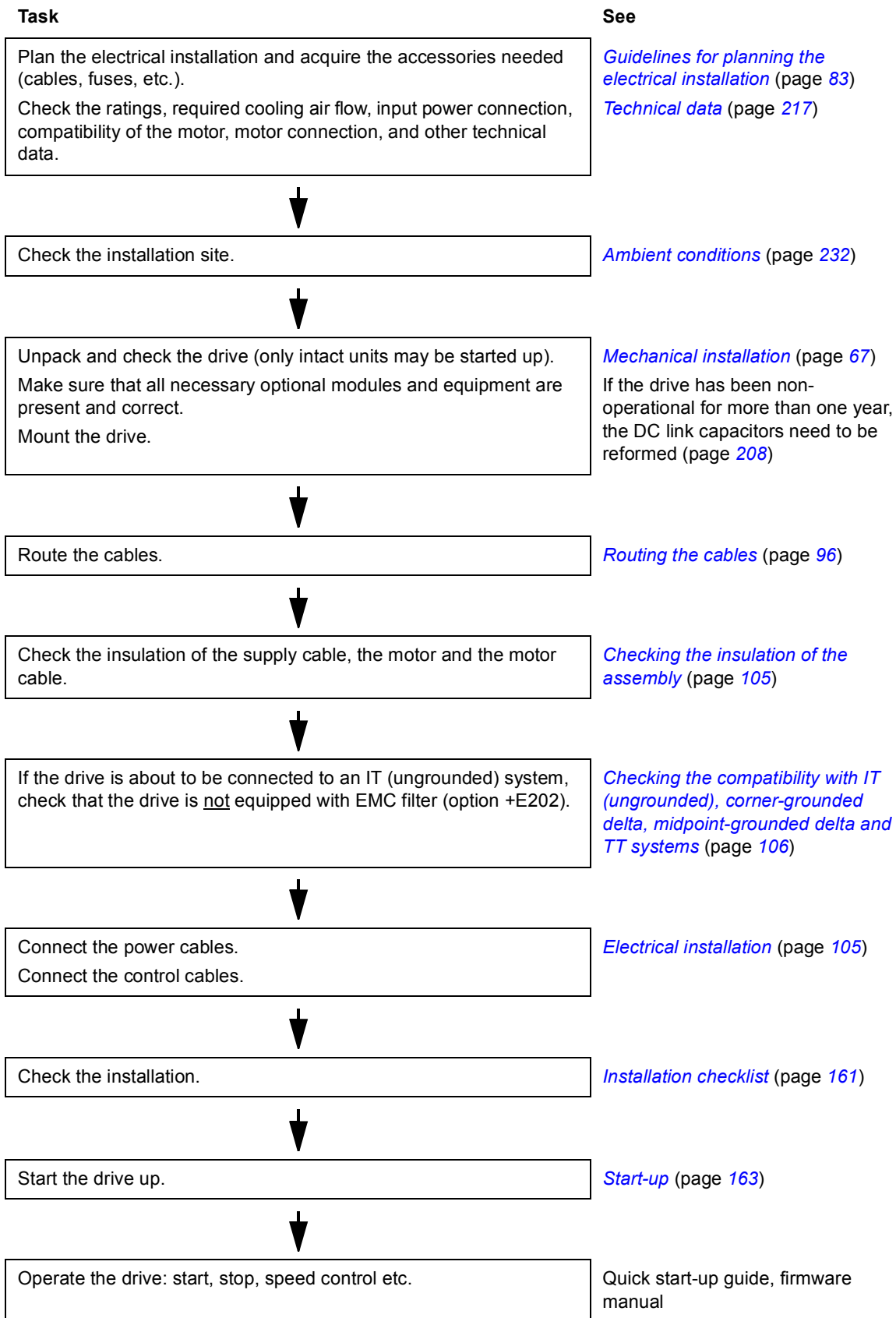

## Terms and abbreviations

Term/ Abbreviation	Description
ACx-AP-x	Assistant control panel, advanced operator keypad for communication with the drive.
Brake chopper	Optional brake chopper (option +D150) conducts the surplus energy from the intermediate DC circuit of the drive to the brake resistor when necessary. The chopper operates when the DC link voltage exceeds a certain maximum limit. The voltage rise is typically caused by deceleration (braking) of a high inertia motor.
Brake resistor	Optional brake resistor (option +D151) dissipates the drive surplus braking energy conducted by the brake chopper to heat.
Control unit, control board	The drive with frame R11 contains two ZCU control units. One controls the line-side converter, the other the motor-side converter. The drive with frame R8 has only one motor-side ZCU control unit. Control board QCON-21 controls the line-side converter. As standard, the external I/O control signals are connected to the control unit, or optional I/O extensions mounted on it.
Drive	Frequency converter for controlling AC motors. The drive consists of the <i>line-side converter</i> and <i>motor-side converter</i> connected together by the DC link. In this manual, the term refers to the ACS880-37 as a whole.
Drive control unit	The control unit which controls the drive through the motor-side converter. The user control interface to the drive. In this manual, the term refers to the motor-side converter control unit of the drive
EMC	Electromagnetic compatibility
EMI	Electromagnetic interference
EMT	Electrical metallic tubing
FAIO-01	Optional analog I/O extension module
FCAN-01	Optional FCAN-01 CANopen adapter module
FCNA-01	Optional ControlNet™ adapter module
FDCO-01	Optional DDCS communication module with two pairs of 10 Mbit/s DDCS channels
FDNA-01	Optional DeviceNet™ adapter module
FECA-01	Optional EtherCAT adapter module
FEN-01	Optional TTL incremental encoder interface module
FEN-11	Optional TTL absolute encoder interface module
FEN-21	Optional resolver interface module
FEN-31	Optional HTL incremental encoder interface module
FENA-11	Optional Ethernet adapter module for EtherNet/IP™, Modbus TCP and PROFINET IO protocols
FENA-21	Optional Ethernet adapter module for EtherNet/IP™, Modbus TCP and PROFINET IO protocols, 2-port
FEPL-01	Optional Ethernet POWERLINK adapter module
FIO-01	Optional digital I/O extension module
FIO-11	Optional analog I/O extension module
FPBA-01	Optional PROFIBUS DP adapter module
Frame (size)	Relates to the construction type of the component in question. For example, several drive types with different power ratings may have the same basic construction, and a frame size is used in reference to all those drive types. To determine the frame size of a drive type, see the rating tables in chapter <i>Technical data</i> .
FSO-12, FSO-21	Optional functional safety module
IGBT	Insulated gate bipolar transistor; a voltage-controlled semiconductor type widely used in drives due to their easy controllability and high switching frequency.

Term/ Abbreviation	Description
Line-side converter	The part of the <i>drive</i> that converts AC to DC for the motor. Includes an LCL filter.
Motor-side converter	The part of the <i>drive</i> that converts DC to AC for the motor. The motor-side converter is also capable of feeding energy from a decelerating motor into the DC link.
I/O	Input/Output
QCON-21	Control board that controls the line-side converter of frame R8.
RFI	Radio-frequency interference
STO	Safe torque off. See chapter <i>The Safe torque off function</i> (page 265).
ZCU	Control unit type. The drive with frame R11 contains two ZCU control units. One controls the line-side converter, the other the motor-side converter. The drive with frame R8 has only one motor-side ZCU control unit. See also descriptions <i>Control unit</i> , <i>control board</i> and <i>Drive control unit</i> above.
ZMU	The memory unit attached to the control unit of the drive





# 3

## Operation principle and hardware description

---

### Contents of this chapter

This chapter briefly describes the operation principle and construction of the drive.

### Operation principle

The ACS880-37 is a low-harmonic, air-cooled, cabinet-installed drive for controlling asynchronous AC induction motors, permanent magnet synchronous motors, AC induction servomotors and ABB synchronous reluctance (SynRM) motors.

---

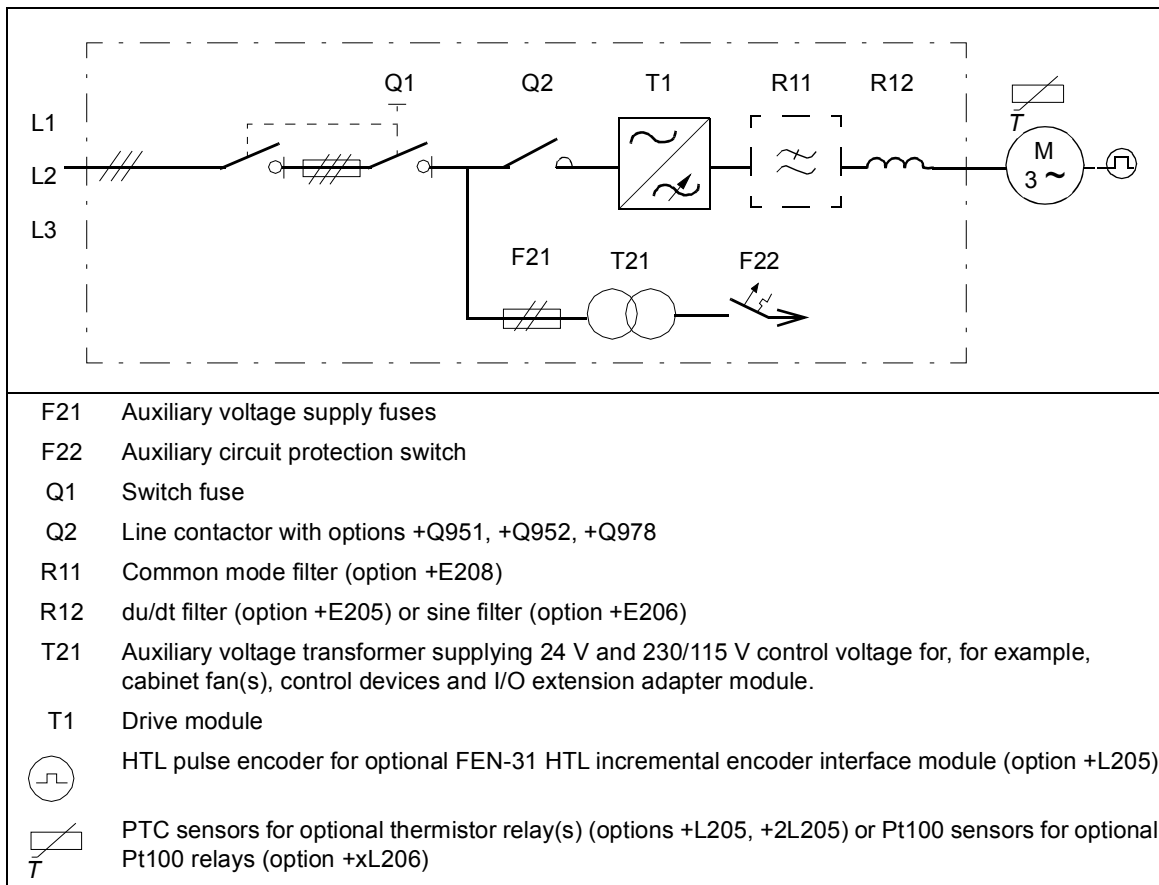

■ Single-line circuit diagram of the drive

Single-line diagram of R8

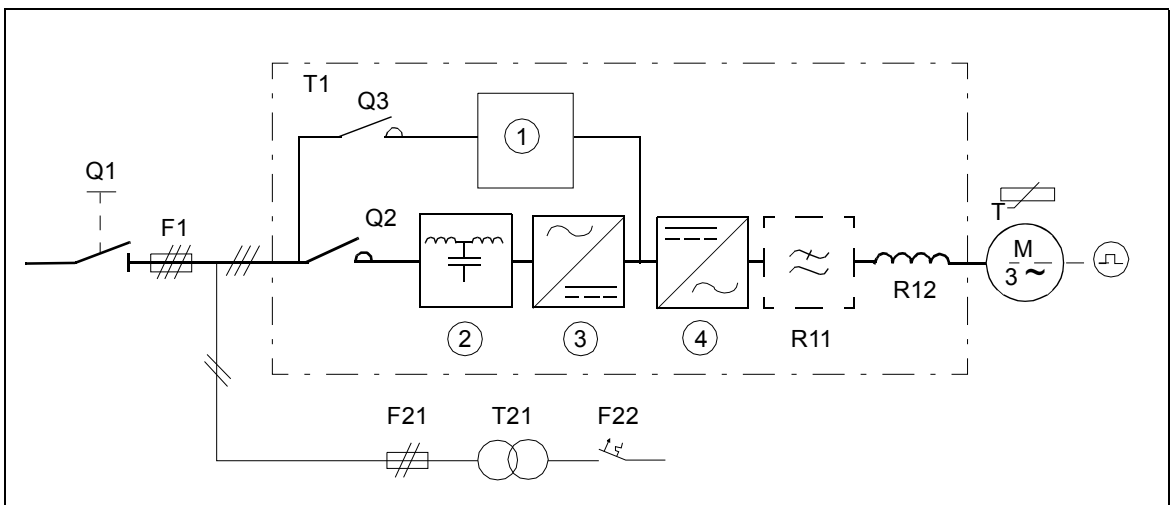

### Single-line diagram of R11



- Q1 Main switch-disconnector (switch-disconnector and separate fuses)
- F1 AC fuses
- F21 Auxiliary voltage supply fuses
- F22 Auxiliary circuit protection switch
- Q2 Line contactor inside the drive module. Q2 is controlled by the line-side converter control unit. If Start (Running) command is given to the drive, Q2 is closed and the line-side converter starts to modulate.
- Q3 Charging circuit contactor (with options +Q951, +Q952, +Q978) or switch (as standard)
- R11 Optional common mode filter (option +E208)
- R12 Optional du/dt filter (option +E205) or sine filter (option +E206)
- T1 Drive module. Contains drive module (line-side converter + motor-side converter), LCL filter and line contactor.
- T21 Auxiliary voltage transformer supplying 24 V and 230/115 V control voltage for, for example, cabinet fan(s), control devices and I/O extension adapter module.
- 1 Charging circuit
- 2 LCL filter
- 3 Line-side converter
- 4 Motor-side converter
-  Pulse encoder for FEN-31 HTL incremental encoder interface module (option +L502)
-  Motor temperature sensor

■ of the drive with brake options +D150 and +D151

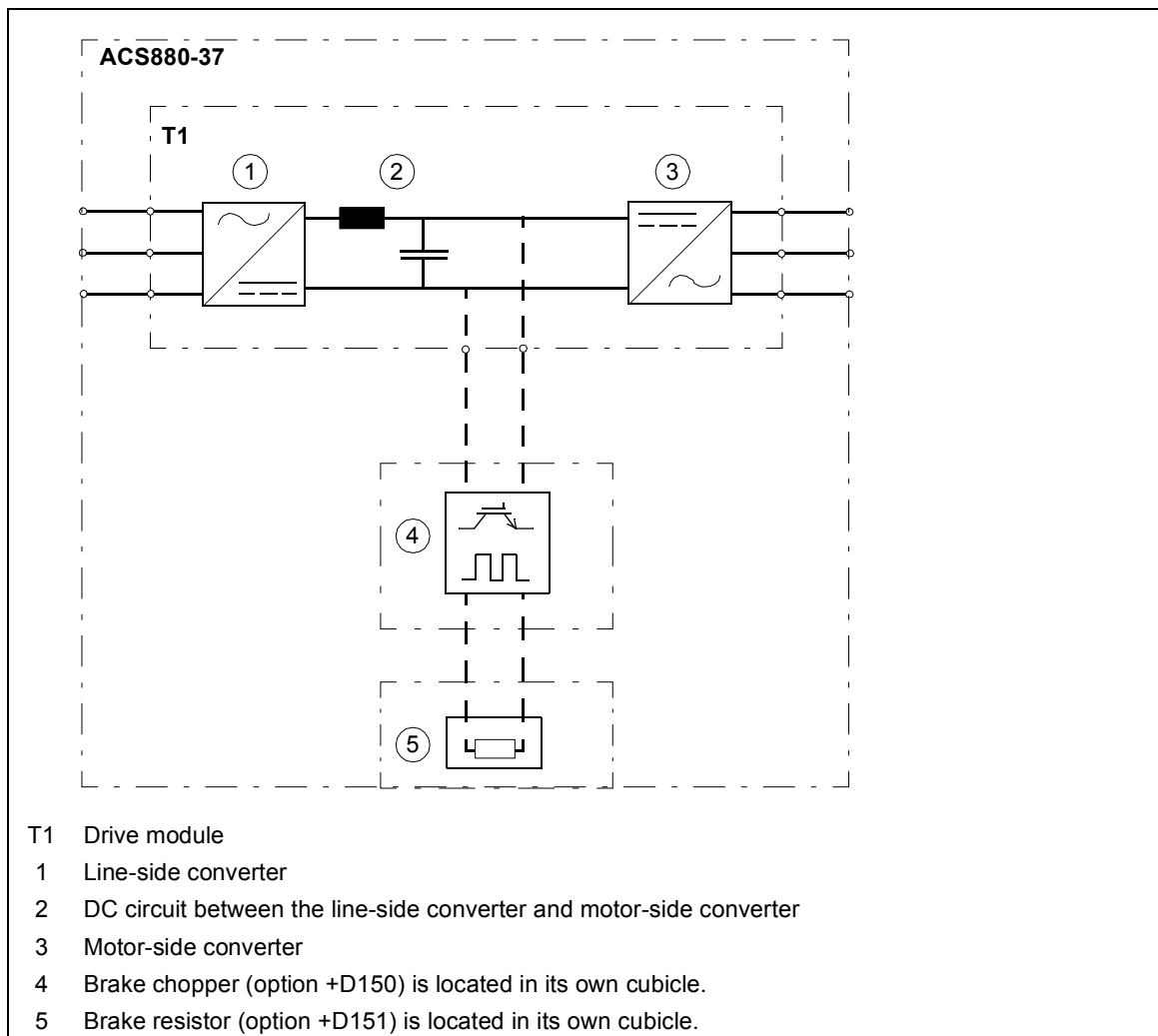

## ■ Line-side converter

The line-side converter rectifies three-phase AC current to direct current for the intermediate DC link of the drive.

The following diagram shows the simplified main circuit of the line-side converter. In R11, a ZCU control unit controls the line-side converter. See [Overview of power and control connections](#). In R8, a QCON-21 control board controls the line-side converter.

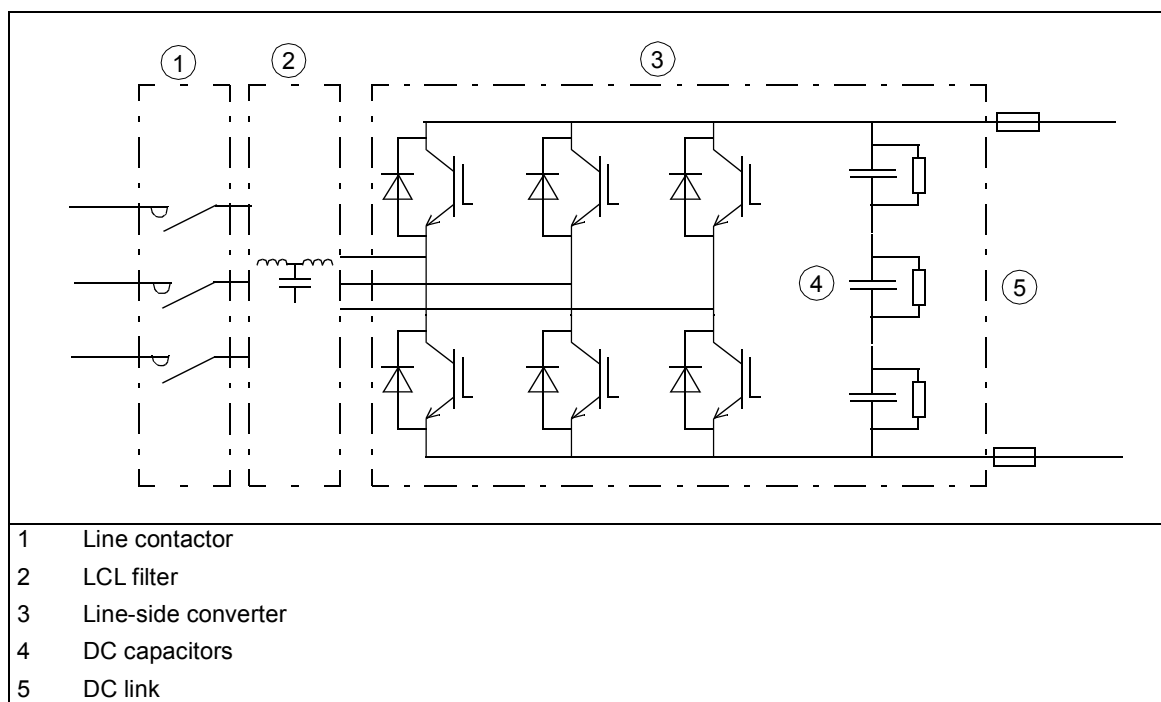

### AC voltage and current waveforms

The AC current is sinusoidal at a unity power factor. The LCL filter suppresses the AC voltage distortion and current harmonics. The high AC inductance smooths the line voltage waveform distorted by the high-frequency switching of the converter. The capacitive component of the filter effectively filters the high-frequency (over 1 kHz) harmonics.

### Charging

Charging is needed to power up the DC link capacitors smoothly. Discharged capacitors cannot be connected to the full supply voltage. The voltage must be increased gradually until the capacitors are charged and ready for normal use. The drive contains a resistive charging circuit consisting of contactor and charging resistors. The charging circuit is in use after start-up until the DC voltage has risen to a predefined level.

## ■ Motor-side converter

The motor-side converter converts the DC back to AC that rotates the motor. It is also able to feed the braking energy from a rotating motor back into the DC link. A ZCU control unit controls the motor-side converter.

The control unit also controls the drive through the motor-side converter. In this manual, the term drive control unit refers to the motor-side converter control unit. For the location of the drive control unit, see [Cabinet layout](#) figures and [Overview of power and control connections](#).

## ■ Cabinet layout

The layout drawings give an example of the R8 and R11 cabinets. The contents of the cabinet depend on the ordered options. For example:

- In the lower power R8 and R11 cabinets with only a few options the “door fan” is replaced with a shroud (basic cabinet without 24 V auxiliary voltage supply, option +E205 du/dt filter and +E208 common mode filter).
- In R8 cabinets, the swing-out frame and mounting plate above the “door fan” can be replaced with shrouds.
- In R11 cabinets, the swing-out frame and two mounting plates above the “door fan” can be replaced with shrouds.

### Cabinet layout of R8

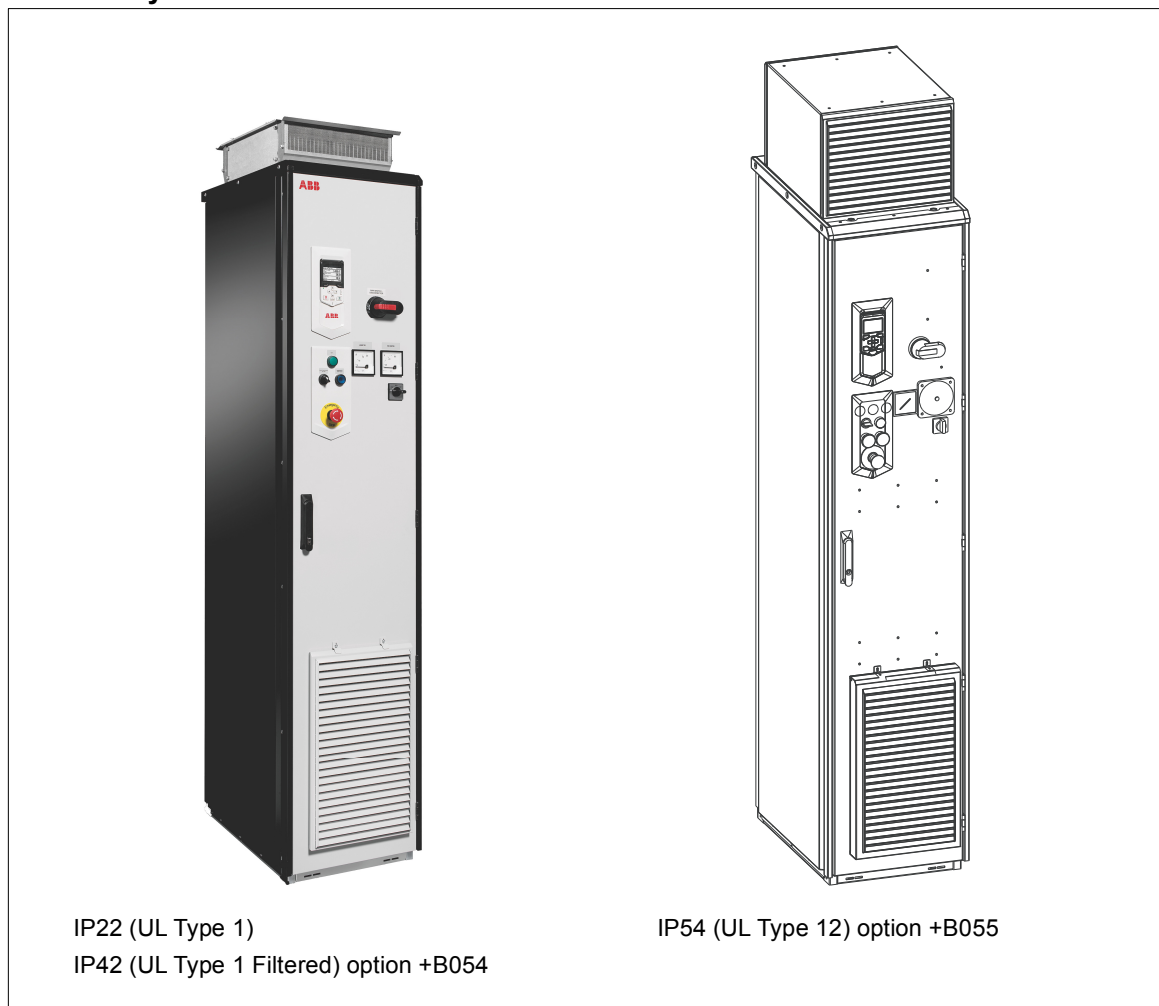

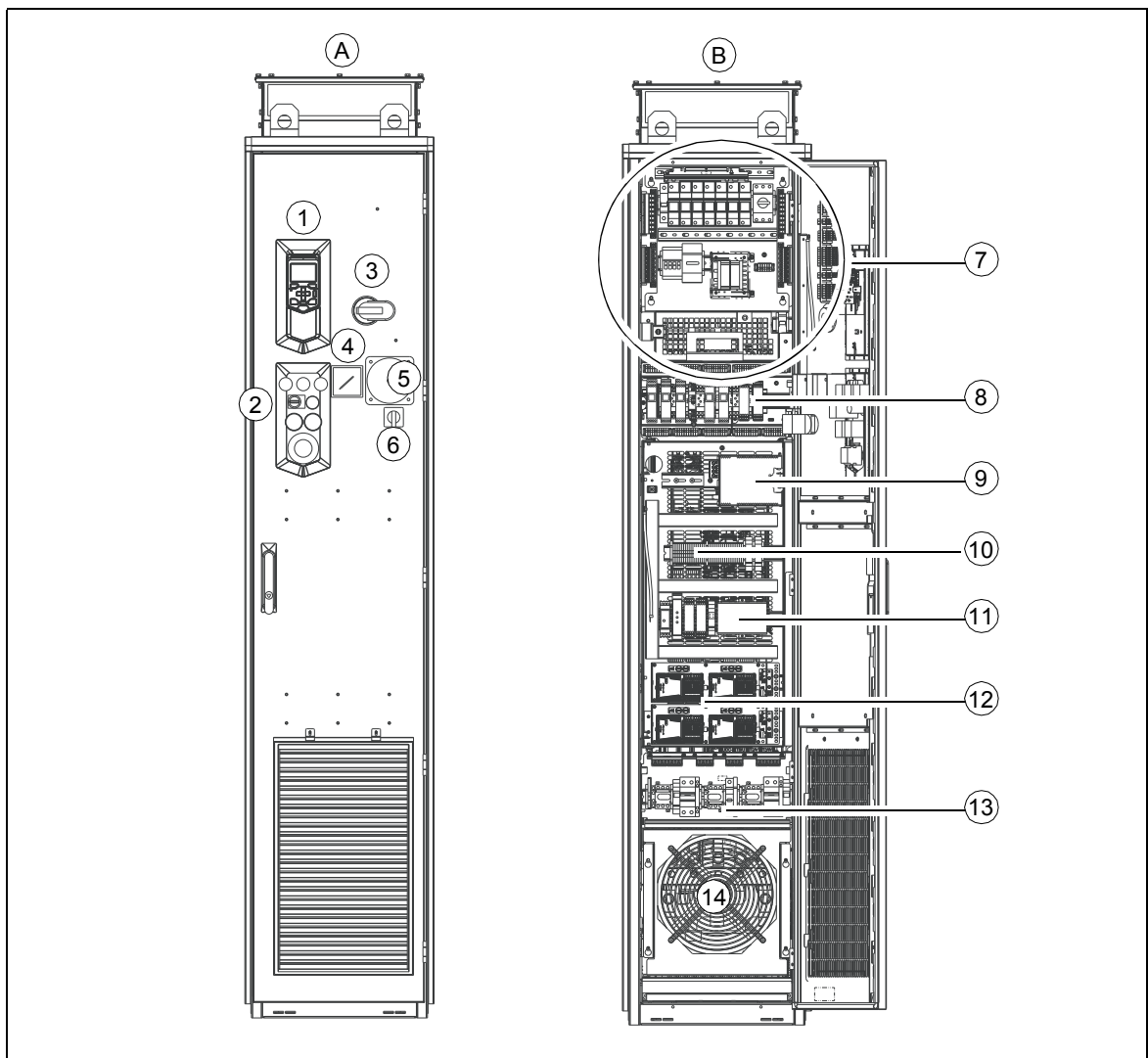

- A Drive module cubicle, door closed
- B Drive module cubicle, door open
- 1 Drive control panel (see page 53)
- 2 Operating buttons and door lights (see page 52)
- 3 Main switch handle
- 4 Indicators, for example, V-meter and A-meter
- 5 UL Type V-meter
- 6 V-meter switch
- 7 Main fuses for control devices, IP54 fan with option +B055, transformer with option +B055, V-meter (option +G334), starter for auxiliary motor fan (option +M600)
- 8 Thermistor and PT100 relays (options +L505, +L506)
- 9 Buffering module and power supply unit
- 10 Terminal blocks X18 and X19
- 11 Ground fault monitoring and safety circuit component
- 12 Optional extension adapters and modules
- 13 Components and connection terminals for options +G300, +G301, +G307, +G313
- 14 "Door fan"

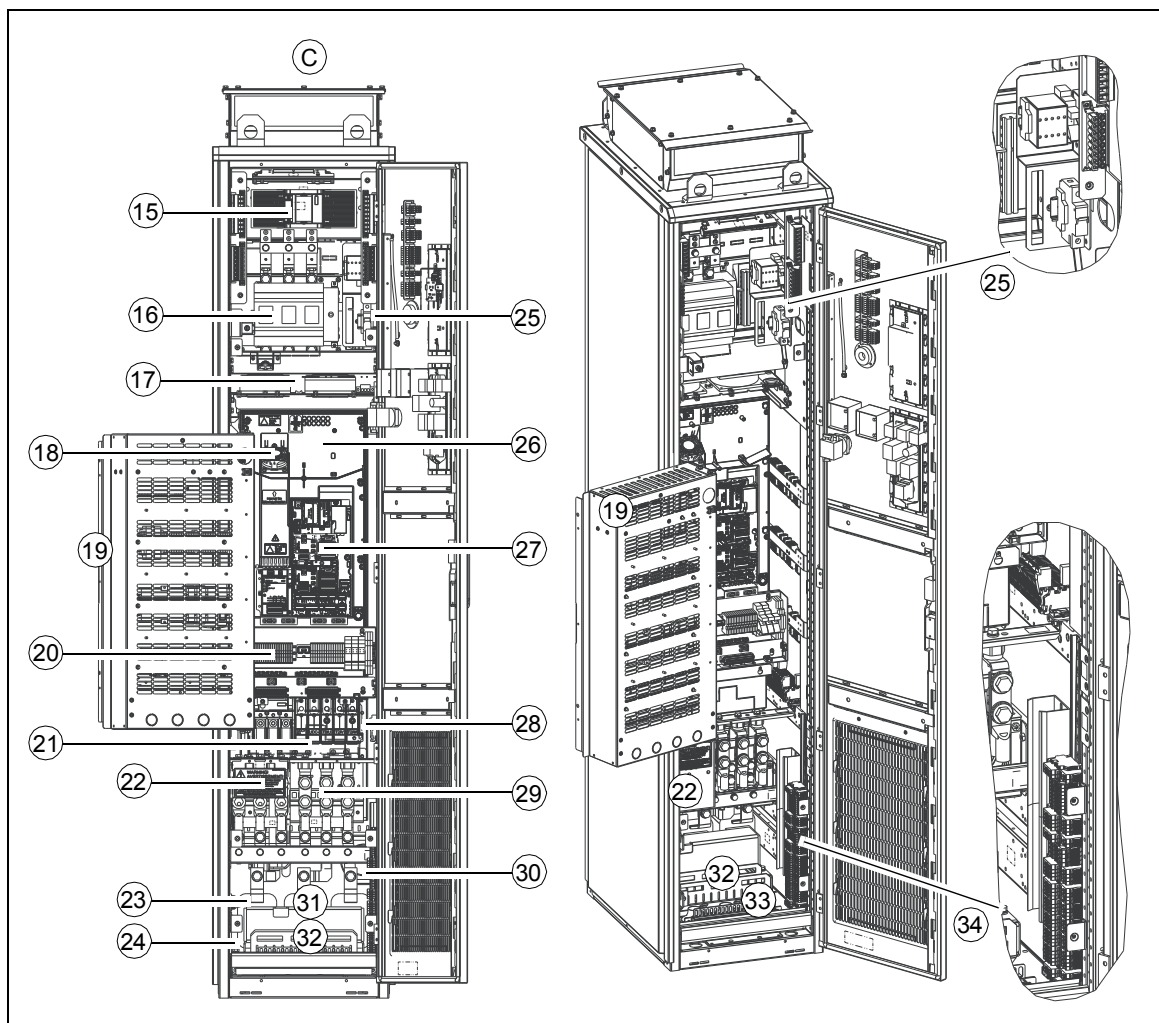

- |    |  |
|----|--|
| C  | Swing-out frame open   |
| 15 | Main contactor   |
| 16 | Switch fuse (Q1)   |
| 17 | Internal cabinet fans  |
| 18 | Auxiliary cooling fan  |
| 19 | Swing-out frame  |
| 20 | Terminal block (X504, option +L504) for external control cable connections to the control unit |
| 21 | Module cooling fan   |
| 22 | Input cable connection terminals behind the shroud (bottom entry)                              |
| 23 | PE busbar  |
| 24 | Cabinet heater (option +G300)  |
| 25 | Auxiliary voltage transformer (T21) and distribution components                                |
| 26 | Drive module   |
| 27 | Control unit (see page 151)  |
| 28 | X8X9 terminal block  |
| 29 | Motor cable connection terminals (bottom entry)  |
| 30 | Common mode filter (option +E208)  |
| 31 | $du/dt$ filter (option +E205)  |
| 32 | Power cable entry  |
| 33 | Control cable entry  |
| 34 | X250 terminal block  |



### Cabinet layout of R11



IP22 (UL Type 1)  
IP42 (UL Type 1 Filtered) option +B054

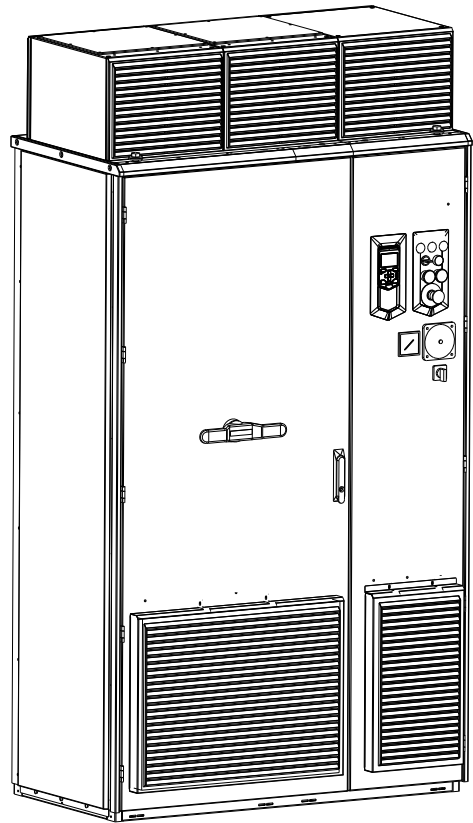

IP54 (UL Type 12) option +B055

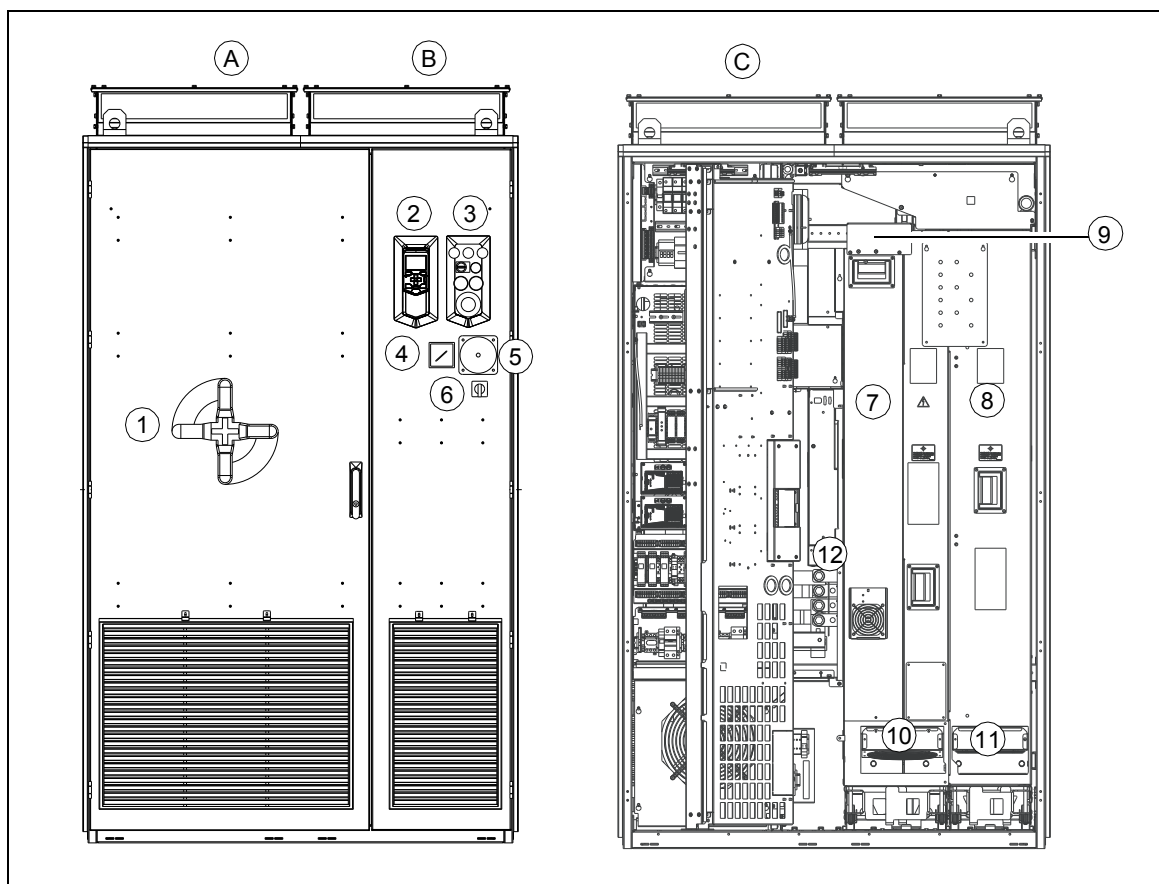

- A Main breaker and power cabling cubicle
- B Drive module cubicle
- C Swing-out frame on the drive module side open
- 1 Main switch-disconnector (Q1) handle
- 2 Drive control panel (see page 53)
- 3 Operating buttons and door lights (see page 52)
- 4 Indicators, for example, V-meter and A-meter
- 5 UL Type V-meter
- 6 V-meter switch
- 7 Drive module
- 8 LCL filter module
- 9 Charging switch/contactor (Q3)
- 10 Drive module main cooling fans (1...2 pcs, 690 V R11 module has only one fan)
- 11 LCL filter module cooling fan
- 12 Circuit board fan

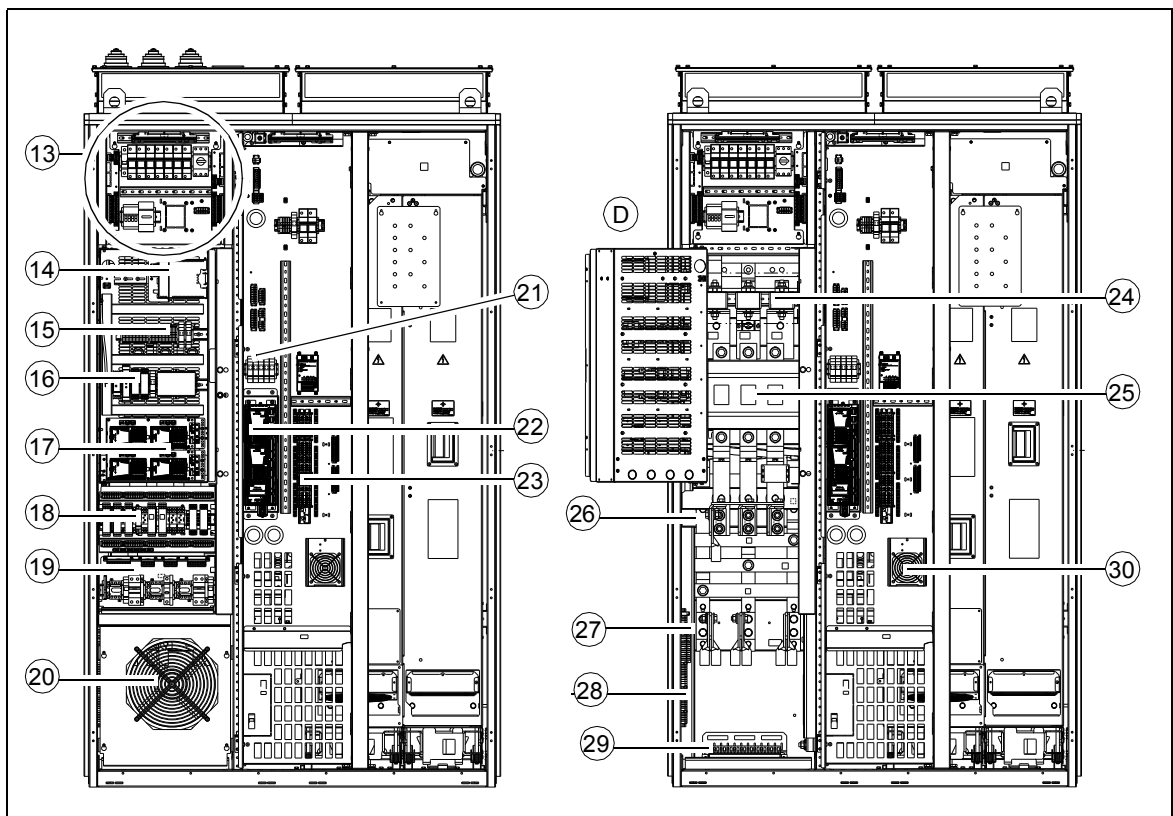

- D Swing-out frame
- 13 Main fuses for control devices, IP54 fan with option +B055, transformer with option +B055, V-meter (option +G334), starter for auxiliary motor fan (option +M600)
- 14 Buffering module and power supply unit
- 15 Terminal blocks X18 and X19
- 16 Ground fault monitoring and safety circuit component
- 17 Optional extension adapters and modules
- 18 Thermistor and PT100 relays (options +L505, +L506)
- 19 Components and connection terminals for options +G300, +G301, +G307, +G313
- 20 "Door fan"
- 21 Door light relays
- 22 Drive control unit
- 23 Terminal block (X504, option +L504) for external control cable connections to the control unit
- 24 Main AC fuses
- 25 Main switch-disconnector (Q1)
- 26 Input cable connection terminals behind the shroud (bottom entry)
- 27 Motor cable connection terminals (bottom entry)
- 28 X250 terminal block
- 29 Input and motor cable and control cable entry (bottom entry and exit)
- 30 Drive module auxiliary cooling fan

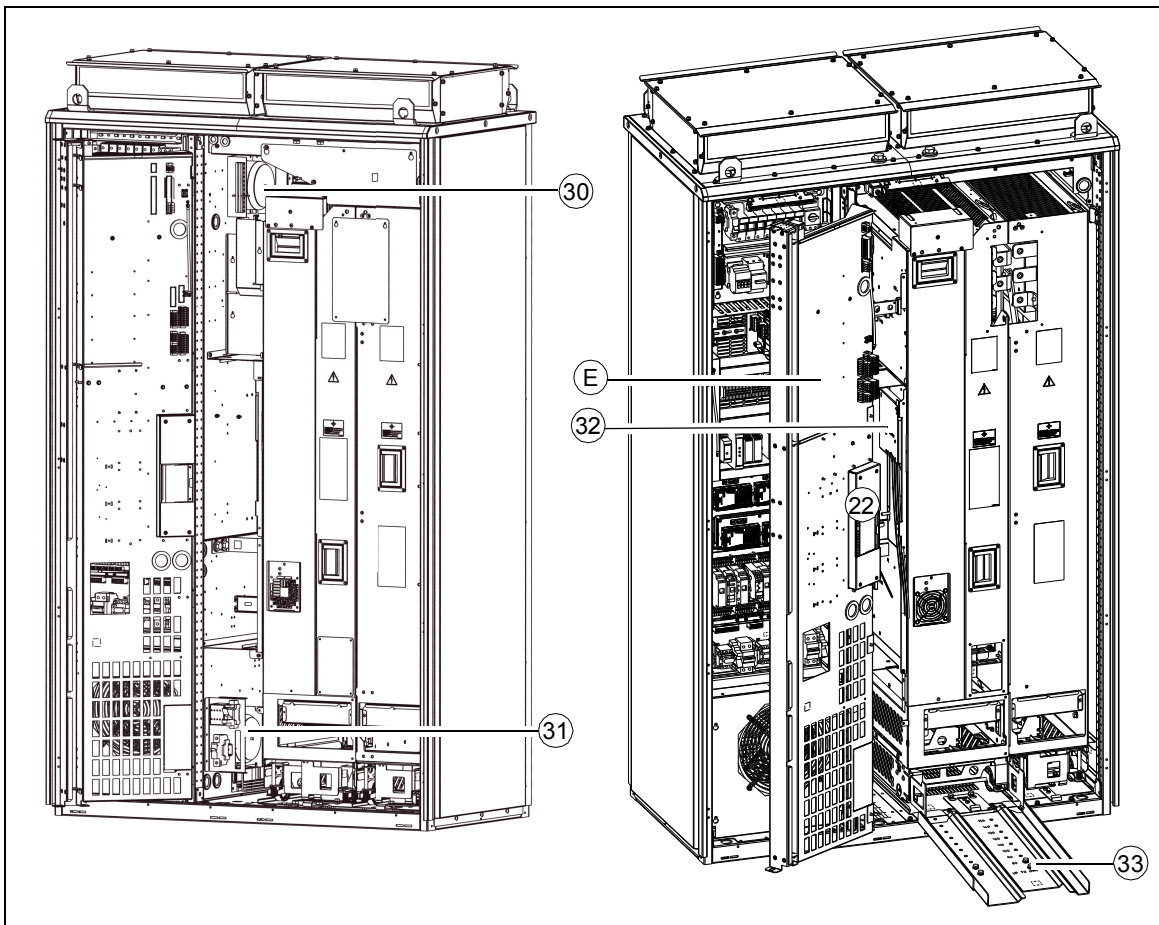

- E Swing-out frame
- 30 Auxiliary voltage transformer (T102) with option +B055 and distribution components (see page [107](#))
- 31 Auxiliary voltage transformer (T21) and distribution components (see page [107](#))
- 32 Line-side control unit
- 33 Extraction ramp

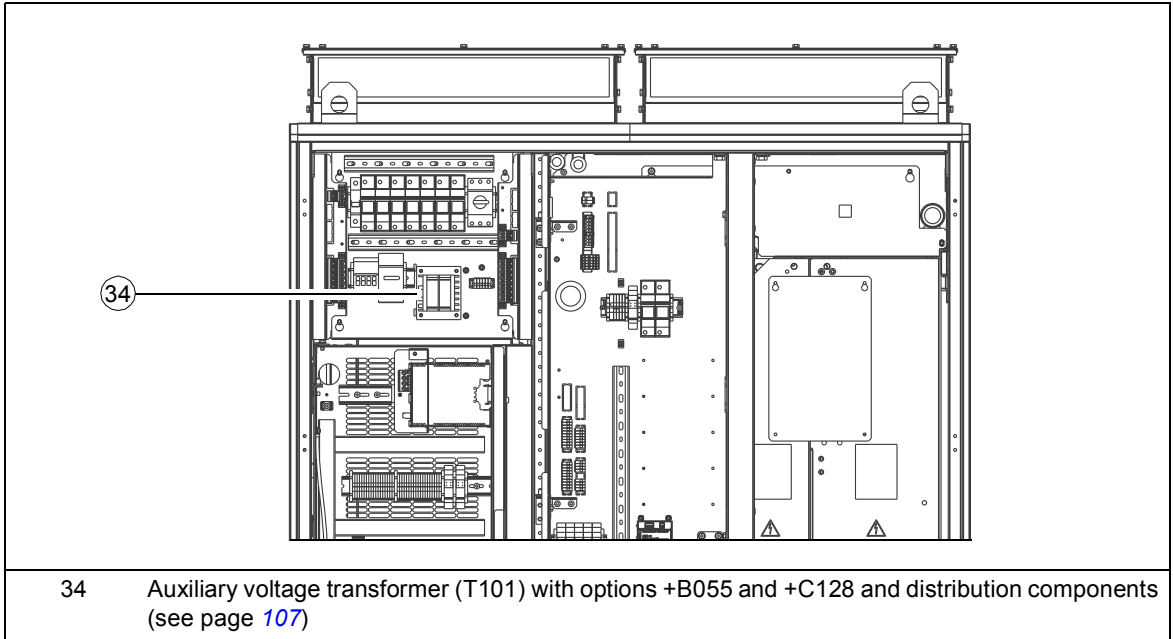

34 Auxiliary voltage transformer (T101) with options +B055 and +C128 and distribution components (see page 107)

Brake chopper cubicle option (+D150).

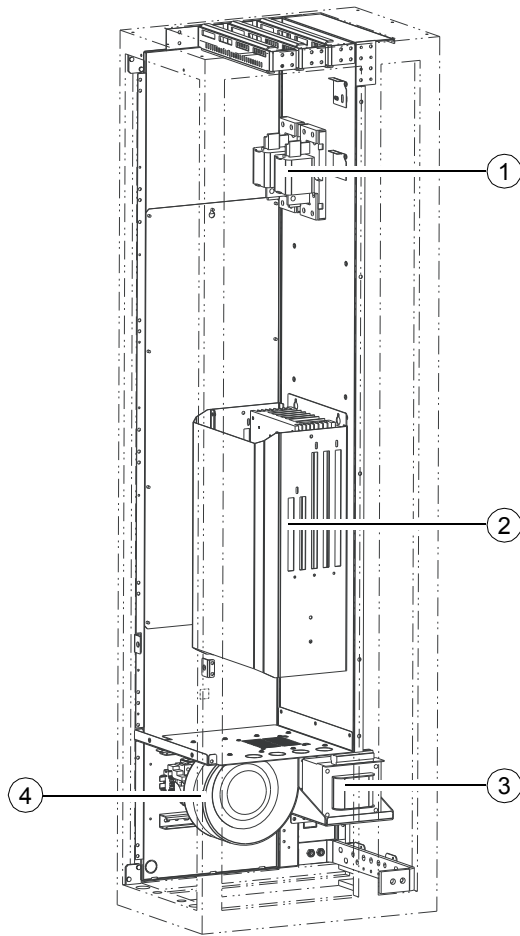

- |   |   |
|---|---|
| 1 | Fuses (F121.1...121.2)                  |
| 2 | Brake chopper module (T121.1)           |
| 3 | Auxiliary voltage transformer (T121.11) |
| 4 | Fan (G121.1)                            |

## Overview of power and control connections

The diagram shows the power connections and control interfaces of the drive.

### ■ Connection overview of R8

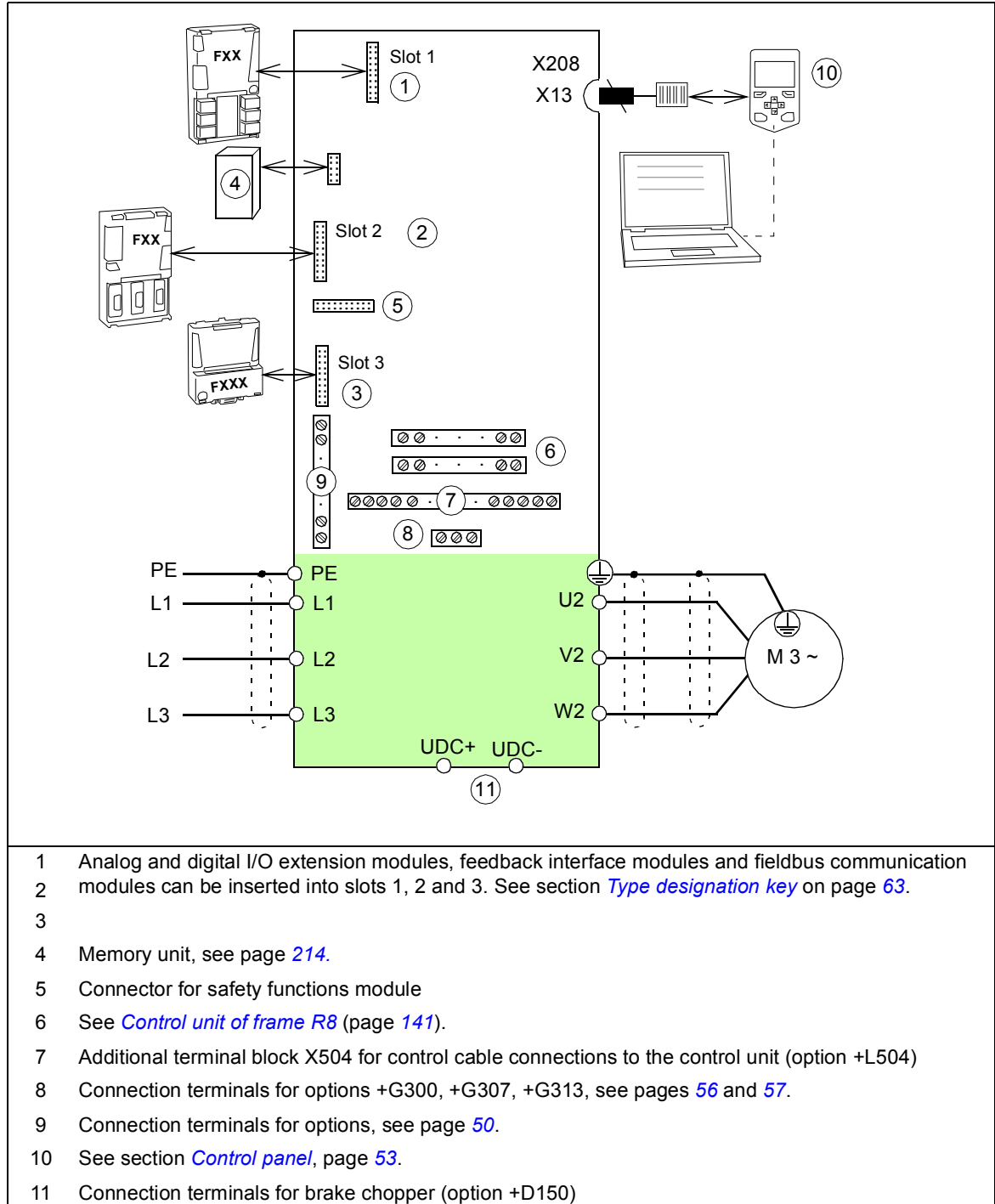

■ Connection overview of R11

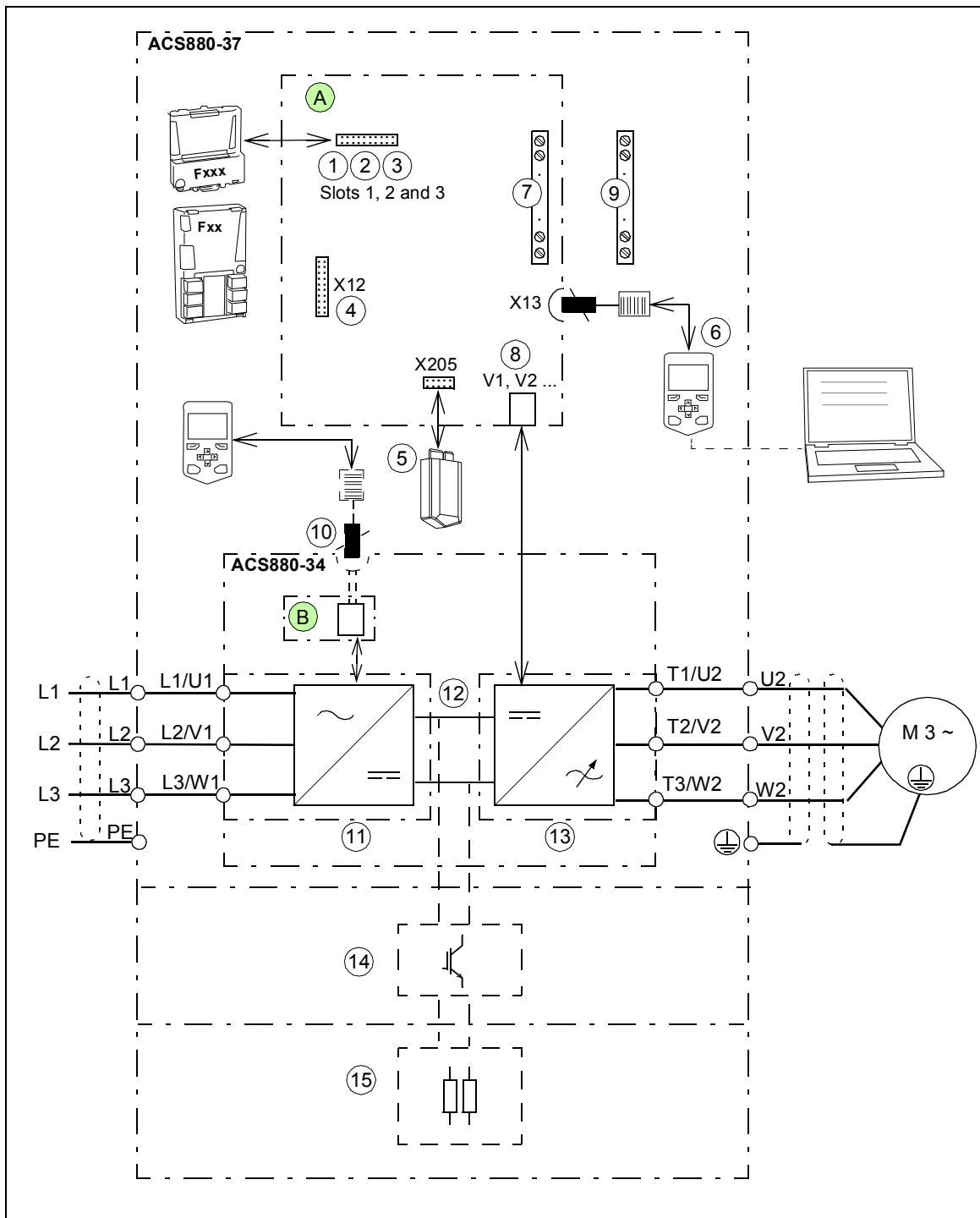

A Motor-side converter control unit (drive control unit)

B Line-side converter control unit

For the control unit connections, see also [Replacing the drive and LCL filter modules \(frame R11\)](#).

1 Analog and digital I/O extension modules, feedback interface modules and fieldbus communication modules can be inserted into slots 1, 2 and 3. See section [Type designation key](#) page 63.

3

4 Connection for FSO-xx safety functions module

5 Memory unit (see page 214)

6 See section [Control panel](#) (page 53)



- 7 Terminal blocks on the drive control unit. See chapter [Control unit of frame R11](#) (page 151). These terminals are optionally wired to terminal block X504 in the drive cabinet.
  - 8 Fiber optic link to the motor-side converter. Similarly, the line-side converter is connected to the line-side converter control unit with fiber optic cables.
  - 9 Terminal blocks for customer connections installed in the drive cabinet. Wiring details are given starting on page 117.
  - 10 Socket for external line-side converter control
  - 11 Line-side converter
  - 12 DC link
  - 13 Motor-side converter
  - 14 Brake chopper (option +D150)
  - 15 Brake resistors (option +D151)
-

## External control cable connection terminals

### Connection terminals of R8

The layout of external control cable connection terminals at the right-hand side of the drive cabinet is shown below. The composition depends on the options selected.

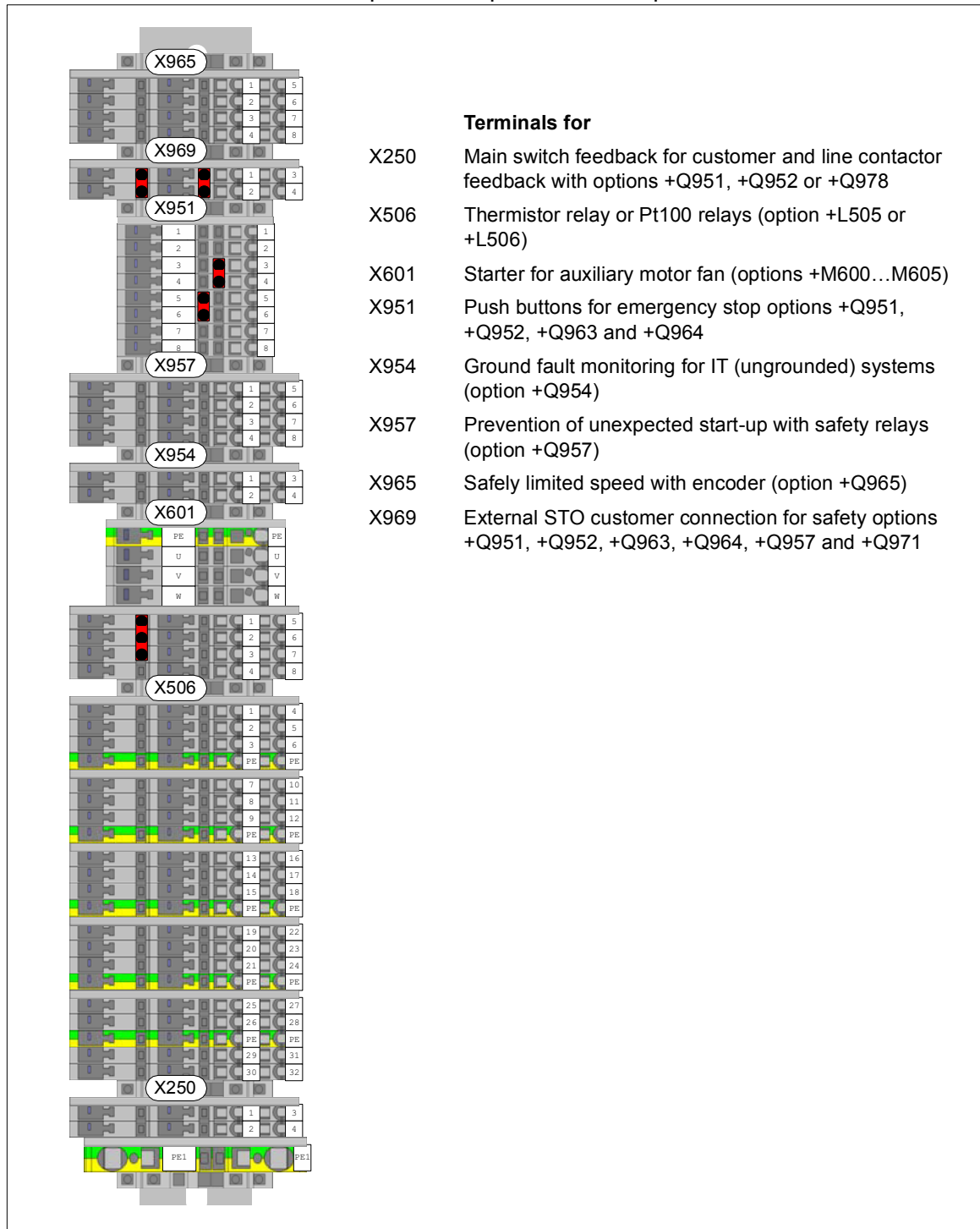

## Connection terminals of R11

The layout of external control cable connection terminals at the left-hand side of the drive cabinet is shown below. The composition depends on the options selected.

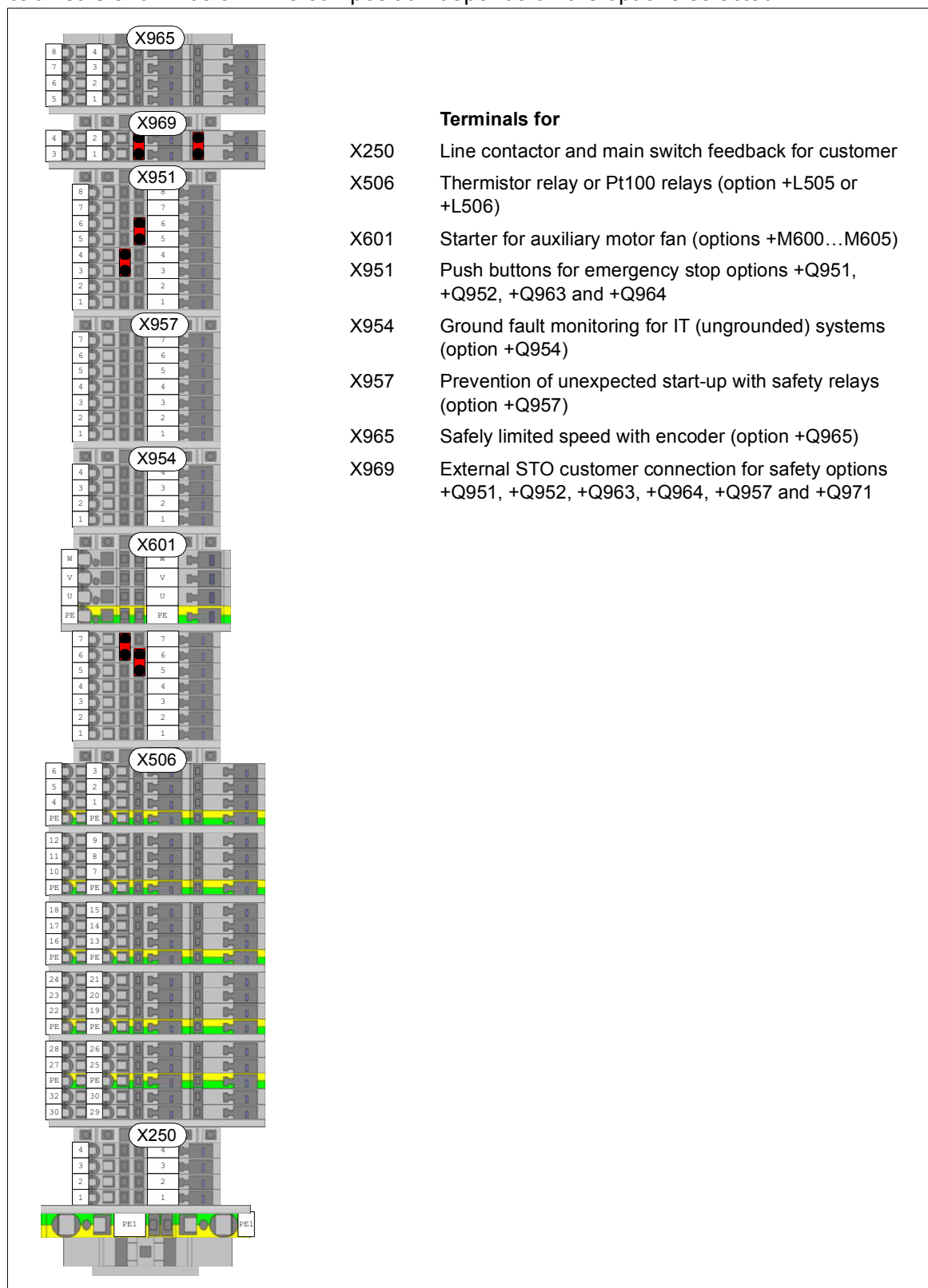

## Door switches and lights



	Label in English	Label in local language	Description				
1	READY	-	Ready light (option +G327)				
2	RUN	-	Run light (option +G328)				
3	FAULT	-	Fault light (option +G329)				
4	RUN/ENBL OFF      ON 	-	Run enable signal switch for the line-side converter with options +Q951, +Q952 and +Q978 <table border="1" style="width: 100%; border-collapse: collapse;"> <tr> <td style="width: 50px; text-align: center;">OFF</td> <td>Run enable signal off (starting the line-side converter not allowed). Opens the charging contactor.</td> </tr> <tr> <td style="text-align: center;">ON</td> <td>Run enable signal on (starting the line-side converter allowed). Closes the charging contactor Q3.</td> </tr> </table>	OFF	Run enable signal off (starting the line-side converter not allowed). Opens the charging contactor.	ON	Run enable signal on (starting the line-side converter allowed). Closes the charging contactor Q3.
OFF	Run enable signal off (starting the line-side converter not allowed). Opens the charging contactor.						
ON	Run enable signal on (starting the line-side converter allowed). Closes the charging contactor Q3.						
5	E-STOP RESET	-	Emergency stop reset push button (with emergency stop options only)				
6	EARTH FAULT	-	Ground (earth) fault light with option +Q954				
7	-	-	Reserved for application-engineered equipment				
8	EMERGENCY STOP	-	Emergency stop push button (with emergency stop options only)				

The layout depends on the options selected.

### ■ Main disconnecting device (Q1)

The main disconnecting device switches the main supply to the drive on and off. To disconnect the main supply, turn the switch-disconnector (frame R11) or switch fuse (frame R8) to the 0/OFF position.



**WARNING!** The main disconnecting device does not isolate the input power terminals or V-meter (option +G334) from the power line. To isolate the input power terminals and V-meter, open the main breaker of the supply transformer.

---

**Note:** The drive is not fitted with an auxiliary voltage switch. The auxiliary voltage is switched on and off by the main disconnecting device (Q1), and protected by fuses F21.1-2.

### ■ Other devices on the door

- Voltmeter (option +G334); comes with a phase selector switch. **Note:** The voltage is measured on the supply side of the main disconnecting device.
- AC current meter (option +G335) on one phase.

### ■ Control panel

The ACS-AP-W control panel is the user interface of the drive. It provides the essential controls such as Start/Stop/Direction/Reset/Reference, and the parameter settings for the motor and line-side converter control programs.

The control panel can be removed by pulling it forward from the top edge and reinstalled in reverse order. For the use of the control panel, see *ACS-AP assistant control panel user's manual* (3AUA0000085685 [English]) and the firmware manual.



### ■ Control by PC tools

There is a USB connector on the front of the panel that can be used to connect a PC to the drive. When a PC is connected to the control panel, the control panel keypad is disabled.

---

## Descriptions of cabinet options

**Note:** All options are not available for all drive types, do not coexist with certain other options, or may require additional engineering. Check actual availability with ABB.

### ■ Degree of protection

#### Definitions

According to IEC/EN 60529, the degree of protection is indicated by an IP code where the first numeral means protection against ingress of solid foreign objects, and the second numeral protection against ingress of water. The IP codes of the standard cabinet and options covered in this manual are defined below.

IP code	The equipment is protected ...	
	First numeral	Second numeral
IP22	against ingress of solid foreign objects $\geq$ 12.5 mm diameter *	against dripping (15° tilting) water
IP42	against ingress of solid foreign objects $\geq$ 1 mm	against dripping (15° tilting) water
IP54	dust-protected	against splashing water

\* meaning for protection of persons: against access to hazardous parts with finger

#### IP22 (standard)

The degree of protection of the standard drive cabinet is IP22 (UL Type 1). The air outlets at the top of the cabinet and the air inlet gratings are covered with metallic gratings. With doors open, the degree of protection of the standard cabinet and all cabinet options is IP20. The live parts inside the cabinet are protected against contact with clear plastic shrouds or metallic gratings.

#### IP42 (option +B054)

This option provides the degree of protection of IP42 (UL Type 1 Filtered). The air inlet gratings are covered with a metallic mesh between the inner and outer metallic gratings.

#### IP54 (option +B055)

This option provides the degree of protection of IP54 (UL Type 12). It provides the cabinet air inlets with filter housings containing folded board air filter mats between the inner and outer metallic gratings. An additional fan and filtered outlets on the cabinet roof are also included.

### ■ Channeled air inlet through bottom (option +C128)

This option provides air intake to the drive through the cabinet bottom when the drive is installed on an air duct in the floor.

See also [Air inlet through the bottom \(option +C128\)](#) on page 79.

Required options: IP54 degree of protection (+B055)

### ■ Channeled air outlet (option +C130)

This option provides a collar for fitting an air outlet duct. The collar is located on the cabinet roof. Depending on the equipment installed in each cubicle, the channeled air outlet either replaces, or adds to, the standard roof arrangement.

See also [Air outlet duct on the cabinet roof \(option +C130\)](#) on page 80.

### ■ Marine construction (option +C121)

The option includes the following accessories and features:

- reinforced mechanics
- grab railings
- door flush bolt which allows the door to open 90 degrees and prevents it from slamming close
- self-extinctive materials
- flat bars at base of the cabinet for attaching
- attaching braces at the top of the cabinet.

Required options: Appropriate additional wire marking option (see page 58) according to the requirements of the classification society

Related options: halogen-free materials and wiring (+G330)

### ■ UL listed (option +C129)

The option includes factory inspection of the cabinet according to UL 508C and the following accessories and features:

- US type main switch and fuses
- top entry and exit of cables
- US cable conduit entry (plain plate without ready-made holes)
- all components UL Listed/Recognized
- maximum supply voltage 600 V.

Related options: +H350 (bottom entry of cables), +H352 (bottom exit of cables) and +H358 (cable conduit entry)

The option is not available with +C121 (marine construction) or +E206 (sine output filter).

### ■ Plinth height (options +C164 and +C179)

The standard height of the cabinet plinth is 50 mm. These options specify a plinth height of 100 mm (+C164) or 200 mm (+C179).

### ■ Seismic design (option +C180)

This option involves seismic capability according to International building code 2012, test procedure ICC-ES AC-156. The installation level must not exceed 25% of the height of the building, and SDS (installation site specific spectral acceleration response) must not exceed 2.0 g.

The option includes the following accessories and features:

- reinforced plinth
- flat bars at base of the cabinet for attaching.

### ■ Resistor braking (options +D150 and +D151)

See chapter [Resistor braking](#) on page 277.

---

### ■ Empty cubicles (options +C196, +C197, +C198, +C199, +C200, +C201)

The option adds an empty 400, 600 or 800 mm wide cubicle to the left or right end of the cabinet. The cubicle is equipped with blank power cable exits both at the top and the bottom.

### ■ EMC filters (option + E202)

See section [Type designation key](#) on page 63 and sections [Compliance with the European EMC Directive](#) on page 235 and [Compliance with EN 61800-3:2004 + A1:2012](#) on page 238.

More information: *Technical Guide No. 3 – EMC Compliant Installation and Configuration for a Power Drive System* (3AFE61348280 [English])

### ■ du/dt filter (option +E205)

The du/dt filter protects the motor insulating system by reducing the voltage rise speed at the motor terminals. The filter also protects the motor bearings by reducing the bearing currents.

More information on when the option is required: See section [Examining the compatibility of the motor and drive](#) on page 83.

### ■ Sine filter (option +E206)

A sine filter provides true sinusoidal voltage waveform at the drive output by suppressing the high-frequency voltage components of the output. These high-frequency components cause stress to motor insulation as well as output transformer saturation (if present).

The sine filter option consists of three single-phase reactors and delta-connected capacitors at the output of the drive. The filter is fitted in a separate cubicle. A du/dt filter can be replaced with a sine filter.

More information: see page 89.

### ■ Common mode filter (option +E208)

The common mode filter contains ferrite rings mounted around the AC output busbars in the drive module. The filter protects the motor bearings by reducing the bearing currents.

More information on when the option is required: See section [Examining the compatibility of the motor and drive](#) on page 83.

### ■ Cabinet heater with external supply (option +G300)

The option contains:

- 50 W or 100 W heating elements in the cabinet
- load switch for providing electrical isolation during service
- miniature circuit breaker for overcurrent protection
- terminal block for external power supply.

The heater prevents humidity condensation inside the cabinet when the drive is not running. The power output of the semiconductor-type heating elements depends on the environmental temperature. The customer must switch the heating off when it is not needed by cutting the supply voltage off.

The customer must supply the heater from an external 110...240 V AC power source.

---



See also

- [Powering the heating and lighting equipment \(options +G300, +G301 and +G313\)](#) on page 121
- [Auxiliary circuit power consumption](#) on page 233
- circuit diagrams delivered with drive for the actual wiring.

### ■ Cabinet lighting (option +G301)

This option contains LED lighting fixtures in each cubicle (except brake resistor cubicles) and a 24 V DC power supply. The lighting is powered from the same external 110...240 V AC power source as the cabinet heater (option +G300).

### ■ Terminals for external interruptible control voltage (option +G307)

The option provides terminals for connecting external interruptible control voltage to the control unit and control devices when the drive is not running.

See also

- [Supplying power for the auxiliary circuits](#) on page 100
- [Connecting an auxiliary voltage supply \(UPS, option +G307\)](#) on page 117
- circuit diagrams delivered with drive for the actual wiring.

### ■ Output for motor space heater (option +G313)

The option contains:

- load switch for providing electrical isolation during service
- miniature circuit breaker for overcurrent protection
- terminal block for external supply and heating element(s) connection.

The heater is off when the drive is operating. The customer controls the heating elements in the motor windings on and off with the external supply. The power and voltage of the motor heater depend on the motor.

See also

- [Supplying power for the auxiliary circuits](#) on page 100
- [Powering the heating and lighting equipment \(options +G300, +G301 and +G313\)](#) on page 121
- circuit diagrams delivered with drive for the actual wiring.

### ■ Ready/Run/Fault lights (options +G327...G329)

These options provide “ready” (+G327, white), “run” (+G328, green) and “fault” (+G329, red) lights installed on the cabinet door.

### ■ Halogen-free materials and wiring (option G330)

The option provides halogen-free cable ducts, control wires and wire sleeves, thus reducing toxic fire gases.

### ■ V-meter with selector switch (option +G334)

The option contains a voltmeter and a selector switch on the cabinet door. The switch selects the two input phases across which the voltage is measured.

---

**A-meter in one phase (option +G335)**

The option contains an ammeter that reads the current flowing through one (L1) input phase.



**Additional wire markings (options +G340 and +G342)**

**Standard wire markings**

As standard, wires and terminals are marked as follows:

- Plug-in connectors of wire sets: Connector labeled with designation (for example, “X1”). Both the connector and the individual wires are marked with pin numbers.
- Wires without a connector: Connector designation and pin number printed on wire (for example, “X1:7”).
- Fiber optic pairs: Component and connector designation printed on marker tape.
- Main input, output and PE terminals: Connector identifier (for example, “U1”, “PE”) printed on sticker on terminal, or on insulating material close to the terminal. PE cables marked with yellow/green tape.

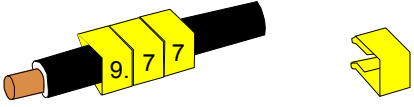
The wire marking options are described below.

Additional markings	
+G340	<p>Equipment pin numbers are marked with snap-on markers on wires between modules and on wires connected to equipment, terminal blocks and detachable screw terminals. Plug-in connector identifications are marked on labels near the connectors. The label holders are attached around conductor bundles. Main circuit conductors are marked with white tape or printing.</p> 
+G342	<p>Equipment identifications and terminal block pin numbers and remote addresses are marked with hoses or rings on wires between modules, and on wires connected to equipment, terminal blocks and detachable screw terminals. Plug-in connector identifications are marked on labels attached around the conductor bundles near the connectors. Main circuit conductors are marked with white tape or printing.</p> <p><b>Note:</b> Even wires with equipment and pin identifiers ready printed on the wire insulation are marked with rings or hoses. Remote end addresses <b>are not</b> marked on wire ends that are connected to plug-in connectors. Short and obvious connections are marked with printing only.</p> 

**Bottom cable entry/exit (options +H350 and +H352)**

For UL Listed (+C129) units, the default input and output cabling direction is through the roof of the cabinet. The bottom entry (+H350) and bottom exit (+H352) options provide power and control cable entries at the floor of the cabinet.

For non-UL Listed units, bottom entry/exit is the default cabling arrangement.

### ■ Top cable entry/exit (options +H351 and +H353)

For non-UL Listed units, the default input and output cabling direction is through the bottom of the cabinet. The top entry (+H351) and top exit (+H353) options provide power and control cable entries at the roof of the cabinet. The entries are equipped with grommets and 360° grounding hardware.

For UL Listed (+C129) units, top entry/exit is the default cabling arrangement.

### ■ Cable conduit entry (option +H358)

The option provides US/UK conduit plates (plain 3 m steel plates without any ready-made holes). US/UK conduit plates are provided as standard with options +C129 and +C134 instead of the normal cable entries.

### ■ Additional terminal block X504 (option +L504)

The standard terminal blocks of the drive control unit are wired to the additional terminal block at the factory for customer control wiring. The terminals are spring loaded.

Cables accepted by the terminals:

- solid wire 0.08 to 4 mm<sup>2</sup> (28 to 12 AWG)
- stranded wire with ferrule 0.14 to 2.5 mm<sup>2</sup> (24 to 14 AWG)
- stranded wire without ferrule 0.08 to 2.5 mm<sup>2</sup> (28 to 12 AWG).

Stripping length: 10 mm (0.4 in)

**Note:** The optional modules inserted in the slots of the control unit (or optional FEA-03 extension adapter) are not wired to the additional terminal block. The customer must connect the optional module control wires directly to the modules.

### ■ Thermal protection with PTC relays (options +L505, +2L505, +L513, +2L513)

PTC thermistor relay options are used for the overtemperature supervision of motors equipped with PTC sensors. When the motor temperature rises to the thermistor wake-up level, the thermistor resistance increases sharply. The relay detects the change and indicates motor overtemperature through its contacts.

#### **+L505, +2L505, +L513, +2L513**

Option +L505 provides a thermistor relay and a terminal block. The terminal block has connections for the measuring circuit (one to three PTC sensors in series), the output indication of the relay, and an optional external reset button. The relay can be reset either locally or externally, or the reset circuit can be jumpered for automatic reset.

The output indication of the relay can be wired by the customer for example to

- the main contactor or breaker control circuit of the drive, to open it in case of motor overtemperature,
- the appropriate digital input of the drive, to trip the drive and generate a fault message in case of motor overtemperature, or
- an external monitoring circuit.

Option +L513 is an ATEX-certified thermal protection function that has the same external connectivity as +L505. In addition, +L513 comes with +Q971 (ATEX-certified safe disconnection function) and is wired at the factory to activate the Safe torque off function of the drive in an overtemperature situation. A manual reset for the protection function is required by Ex/ATEX regulations. For more information, see *ATEX-certified motor thermal*

---

*protection functions for cabinet-built ACS880 drives (options +L513+Q971 and +L514+Q971) user's manual (3AXD50000014979 [English]).*

Options +2L505 and +2L513 duplicate options +L505 and +L513 respectively, containing the relays and connections for two separate measurement circuits.

#### **+L536, +L537**

An alternative to a thermistor relay option is the FPTC-01 (option +L536) or FPTC-02 (option +L537, also requires option +Q971) thermistor protection module. The module mounts onto the drive control unit, and has reinforced insulation to keep the control unit PELV-compatible. The connectivity of the FPTC-01 and the FPTC-02 is the same. FPTC-02 is an ATEX-certified thermistor protection module, Type Examined as a protective device within the scope of the European ATEX Product Directive.

For protection purposes, the FPTC has a “fault” input for the PTC sensor. An overtemperature situation executes the SIL/PL-capable SMT (Safe motor temperature) safety function by activating the Safe torque off function of the drive.

The FPTC also has a “warning” input for the sensor. When the module detects overtemperature through this input, it sends a warning indication to the drive.

For more information and wiring examples, see the module manuals and the circuit diagrams delivered with the drive.

#### **More information**

See

- firmware manual for parameter settings
- *ATEX-certified motor thermal protection functions for cabinet-built ACS880 drives (options +L513+Q971 and +L514+Q971) user's manual (3AXD50000014979 [English])*
- *FPTC-01 thermistor protection module (option +L536) for ACS880 drives user's manual (3AXD50000027750 [English])*
- *FPTC-02 ATEX-certified thermistor protection module, Ex II (2) GD (option +L537 +Q971) for ACS880 drives user's manual (3AXD50000027782 [English])*
- [Wiring the PTC thermistor relay\(s\) \(options +L505, +2L505, +L513, +2L513\)](#) on page 118
- circuit diagrams delivered with the drive for the actual wiring.

#### **Pt100 relays (options +2L506, +3L506, +5L506, +8L506, +L514)**

Pt100 temperature monitoring relays are used for overtemperature supervision of motors equipped with Pt100 sensors. For example, there can be three sensors to measure the temperature of the motor windings and two sensors for the bearings.

The standard Pt100 relay options include two (+2L506), three (+3L506), five (+5L506) or eight (+8L506) relays. The monitoring relays are connected to one to three auxiliary relays whose outputs are wired at the factory to a terminal block. The sensors are to be connected by the customer to the same terminal block.

As the temperature rises, the sensor resistance increases linearly. At an adjustable wake-up level, the monitoring relay de-energizes its output which then trips one of the auxiliary relays.

---

The output indication of the auxiliary relays can be wired by the customer for example to

- the main contactor or breaker control circuit of the drive, to open it in case of motor overtemperature,
- the appropriate digital input of the drive, to trip the drive and generate a fault message in case of motor overtemperature, or
- an external monitoring circuit.

Options +3L514 (3 relays), +5L514 (5 relays) are ATEX-certified thermal protection functions that have the same external connectivity as +nL506. In addition, each monitoring relay has a 0/4...20 mA output that is available on the terminal block. Option +nL514 comes with option +Q971 (ATEX-certified safe disconnection function) as standard and is wired at the factory to activate the Safe torque off function of the drive in an overtemperature situation. As the monitoring relay does not have a reset functionality, the manual reset required by Ex/ATEX regulations must be implemented using drive parameters. For more information, see *ATEX-certified motor thermal protection functions for cabinet-built ACS880 drives (options +L513+Q971 and +L514+Q971) user's manual* (3AXD50000014979 [English]).

See also

- firmware manual for parameter settings
- *ATEX-certified motor thermal protection functions for cabinet-built ACS880 drives (options +L513+Q971 and +L514+Q971) user's manual* (3AXD50000014979 [English])
- [Wiring the Pt100 relays \(option +nL506\)](#) on page 119 or [Wiring the Pt100 relays \(option +nL514\)](#) on page 120
- Pt100 relay alarm and trip limit setting instructions on page 164
- circuit diagrams delivered with the drive for the actual wiring.

## ■ Starter for auxiliary motor fan (options +M600...+M605)

### What the option contains

The option provides switched and protected connections for one 3-phase auxiliary motor fan. Each fan connection is equipped with

- fuses
- a manual motor starter switch with an adjustable current limit
- a contactor controlled by the drive, and
- terminal block X601 for customer connections.

### Description

The output for the auxiliary fan is wired from the 3-phase supply voltage to terminal block X601 through a motor starter switch and a contactor. The contactor is operated by the drive. The 230 V AC control circuit is wired through a jumper on the terminal block; the jumper can be replaced by an external control circuit.

The starter switch has an adjustable trip current limit, and can be opened to permanently switch the fan off.

The statuses of both the starter switch and the fan contactor are wired to the terminal block.

See the circuit diagrams delivered with the drive for the actual wiring.

---

## Type designation label

The type designation label includes an IEC and UL (NEC) rating, appropriate markings, a type designation and a serial number, which allow identification of each unit.

Quote the complete type designation and serial number when contacting technical support.

A sample label is shown below.

**ABB**  
MADE IN ESTONIA  
ABB Oy  
Hiomotie 13  
00380 Helsinki  
Finland

**1** ACS880-37-0442A-3+B055+G340+K454+L504+Q951

**2** ABB Oy  
Hiomotie 13  
00380 Helsinki  
Finland

**3** FRAME  
R11

**4** Air cooling  
**5** IP54

**6** Input U1 3~ 400 VAC  
I1 401 A  
f1 50/60 Hz  
Output U2 3~ 0...U1  
I2 442 A  
f2 0...500 Hz  
Sn 306 kVA

**7** Icc 65 kA

**8** EAC, CE, TUV HONOR, Safety Approved, e

**9** S/N: 8180701519

1	Type designation, see section <a href="#">Type designation key</a> below.
2	Manufacturing address
3	Frame size
4	Cooling method
5	Degree of protection
6	Ratings, see section <a href="#">Ratings</a> on page 217 and <a href="#">Electrical power network specification</a> on page 231.
7	Short-circuit withstand strength, see section <a href="#">Electrical power network specification</a> on page 231.
8	Valid markings
9	Serial number. The first digit of the serial number refers to the manufacturing plant. The next four digits refer to the unit's manufacturing year and week, respectively. The remaining digits complete the serial number so that there are no two units with the same number.

## Type designation key

The type designation contains information on the specifications and configuration of the drive. The first digits from left express the basic configuration (for example, ACS880-37-0650A-3). The optional selections are given thereafter, separated by plus signs, for example, +E202. The main selections are described below. Not all selections are available for all types. For more information, refer to *ACS880 Ordering Information* (3AXD10000052815, available on request).

CODE	DESCRIPTION
<b>Basic codes</b>	
ACS880	Product series
37	When no options are selected: cabinet-installed drive, IP22 (UL Type 1), switch fuse (R8), main switch-disconnector (R11), aR fuses, line contactor in frame R11, ACS-AP-W Assistant control panel, EMC filter of category C3 for second environment TN (grounded) and IT (ungrounded) systems in R11, no EMC filter in R8, ACS880 primary control program, Safe torque off function, coated circuit boards, bottom entry and exit of cables, USB memory stick containing circuit diagrams, dimension drawings and manuals.
<b>Size</b>	
xxxx	Refer to the rating tables (page <a href="#">217</a> )
<b>Voltage range</b>	
3	380...415 V. This is indicated in the type designation label as typical input voltage level 3 ~ 400 V AC.
5	380...500 V. This is indicated in the type designation label as typical input voltage levels 3 ~ 400/480/500 V AC.
7	525...690 V. This is indicated in the type designation label as typical input voltage levels 3 ~ 525/600/690 V AC.
<b>Option codes (plus codes)</b>	
<b>Degree of protection</b>	
B054	IP42 (UL Type 1 Filtered)
B055	IP54 (UL Type 12)
<b>Construction</b>	
C121	Marine construction (reinforced mechanics and attaching, handrails, self-extinctive materials). Not with +C129, +C134, +C164, +C179, +C180 and +E206)
C128	Air inlet through bottom of cabinet (+B055 required)
C129	UL Listed (US type main switch fuse, top entry and exit of cables, cable conduit entries, all components UL Listed or Recognized, max. supply voltage 600 V) Not with +C121 and +E206.
C130	Channeled air outlet (not with +H351, +H353, +C129 and +D151)
C132	Marine type approval (+C121 marine construction required)
C134	CSA Approved (US/CSA type main switch fuse, bottom entry and exit of cables, cable conduit entries, all components UL/CSA Listed or Recognized, max. supply voltage 600 V). Not with +C121 and +E206.
C164	Plinth height 100 mm (not with +C121 or +C180)
C179	Plinth height 200 mm (not with +C121 or +C180)
C180	Seismic design (not with +C121, +C164, +C179 and +E206)
C196	Empty cubicle 400 mm on right side
C197	Empty cubicle 600 mm on right side
C198	Empty cubicle 800 mm on right side
C199	Empty cubicle 400 mm on left side
C200	Empty cubicle 600 mm on left side
C201	Empty cubicle 800 mm on left side

## 64 Operation principle and hardware description

CODE	DESCRIPTION
<b>Resistor braking</b>	
D150	Brake chopper
D151	Brake resistors (not with +B055, +C130, marine, UL and CSA)
<b>Filters</b>	
E200	EMC filter for 2nd environment, TN (grounded) system, category C3 (for R8)
E201	EMC filter for 2nd environment, IT (ungrounded) system, category C3 (for R8)
E202	EMC filter for first environment, TN (grounded) system, category C2 (not for 690 V; +E208 required for R11)
E205	du/dt filter
E206	Sine output filter (not with +C121, +C129, +C134 and +C180)
E208	Common mode filter
<b>Cabinet equipment</b>	
G300	Cabinet and module heating elements (external supply)
G301	Cabinet lighting
G307	Terminals for connecting external control voltage (230 V AC or 115 V AC, for example, UPS)
G313	Output for motor heater (external supply)
G327	Ready light, white
G328	Run light, green
G329	Fault light, red
G330	Halogen-free wiring and materials (not with +C129 or +C134)
G334	V-meter with selector switch
G335	A-meter in one phase
G340	See section <a href="#">Additional wire markings (options +G340 and +G342)</a> on page 58.
G342	
<b>Cabling</b>	
H350	Bottom entry
H351	Top entry
H352	Bottom exit
H353	Top exit
H358	Cable conduit entry (US/UK)
<b>Control panel</b>	
J425	ACS-AP-I Assistant control panel (Non-Bluetooth control panel)
<b>Fieldbus adapters</b>	
K451	FDNA-01 DeviceNet™ adapter module
K454	FPBA-01 PROFIBUS DP adapter module
K457	FCAN-01 CANopen adapter module
K458	FSCA-01 RS-485 adapter module
K462	FCNA-01 ControlNet™ adapter module
K469	FECA EtherCat adapter module
K470	FEPL EtherPOWERLINK adapter module
K473	FENA-11 Ethernet adapter module for EtherNet/IP™, Modbus TCP and PROFINET IO protocols
K475	FENA-21 Ethernet adapter module for EtherNet/IP™, Modbus TCP and PROFINET IO protocols, 2-port
<b>I/O extensions and feedback interfaces</b>	
L500	FIO-11 analog I/O extension module
L501	FIO-01 digital I/O extension module



CODE	DESCRIPTION
L502	FEN-31 HTL incremental encoder interface module
L503	FDCO-01 optical DDCS communication adapter module
L504	Additional I/O terminal block
L505	Thermistor relay (1 or 2 pcs)
L506	Pt100 relay (2, 3, 5 or 8 pcs)
L508	FDCO-02 optical DDCS communication adapter module
L513	ATEX-certified thermal protection with PTC sensors (1 or 2 pcs, +Q971 required)
L514	ATEX-certified thermal protection with Pt100 relays (3 or 5 pcs, +Q971 required)
L515	FEA-03 I/O extension adapter module (+L503 or +L508 required)
L516	FEN-21 resolver interface module
L517	FEN-01 TTL incremental encoder interface module
L518	FEN-11 TTL absolute encoder interface module
L521	FSE-31 pulse encoder interface (+Q972 required)
L525	FAIO-01 analog I/O extension module
L526	FDIO-01 digital I/O extension module
L536	FPTC-01 thermistor protection module (not with +L505, +L506, +L513, +L514, +L537, +Q957, +Q951, +Q952, +Q963 and +Q964)
L537	FPTC-02 ATEX-certified thermistor protection module (+Q971 required; not with +L505, +L506, +L513, +L521, +L536, +Q957, +Q951, +Q952, Q963, +Q964)
<b>Starter for auxiliary motor fan</b>	
M600	Trip limit setting range: 1 ... 1.6 A
M601	Trip limit setting range: 1.6 ... 2.5 A
M602	Trip limit setting range: 2.5 ... 4 A
M603	Trip limit setting range: 4 ... 6.3 A
M604	Trip limit setting range: 6.3 ... 10 A
M605	Trip limit setting range: 10...16 A
<b>Control program</b>	
N5000	Winder control program
N5050	Crane control program (not with +Q952, +Q963, +Q964 and +Q979)
N5100	Winch control program (not with +Q952, +Q963, +Q964 and +Q979)
N5200	PCP control program
N5300	Test bench control program
N5450	Override control program (not with +Q972 and +Q973)
N5600	ESP control program
N7502	Control program for synchronous reluctance motors (SynRM)
N8010	Application programming (not with +N5000, +N5050, +N5100, +N5200 or +N5450)
<b>Specialties</b>	
P902	Customized
P904	Extended warranty
P912	Seaworthy packaging
P913	Special color
P929	Container packaging
<b>Safety functions</b>	
Q950	Prevention of unexpected start-up with FSO-xx safety functions module, by activating the Safe torque off function
Q951	Emergency stop (category 0) with safety relays, by opening the main breaker/contactors

CODE	DESCRIPTION
Q952	Emergency stop (category 1) with safety relays, by opening the main breaker/contactator (+L501 required; not with +N5000 and +N5050)
Q954	Ground fault monitoring for IT (ungrounded networks)
Q957	Prevention of unexpected start-up with safety relays, by activating the Safe torque off function
Q963	Emergency stop (category 0) with safety relays, by activating the Safe torque off function (not with +N5000 and +N5050)
Q964	Emergency stop (category 1) with safety relays, by activating the Safe torque off function (+L501 required; not with +N5000 and +N5050)
Q965	Safely limited speed with encoder (+Q972 and +L521 required)
Q971	ATEX-certified safe disconnection function (+L513, +L514 or +L537 required; not with +Q957, +Q951, +Q952, +Q963 and +Q964)
Q972	FSO-21 safety functions module (not with +Q957, +Q951, +Q952, +Q963, +Q964 and +Q972)
Q973	FSO-12 safety functions module (not with +Q957, +Q951, +Q952, +Q963, +Q964 and +Q972)
Q978	Emergency stop (configurable for category 0 or 1) with FSO-xx safety functions module, by opening the main breaker/contactator
Q979	Emergency stop (configurable for category 0 or 1) with FSO-xx safety functions module, by activating the Safe torque off function (not with +N5000 and +N5050)
Q982	PROFIsafe with FSO-xx safety functions module and FENA-21 Ethernet adapter module
<b>Full set of printed manuals in the selected language</b>	
<b>Note:</b> The delivery may include manuals in English if the requested language is not available.	
R700	English
R701	German
R702	Italian
R703	Dutch
R704	Danish
R705	Swedish
R706	Finnish
R707	French
R708	Spanish
R709	Portuguese
R711	Russian
R713	Polish

# 4

## Mechanical installation

---

### Contents of this chapter

This chapter describes the mechanical installation procedure of the drive.



### Examining the installation site

Examine the installation site:

- The installation site is sufficiently ventilated or cooled to remove heat from the drive. <sup>1)</sup>
- The ambient conditions of the drive meet the specifications. <sup>1)</sup>
- The wall behind the unit is of non-flammable material.
- There is enough free space above the drive to enable cooling air flow, service and maintenance.
- The floor that the unit is installed on is of non-flammable material, as smooth as possible, and strong enough to support the weight of the unit. Check the floor flatness with a spirit level. The maximum allowed deviation from the surface level is 5 mm in every 3 meters. Level the installation site, if necessary, as the cabinet is not equipped with adjustable feet.

<sup>1)</sup> The heat losses and ambient conditions are specified in chapter [Technical data](#).

---

**Note:** Try to avoid installing the drive on an elevated platform or a recess. The module extraction/installation ramp supplied with the drive can only be used on a level floor.

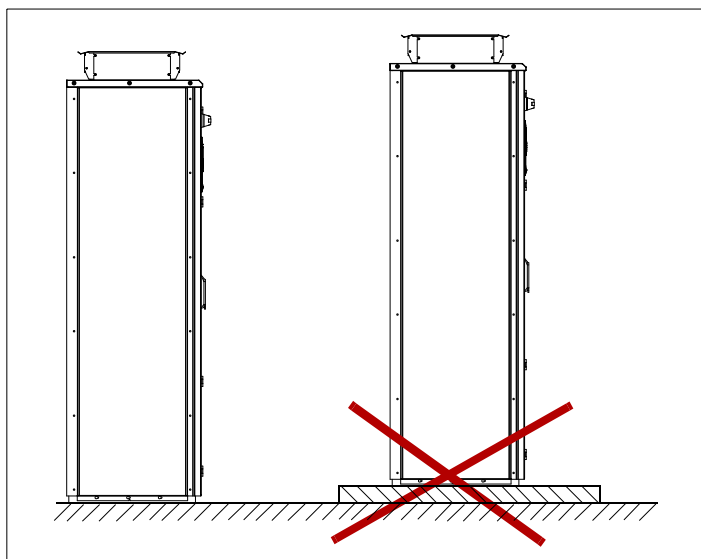

## Necessary tools

The tools required for moving the unit to its final position, attaching it to the floor and wall and tightening the connections are listed below:

- crane, fork-lift or pallet truck (check load capacity!), slate/spud bar, jack and rollers
- Pozidriv and Torx screwdrivers
- torque wrench
- set of wrenches or sockets.



## Checking the delivery

The drive delivery contains:

- drive cabinet or cabinet line-up (if option cabinets are ordered)
- optional modules (if ordered) installed onto the control unit at the factory
- appropriate drive and optional module manuals
- delivery documents.

Check that there are no signs of damage. Before attempting installation and operation, check the information on the type designation labels of the drive to verify that the delivery is of the correct type. See section [Type designation key](#) on page 63.

## Moving and unpacking the drive

Move the drive in its original packaging to the installation site as shown below to avoid damaging the cabinet surfaces and door devices. When you are using a pallet truck, check its load capacity before you move the drive.

The drive cabinet is to be moved in the upright position.

The center of gravity of the cabinet is high. Be therefore careful when moving the unit. Avoid tilting.

### ■ Moving the drive in its packaging

The diagram illustrates two methods for moving the drive cabinet in its original packaging. Method A shows the cabinet being lifted by four orange slings attached to a central hook. Method B shows the cabinet being moved by a yellow forklift. The cabinet is shown in three views: a perspective view (A), a front view with dimensions, and a side view. The dimensions are: height 2321 mm (91.38 in), width R8:1088 mm (42.83 in), and depth R11:1450 mm (57.09 in). A green wrench icon is located on the right side of the diagram.

A	Lifting the transport package with slings.
1	Lifting points
B	Lifting the transport package with forklift

■ Moving the crate with a forklift

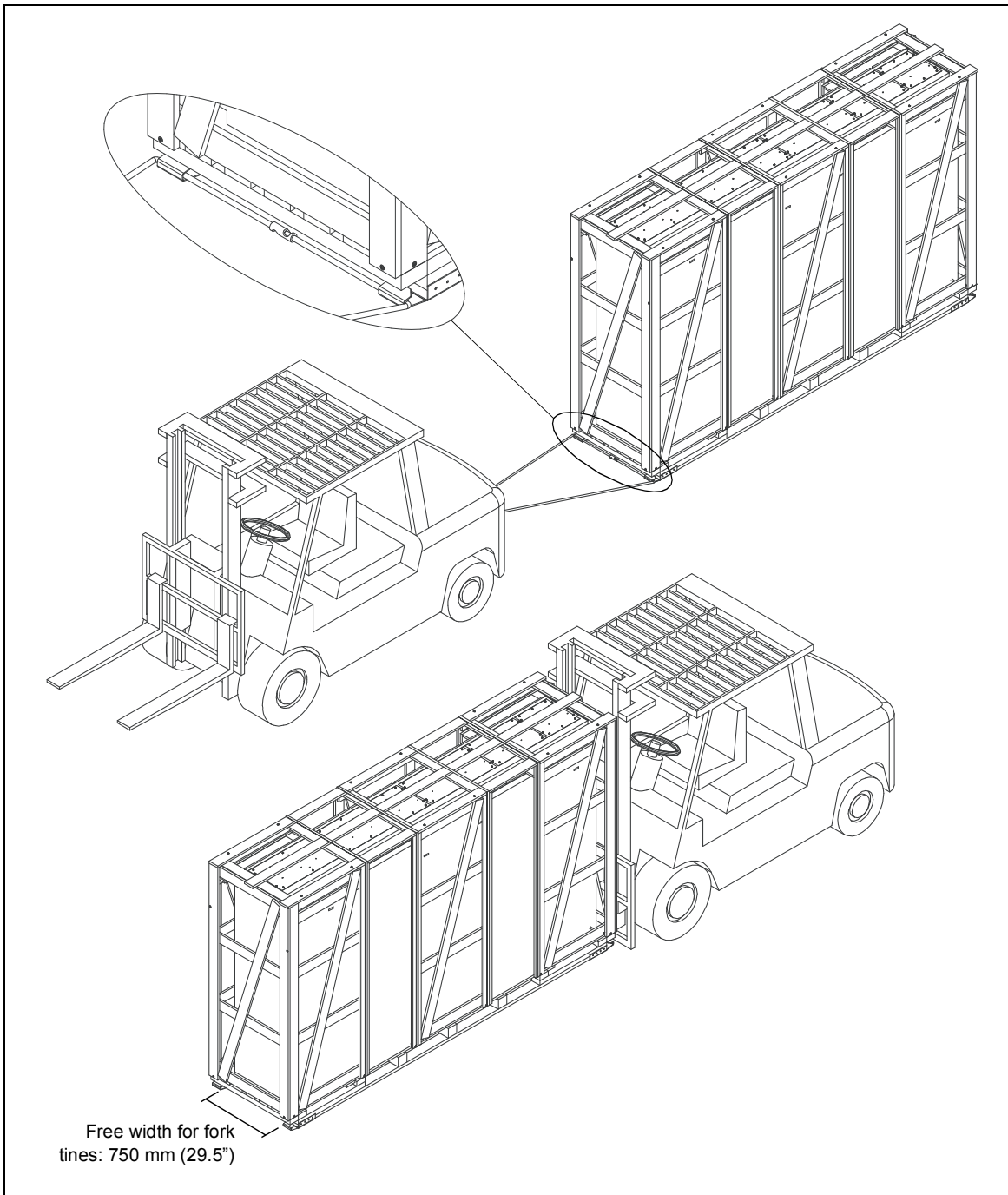

## ■ Removing the transport package

Remove the transport package as follows:

1. Undo the screws that attach the wooden parts of the transport crate together.
2. Remove the wooden parts.
3. Remove the clamps with which the drive cabinet is mounted onto the transport pallet by undoing the attaching screws.
4. Remove the plastic wrapping.

## ■ Moving the unpacked drive cabinet

### Lifting the cabinet with a crane

Lift the drive cabinet using its lifting eyes. The lifting eyes can be removed after the cabinet is in its final position, but their mounting holes must be blocked to retain the degree of protection.

**Note:** The minimum allowed height of the lifting slings with IP54 units is 2 meters (6'7").

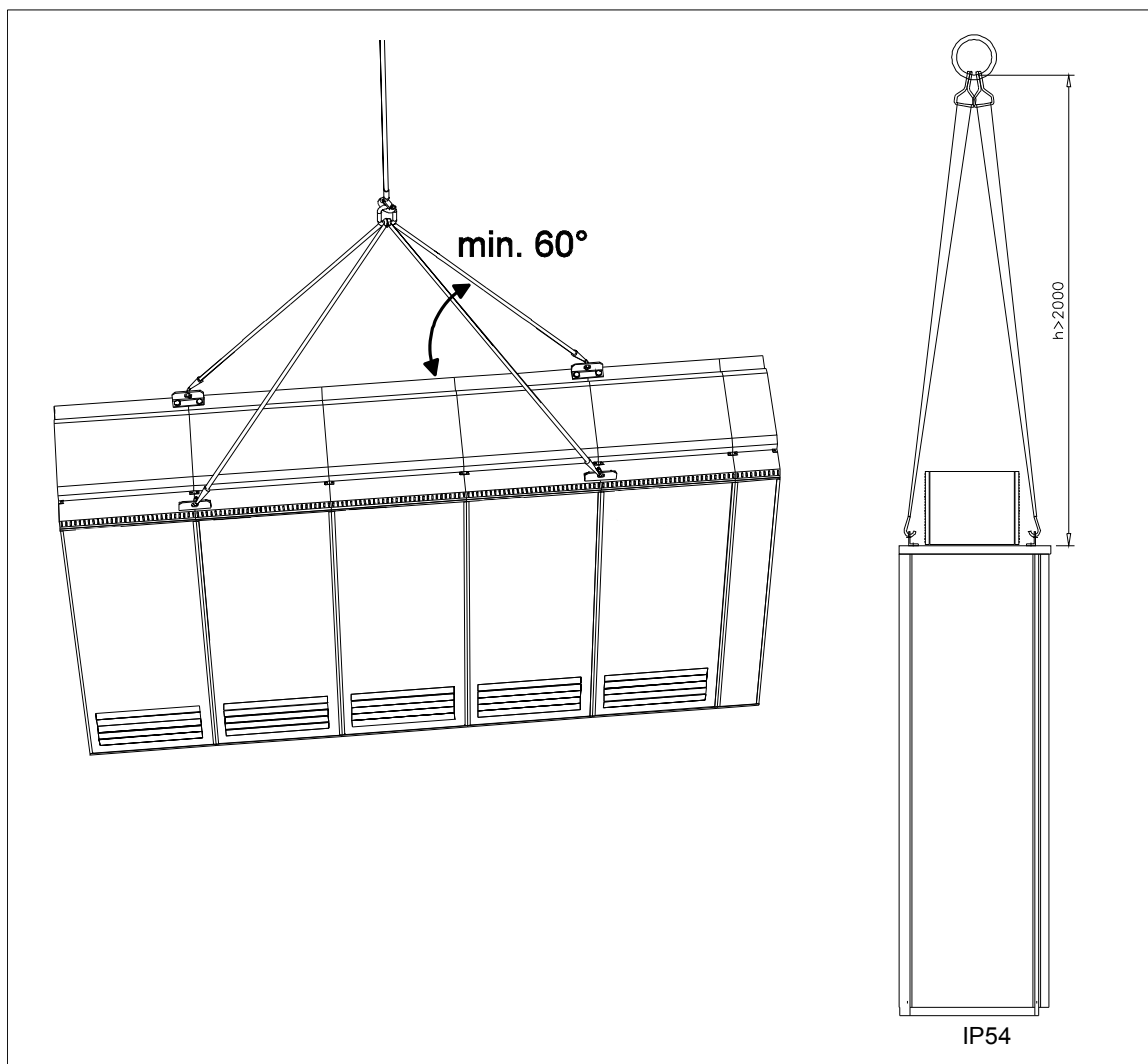

### Moving the cabinet on rollers



**WARNING:** Do not move marine versions (option +C121) on rollers.

Lay the cabinet on the rollers and move it carefully until close to its final location. Remove the rollers by lifting the unit with a crane, forklift, pallet truck or jack.

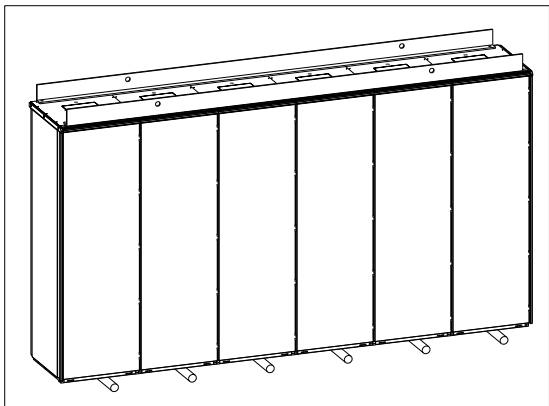

### Moving the cabinet on its back



**WARNING:** Transportation of the cabinet on its back is only allowed if it is packed for such transportation at the factory. Transportation of the cabinet on its back is only allowed with the sine filters (option +E206) removed from the cabinet.

Transportation of the R11 cabinet on its back is only allowed with the drive and LCL filter modules also removed from the cabinet.

If the cabinet needs to be laid on its back, support the cabinet from below alongside the cubicle seams.

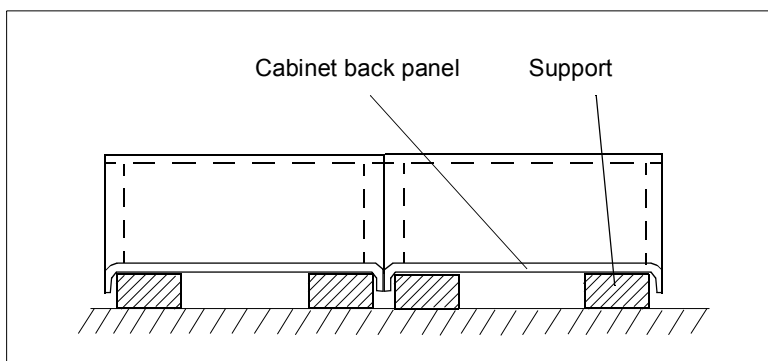



### Final placement of the cabinet

Move the cabinet into its final position with a slate bar (spud bar). Place a piece of wood between the edge of the cabinet and the bar to protect the cabinet frame.

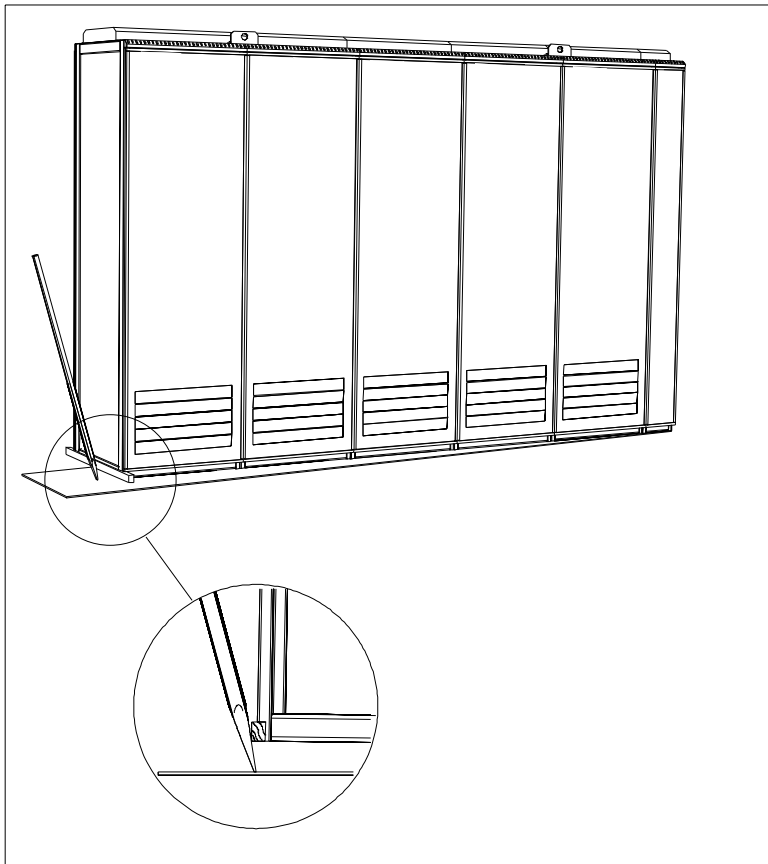

## Installing the IP54 roof (option +B055)

If the roof of an IP54 cabinet is delivered in a separate package, install the roof as follows.

### ■ Frame R8

1. Undo the lifting eye screws and remove the lifting eyes. See step 1 in section [Frame R11](#) on page 75.
2. To remove the top front profile of the cabinet, undo the mounting screws. Undo the back mounting screws. See step 2 in section [Frame R11](#) on page 75.
3. Remove the IP54 filter grating and connect the fan power supply wires.

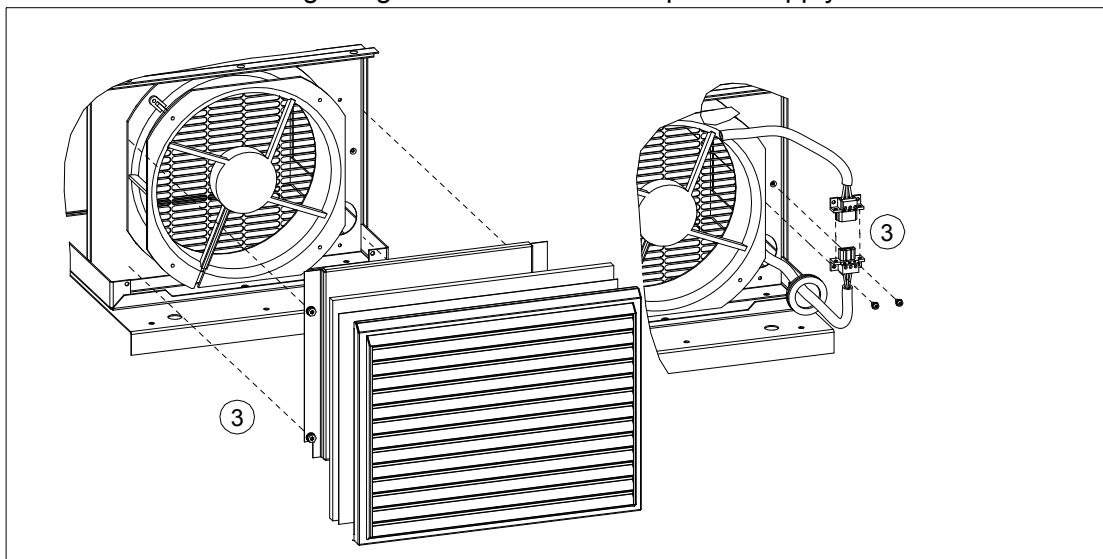

4. Install the front top profile of the cabinet in reverse order to step 2.
5. Attach the back mounting screws of the roof.
6. Install the IP54 filter grating.
7. Reinstall the mounting screws of the lifting eyes.



■ **Frame R11**

1. Undo the lifting eye screws and remove the lifting eyes.
2. To remove the top front profile of the cabinet, undo the mounting screws. Undo the back mounting screws.
3. Install the roof.
4. Connect the power supply wires to the fan.
5. Reinstall the front top profile of the cabinet in reverse order to step 2.
6. Install the back mounting screws of the roof.
7. Reinstall the mounting screws of the lifting eyes.

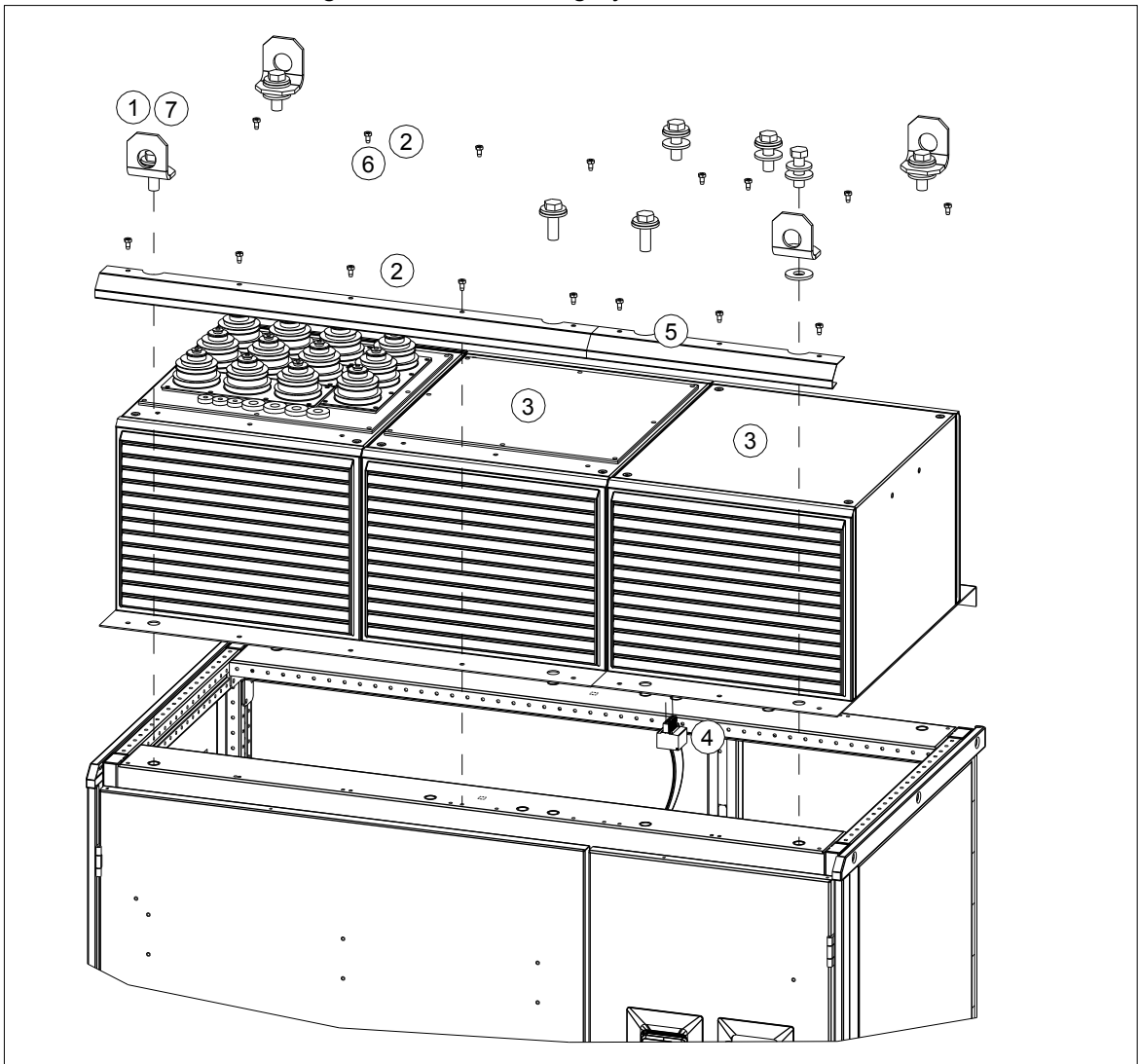

## Attaching the cabinet to the floor and wall or roof

### General rules

- The drive must be installed in an upright vertical position.
- The cabinet can be installed with its back against a wall (a), or back-to-back with another unit (b).
- Leave 400 mm (15.75") of free space above the basic roof level of the cabinet for cooling.
- Leave some space (w) at the side where the cabinet outmost hinges are to allow the doors to open sufficiently. The doors must open 120° to allow drive and LCL filter module replacement.

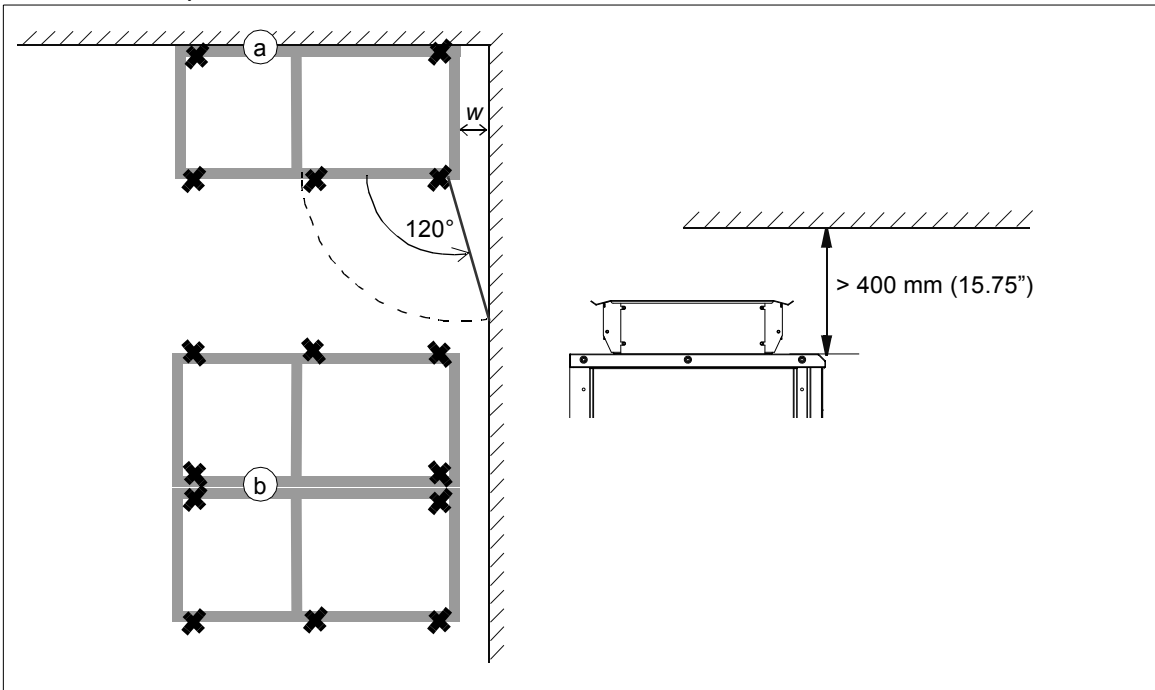

**Note 1:** Any height adjustment must be done before attaching the units or shipping splits together. Height adjustment can be done by using metal shims between the cabinet bottom and floor.

**Note 2:** If the lifting eyes are removed, reattach the bolts with the sealing rings delivered with the drive to retain the degree of protection of the cabinet. Drive cabinets with lifting bars: Remove the lifting bars. Reattach the bolts with the sealing rings delivered with the drive to retain the degree of protection of the cabinet. Tighten the bolt to a torque of 70 N·m (52 lb·ft).

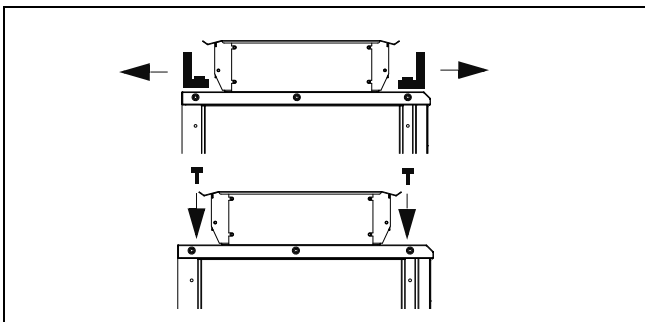

## ■ Attaching methods

Attach the cabinet to the floor by using clamps along the edge of the cabinet bottom, or by bolting the cabinet to the floor through the holes inside (if they are accessible).

### Alternative 1 – Clamping

	<ol style="list-style-type: none"> <li>1. Insert the clamps into the twin slots along the front and rear edges of the cabinet frame body and attach them to the floor with a bolt. The recommended maximum distance between the clamps in the front edge is 800 mm (31.5”).</li> <li>2. If floor mounting at the back is not possible, attach the top of the cabinet to the wall with L-brackets (not included in the delivery) bolted to the lifting eye holes.</li> </ol>
<p style="text-align: center;">Clamp dimensions</p>	



### Alternative 2 – Using the holes inside the cabinet

	<ol style="list-style-type: none"> <li>1. Attach the cabinet to the floor through the bottom attaching holes with M10 to M12 (3/8” to 1/2”) bolts. The recommended maximum distance between the front edge attaching points is 800 mm (31.5”).</li> <li>2. If the back attaching holes are not accessible, attach the cabinet at the top to wall with L-brackets (not included in the delivery) using the lifting eye holes.</li> </ol>

## Attaching the cabinet to the floor and wall or roof (marine units)

Obey the general rules given in section [General rules](#) on page 76.

See the dimension drawing delivered with the drive for the locations of the attaching holes in the flat bars below the cabinet and for attaching points at the top of the cabinet. Top attaching brackets are included in the delivery.

Attach the cabinet to the floor and roof (wall) as follows:

1. Bolt the unit to the floor through the holes in each flat bar at the base of the cabinet using M10 or M12 screws.
2. If there is not enough room behind the cabinet for installation, clamp the rear ends of the flat bars to the floor.
3. Remove the lifting eyes and bolt the attaching brackets into the lifting eye holes. Attach the top of the cabinet to the rear wall and/or roof with brackets.

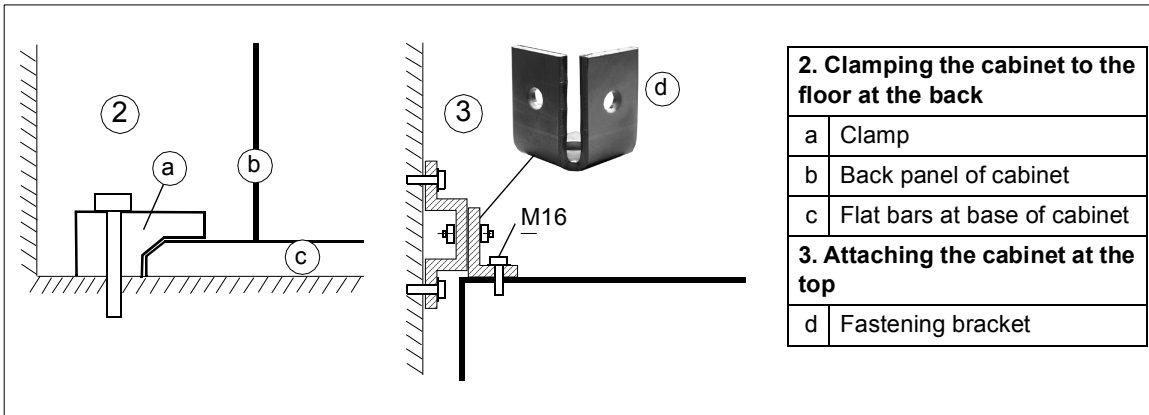

## Miscellaneous

### ■ Cable duct in the floor below the cabinet

A cable duct can be constructed below the 500 mm wide middle part of the cabinet. The cabinet weight lies on the two 50 mm wide transverse sections which the floor must carry.

Prevent the cooling air flow from the cable duct to the cabinet by bottom plates. To ensure the degree of protection for the cabinet, use the original bottom plates delivered with the unit. With user-defined cable entries, take care of the degree of protection, fire protection and EMC compliance.

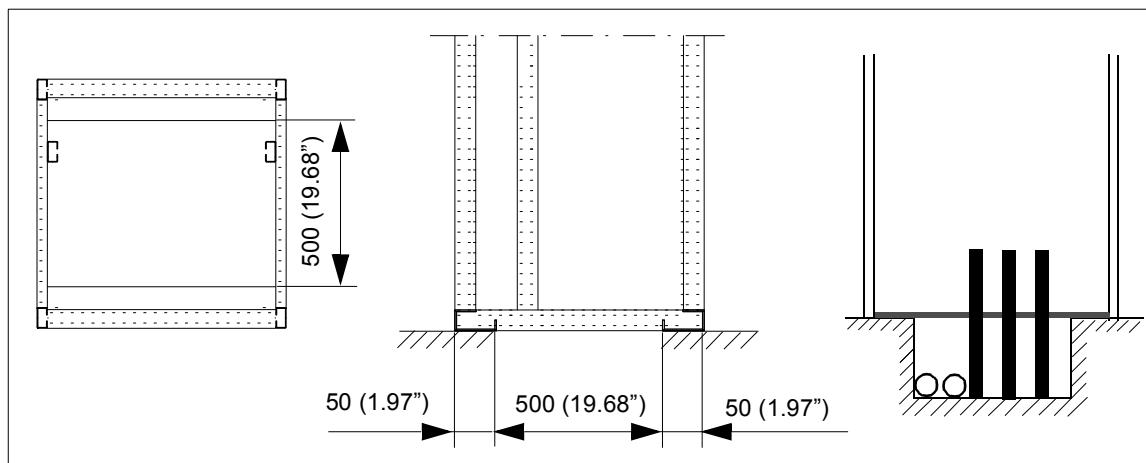

### ■ Air inlet through the bottom (option +C128)

Drives with air intake through the bottom of the cabinet (option +C128) are intended for installation on an air duct in the floor. Option +C128 requires also option +B055. An example of the required air inlets in the floor is shown in the dimension drawing on page 251. Refer also to the dimension drawings delivered with the drive.

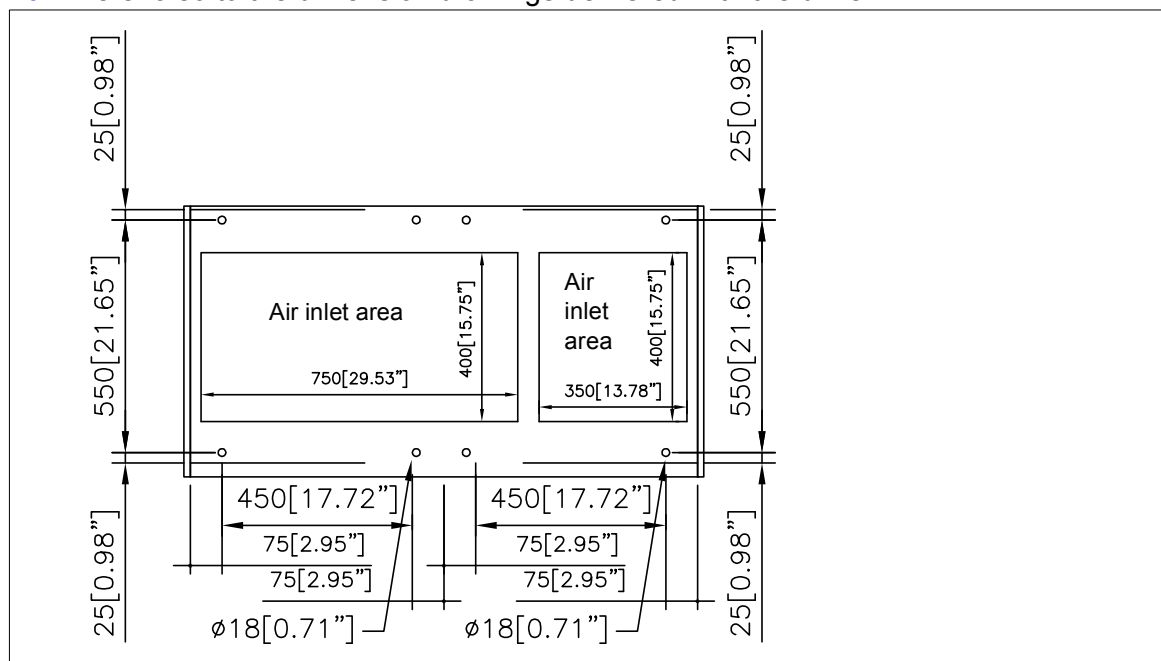

Support the plinth of the cabinet all round.

The air duct must be able to supply a sufficient volume of cooling air. The minimum air flow values are given in section [Cooling data, noise](#) on page 228.





**WARNING!** Make sure that the incoming air is sufficiently clean. If not, dust goes into the cabinet. The outlet filter on the cabinet roof prevents dust from going out. The collected dust can cause drive malfunction and danger of fire.

### Air outlet duct on the cabinet roof (option +C130)

The ventilation system must keep the static pressure in the air outlet duct sufficiently below the pressure of the room where the drive is located in order that the cabinet fans can produce the required air flow through the cabinet. Make sure that no dirty or moist air is able to flow backward to the drive in any case, even during off-time or while servicing the drive or the ventilation system.

#### Calculating the required static pressure difference

The required static pressure difference between the exit air duct and the drive installation room can be calculated as follows:

$$\Delta p_s = (1.5 \dots 2) \cdot p_d$$

where

$$p_d = 0.5 \cdot \rho \cdot v_m^2$$

$$v_m = q / A_c$$

$p_d$   $\hat{=}$  Dynamic pressure

$\rho$   $\hat{=}$  Air density (kg/m<sup>3</sup>), normally 1.1 kg/m<sup>3</sup>

$v_m$   $\hat{=}$  Average air velocity in the exit duct(s) (m/s)

$q$   $\hat{=}$  Rated air flow of the drive (m<sup>3</sup>/s)

$A_c$   $\hat{=}$  Cross-sectional area of the exit duct(s) (m<sup>2</sup>)

#### Example

The cabinet has 3 exit openings of 315 mm diameter. The rated air flow of the cabinet is 4650 m<sup>3</sup>/h = 1.3 m<sup>3</sup>/s.

$$A_c = 3 \cdot 0.315^2 \cdot \pi / 4 = 0.234 \text{ m}^2$$

$$v_m = q / A_c = 1.3 / 0.234 = 5.5 \text{ m/s}$$

$$p_d = 0.5 \cdot \rho \cdot v_m^2 = 0.5 \cdot 1.1 \cdot 5.5^2 = 17 \text{ Pa}$$

The required pressure in the exit air duct is then, 1.5...2 • 17 Pa = 26...34 Pa, below the pressure in the room.

For more information, contact ABB.

### Arc welding

Attaching the cabinet by arc welding is not recommended. However, if arc welding is the only mounting option, connect the return conductor of the welding equipment to the cabinet frame at the bottom within 0.5 meters (1'6") of the welding point.

**Note:** The thickness of the zinc coating of the cabinet frame is 100...200 micrometers (3.94...7.87 mil).





**WARNING!** Make sure that the return wire is connected correctly. Welding current must not return via any component or cabling of the drive. If the welding return wire is connected improperly, the welding circuit can damage electronic circuits in the cabinet.

---



**WARNING!** Do not inhale the welding fumes.

---





# 5

## Guidelines for planning the electrical installation

---

### Contents of this chapter

This chapter contains instructions for planning the electrical installation of the drive. Some instructions are mandatory to follow in every installation, others provide useful information that only concerns certain applications.

### Limitation of liability

The installation must always be designed and made according to applicable local laws and regulations. ABB does not assume any liability whatsoever for any installation which breaches the local laws and/or other regulations. Furthermore, if the recommendations given by ABB are not followed, the drive may experience problems that the warranty does not cover.

### Selecting the supply disconnecting device

The drive is equipped with a main disconnecting device. The disconnecting device can be locked to the open position for installation and maintenance work.

### Examining the compatibility of the motor and drive

Use an asynchronous AC induction motor, permanent magnet synchronous motor, AC induction servomotor or ABB synchronous reluctance (SynRM) motor with the drive. Several induction motors can be connected to the drive at a time but only one permanent magnet motor.

---

Select the motor size and drive type from the rating tables in chapter [Technical data](#) on basis of the AC line voltage and motor load. Use the DriveSize PC tool if you need to tune the selection more in detail.

Make sure that the motor withstands the maximum peak voltage in the motor terminals. See the [Requirements table](#) on page 85. For basics of protecting the motor insulation and bearings in drive systems, refer to section [Protecting the motor insulation and bearings](#) below.

**Note:**

- Consult the motor manufacturer before using a motor whose nominal voltage differs from the AC line voltage connected to the drive input.
- The voltage peaks at the motor terminals are relative to the supply voltage of the drive, not the drive output voltage.
- If the motor and drive are not of the same size, consider the following operation limits of the drive control program:
  - motor nominal voltage range  $1/6 \dots 2 \cdot U_N$
  - motor nominal current range  $1/6 \dots 2 \cdot I_N$  of the drive in DTC control and  $0 \dots 2 \cdot I_N$  in scalar control. The control mode is selected by a drive parameter.

### ■ Protecting the motor insulation and bearings

The drive employs modern IGBT inverter technology. Regardless of frequency, the drive output comprises pulses of approximately the drive DC bus voltage with a very short rise time. The pulse voltage can almost double at the motor terminals, depending on the attenuation and reflection properties of the motor cable and the terminals. This can cause additional stress on the motor and motor cable insulation.

Modern variable speed drives with their fast rising voltage pulses and high switching frequencies can generate current pulses that flow through the motor bearings. This can gradually erode the bearing races and rolling elements.

Optional du/dt filters protect motor insulation system and reduce bearing currents. Optional common mode filters mainly reduce bearing currents. Insulated N-end (non-drive end) bearings protect the motor bearings.

---

## ■ Requirements table

The following table shows how to select the motor insulation system and when an optional drive du/dt and common mode filters and insulated N-end (non-drive end) motor bearings are required. Ignoring the requirements or improper installation may shorten motor life or damage the motor bearings and voids the warranty.

Motor type	Nominal AC supply voltage	Requirement for		
		Motor insulation system	ABB du/dt and common mode filters, insulated N-end motor bearings	
			100 kW ≤ P <sub>N</sub> < 350 kW or IEC 315 ≤ frame size < IEC 400	P <sub>N</sub> ≥ 350 kW or frame size ≥ IEC 400
		134 hp ≤ P <sub>N</sub> < 469 hp or NEMA 500 ≤ frame size ≤ NEMA 580	P <sub>N</sub> ≥ 469 hp or frame size > NEMA 580	
<b>ABB motors</b>				
Random-wound M2_, M3_ and M4_	U <sub>N</sub> ≤ 500 V	Standard	+ N	+ N + CMF
	500 V < U <sub>N</sub> ≤ 600 V	Standard	+ N + du/dt	+ N + du/dt + CMF
		or		
		Reinforced	+ N	+ N + CMF
	600 V < U <sub>N</sub> ≤ 690 V (cable length ≤ 150 m)	Reinforced	+ N + du/dt	+ N + du/dt + CMF
600 V < U <sub>N</sub> ≤ 690 V (cable length > 150 m)	Reinforced	+ N	+ N + CMF	
Form-wound HX_ and AM_	380 V < U <sub>N</sub> ≤ 690 V	Standard	+ N + CMF	P <sub>N</sub> < 500 kW: +N + CMF
				P <sub>N</sub> ≥ 500 kW +N + du/dt + CMF
Old* form-wound HX_ and modular	380 V < U <sub>N</sub> ≤ 690 V	Check with the motor manufacturer.	+ N + du/dt with voltages over 500 V + CMF	
Random-wound HX_ and AM_**	0 V < U <sub>N</sub> ≤ 500 V	Enamelled wire with fiber glass taping	+ N + CMF	
	500 V < U <sub>N</sub> ≤ 690 V		+ N + du/dt + CMF	
HDP	Consult the motor manufacturer.			

\* manufactured before 1.1.1998

\*\* For motors manufactured before 1.1.1998, check for additional instructions with the motor manufacturer.

Motor type	Nominal AC supply voltage	Requirement for		
		Motor insulation system	ABB du/dt and common mode filters, insulated N-end motor bearings	
			$100 \text{ kW} \leq P_N < 350 \text{ kW}$ or $\text{IEC } 315 \leq \text{frame size} < \text{IEC } 400$	$P_N \geq 350 \text{ kW}$ or $\text{frame size} \geq \text{IEC } 400$
			$134 \text{ hp} \leq P_N < 469 \text{ hp}$ or $\text{NEMA } 500 \leq \text{frame size} \leq \text{NEMA } 580$	$P_N \geq 469 \text{ hp}$ or $\text{frame size} > \text{NEMA } 580$
<b>Non-ABB motors</b>				
Random-wound and form-wound	$U_N \leq 420 \text{ V}$	Standard: $\dot{U}_{LL} = 1300 \text{ V}$	+ N or CMF	+ N + CMF
	$420 \text{ V} < U_N \leq 500 \text{ V}$	Standard: $\dot{U}_{LL} = 1300 \text{ V}$	+ du/dt + (N or CMF)	+ N + du/dt + CMF
		or		
	$500 \text{ V} < U_N \leq 600 \text{ V}$	Reinforced: $\dot{U}_{LL} = 1600 \text{ V}$ , 0.2 microsecond rise time	+ N or CMF	+ N + CMF
		Reinforced: $\dot{U}_{LL} = 1600 \text{ V}$	+ du/dt + (N or CMF)	+ N + du/dt + CMF
		or		
	$600 \text{ V} < U_N \leq 690 \text{ V}$	Reinforced: $\dot{U}_{LL} = 1800 \text{ V}$	+ N or CMF	+ N + CMF
		Reinforced: $\dot{U}_{LL} = 1800 \text{ V}$	+ du/dt + N	+ N + du/dt + CMF
$600 \text{ V} < U_N \leq 690 \text{ V}$	Reinforced: $\dot{U}_{LL} = 2000 \text{ V}$ , 0.3 microsecond rise time ***	N + CMF	+ N + CMF	

\*\*\* If the intermediate DC circuit voltage of the drive is increased from the nominal level by resistor braking or by the IGBT supply unit control program (parameter selectable function), check with the motor manufacturer if additional output filters are needed in the applied drive operation range.

The abbreviations used in the table are defined below.

Abbr.	Definition
$U_N$	Nominal AC line voltage
$\dot{U}_{LL}$	Peak line-to-line voltage at motor terminals which the motor insulation must withstand
$P_N$	Motor nominal power
du/dt	du/dt filter at the output of the drive (standard equipment)
CMF	Common mode filter (standard equipment)
N	N-end bearing: insulated motor non-drive end bearing
n.a.	Motors of this power range are not available as standard units. Consult the motor manufacturer.

### Additional requirements for explosion-safe (EX) motors

If you will use an explosion-safe (EX) motor, follow the rules in the requirements table above. In addition, consult the motor manufacturer for any further requirements.

### Additional requirements for ABB motors of types other than M2\_, M3\_, M4\_, HX\_ and AM\_

Use the selection criteria given for non-ABB motors.

### Additional requirements for the regenerative and low harmonic drives

It is possible to increase the intermediate circuit DC voltage from the nominal standard level with a parameter in the control program. If you choose to do this, select the motor insulation system to withstand to the increased DC voltage level.

### Additional requirements for braking applications

When the motor brakes the machinery, the intermediate circuit DC voltage of the drive increases, the effect being similar to increasing the motor supply voltage by up to 20 percent. Consider this voltage increase when specifying the motor insulation requirements if the motor will be braking a large part of its operation time.

Example: Motor insulation requirement for a 400 V AC line voltage application must be selected as if the drive were supplied with 480 V.

### Additional requirements for ABB high-output and IP23 motors

The rated output power of high output motors is higher than what is stated for the particular frame size in EN 50347 (2001). This table shows the requirements for ABB random-wound motor series (for example, M3AA, M3AP and M3BP).

Nominal AC supply voltage	Requirement for		
	Motor insulation system	ABB du/dt and common mode filters, insulated N-end motor bearings	
		$100 \text{ kW} \leq P_N < 200 \text{ kW}$ $140 \text{ hp} \leq P_N < 268 \text{ hp}$	$P_N \geq 200 \text{ kW}$ $P_N \geq 268 \text{ hp}$
$U_N \leq 500 \text{ V}$	Standard	+ N	+ N + CMF
$500 \text{ V} < U_N \leq 600 \text{ V}$	Standard	+ N + du/dt	+ N + du/dt + CMF
	or		
	Reinforced	+ N	+ N + CMF
$600 \text{ V} < U_N \leq 690 \text{ V}$	Reinforced	+ N + du/dt	+ N + du/dt + CMF

### Additional requirements for non-ABB high-output and IP23 motors

The rated output power of high-output motors is higher than what is stated for the particular frame size in EN 50347 (2001). The table below shows the requirements for random-wound and form-wound non-ABB motors with nominal power smaller than 350 kW. For bigger motors, consult the motor manufacturer.

Nominal AC line voltage	Requirement for	
	Motor insulation system	ABB du/dt filter, insulated N-end bearing and ABB common mode filter
		$100 \text{ kW} \leq P_N < 350 \text{ kW}$ or $\text{IEC } 315 \leq \text{frame size} < \text{IEC } 400$ $134 \text{ hp} \leq P_N < 469 \text{ hp}$ or $\text{NEMA } 500 \leq \text{frame size} \leq \text{NEMA } 580$
$U_N \leq 420 \text{ V}$	Standard: $\hat{U}_{LL} = 1300 \text{ V}$	+ N + CMF

Nominal AC line voltage	Requirement for	
	Motor insulation system	ABB du/dt filter, insulated N-end bearing and ABB common mode filter
		100 kW $\leq P_N < 350$ kW or IEC 315 $\leq$ frame size $<$ IEC 400
420 V $< U_N \leq 500$ V	Standard: $\hat{U}_{LL} = 1300$ V	+ N + du/dt + CMF
	or	
	Reinforced: $\hat{U}_{LL} = 1600$ V, 0.2 microsecond rise time	+ N + CMF
500 V $< U_N \leq 600$ V	Reinforced: $\hat{U}_{LL} = 1600$ V	+ N + du/dt + CMF
	or	
	Reinforced: $\hat{U}_{LL} = 1800$ V	+ N + CMF
600 V $< U_N \leq 690$ V	Reinforced: $\hat{U}_{LL} = 1800$ V	+ N + du/dt + CMF
	Reinforced: $\hat{U}_{LL} = 2000$ V, 0.3 microsecond rise time ***	+ N + CMF

\*\*\* If the intermediate DC circuit voltage of the drive is increased from the nominal level by resistor braking, check with the motor manufacturer if additional output filters are needed in the applied drive operation range.



### Additional data for calculating the rise time and the peak line-to-line voltage

If you need to calculate the actual peak voltage and voltage rise time considering the actual cable length, proceed as follows:

- Peak line-to line voltage: Read the relative  $\hat{U}_{LL}/U_N$  value from the diagram below and multiply it by the nominal supply voltage ( $U_N$ ).
- Voltage rise time: Read the relative values  $\hat{U}_{LL}/U_N$  and  $(du/dt)/U_N$  from the diagram below. Multiply the values by the nominal supply voltage ( $U_N$ ) and substitute into equation  $t = 0.8 \cdot \hat{U}_{LL}/(du/dt)$ .

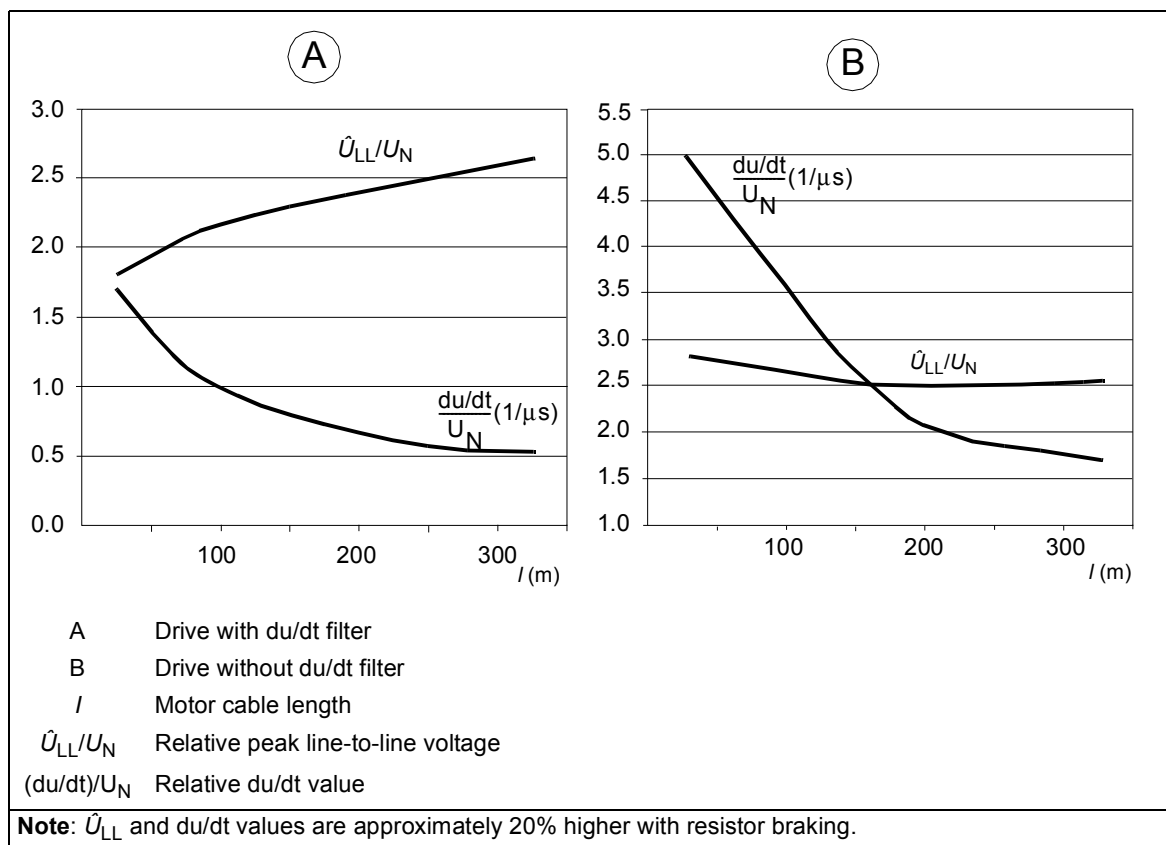

### Additional note for sine filters (option +E206)

Sine filters protect the motor insulation system. Therefore, du/dt filter can be replaced with a sine filter. The peak phase-to-phase voltage with the sine filter is approximately  $1.5 \cdot U_N$ .

## Selecting the power cables

### ■ General rules

Select the input power and motor cables according to local regulations:

- Select a cable capable of carrying the drive nominal current. See section [Ratings](#) (page 217) for the rated currents, and section [Typical cable sizes](#) (page 91) for typical cable sizes.
- Select a cable rated for at least 70 °C maximum permissible temperature of conductor in continuous use. For US, see [Additional US requirements](#), page 93.
- The inductance and impedance of the PE conductor/cable (grounding wire) must be rated according to permissible touch voltage appearing under fault conditions (so that the fault point voltage will not rise excessively when a ground fault occurs).
- 600 V AC cable is accepted for up to 500 V AC. 750 V AC cable is accepted for up to 600 V AC. For 690 V AC rated equipment, the rated voltage between the conductors of the cable should be at least 1 kV.

Use symmetrical shielded motor cable (see page 92). Ground motor cable shields 360° at both ends. Keep the motor cable and its PE pigtail (twisted shield) as short as possible to reduce high-frequency electromagnetic emissions.

**Note:** When continuous metal conduit is employed, shielded cable is not required. The conduit must have bonding at both ends.

A four-conductor system is allowed for input cabling with restrictions, but shielded symmetrical cable is recommended.

Compared to a four-conductor system, the use of symmetrical shielded cable reduces electromagnetic emission of the whole drive system as well as the stress on motor insulation, bearing currents and wear.

The protective conductor must always have an adequate conductivity.

Unless local wiring regulations state otherwise, the cross-sectional area of the protective conductor must agree with the conditions that require automatic disconnection of the supply required in 411.3.2. of IEC 60364-4-41:2005 and be capable of withstanding the prospective fault current during the disconnection time of the protective device.

The cross-sectional area of the protective conductor can either be selected from the table below or calculated according to 543.1 of IEC 60364-5-54.

---

This table shows the minimum cross-sectional area related to the phase conductor size according to IEC 61800-5-1 when the phase conductor and the protective conductor are made of the same metal. If this is not so, the cross-sectional area of the protective earthing conductor shall be determined in a manner which produces a conductance equivalent to that which results from the application of this table.

Cross-sectional area of the phase conductors $S$ (mm <sup>2</sup> )	Minimum cross-sectional area of the corresponding protective conductor $S_p$ (mm <sup>2</sup> )
$S \leq 16$	$S$
$16 < S \leq 35$	16
$35 < S$	$S/2$

### ■ Typical cable sizes

The table below gives copper and aluminum cable types with concentric copper shield for nominal current. For drawings of the terminals, see chapter *Dimensions* (page 243).

Drive type ACS880-37-	Frame size	IEC <sup>1)</sup>		UL <sup>2)</sup>
		Cu cable size	Al cable size	Cu cable size
		mm <sup>2</sup>	mm <sup>2</sup>	AWG/kcmil
<b><math>U_N = 400</math> V</b>				
0105A-3	R8	3×50	3×70	1
0145A-3	R8	3×95	3×120	2/0
0169A-3	R8	3×120	3×150	3/0
0206A-3	R8	3×150	3×240	250 MCM
0293A-3	R11	2 × (3×95)	2 × (3×120)	2 × 3/0
0363A-3	R11	2 × (3×120)	2 × (3×185)	2 × 4/0
0442A-3	R11	2 × (3×150)	3 × (3×120)	2 × 250
0505A-3	R11	3 × (3×95)	3 × (3×150)	2×500 MCM or 3×250 MCM
0585A-3	R11	3 × (3×120)	3 × (3×185)	2×600 MCM or 3×300 MCM
0650A-3	R11	3 × (3×150)	3 × (3×240)	2×700 MCM or 3×350 MCM
<b><math>U_N = 500</math> V</b>				
0101A-5	R8	3×50	3×70	1
0124A-5	R8	3×95	3×95	2/0
0156A-5	R8	3×120	3×150	3/0
0180A-5	R8	3×150	3×185	250 MCM
0260A-5	R11	2 × (3×70)	2 × (3×95)	2 × 2/0
0361A-5	R11	2 × (3×120)	2 × (3×185)	2 × 250 MCM
0414A-5	R11	2 × (3×150)	2 × (3×240)	2 × 250 MCM
0460A-5	R11	2 × (3×185)	3 × (3×120)	2×400 MCM or 3×4/0
0503A-5	R11	3 × (3×95)	3 × (3×150)	2×500 MCM or 3×250 MCM
<b><math>U_N = 690</math> V</b>				
0174A-7	R11	3×120	2 × (3×70)	4/0
0210A-7	R11	3×185	2 × (3×95)	300 MCM
0271A-7	R11	3×240	2 × (3×120)	400 MCM
0330A-7	R11	2 × (3×95)	2 × (3×150)	2 × 250 MCM or 3×2/0
0370A-7	R11	2 × (3×120)	2 × (3×150)	2 × 300 MCM or 3×3/0
0430A-7	R11	2 × (3×185)	3 × (3×120)	2 × 350 MCM or 3×4/0

## 92 Guidelines for planning the electrical installation

1. The cable sizing is based on max. 9 cables laid on a cable ladder side by side, three ladder type trays one on top of the other, ambient temperature 30 °C, PVC insulation, surface temperature 70 °C (EN 60204-1 and IEC 60364-5-52/2001). For other conditions, size the cables according to local safety regulations, appropriate input voltage and the load current of the drive.
2. The cable sizing is based on NEC Table 310-16 for copper wires, 75 °C (167 °F) wire insulation at 40 °C (104 °F) ambient temperature. Not more than three current-carrying conductors in raceway or cable or earth (directly buried). For other conditions, size the cables according to local safety regulations, appropriate input voltage and the load current of the drive.



### Alternative power cable types

The recommended and not allowed power cable types to be used with the drive are presented below.

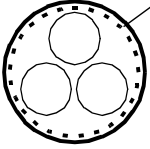
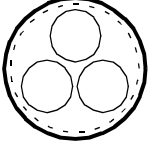
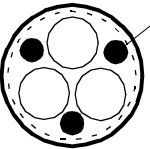
#### Recommended power cable types

	<p>Symmetrical shielded cable with three phase conductors and a concentric PE conductor as shield. The shield must meet the requirements of IEC 61800-5-1, see page 90. Check with local / state / country electrical codes for allowance.</p>
	<p>Symmetrical shielded cable with three phase conductors and a concentric PE conductor as shield. A separate PE conductor is required if the shield does not meet the requirements of IEC 61800-5-1, see page 90.</p>
	<p>Symmetrical shielded cable with three phase conductors and symmetrically constructed PE conductor, and a shield. The PE conductor must meet the requirements of IEC 61800-5-1.</p>

#### Power cable types for limited use

	<p>A four-conductor system consisting of unshielded single-core phase conductors and a protective conductor on a cable tray) is <b>not allowed for input cabling on IT (ungrounded) networks.</b></p> <p> <b>WARNING!</b> Do not use unshielded single-core cables with drives on IT (ungrounded) networks. A dangerous voltage can become present on the non-conductive outer sheath of the cable. This can cause injury or death.</p> <p>A four-conductor system consisting of separate phase conductors (regardless of the presence of shielding) and a protective conductor on a cable tray is <b>not allowed for motor cabling.</b></p>
---	---

### Not allowed power cable types

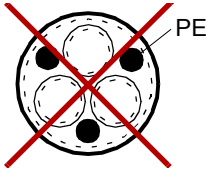
	<p>Symmetrical shielded cable with individual shields for each phase conductor is <b>not allowed on any cable size for input and motor cabling</b>.</p>
---	---

### ■ Motor cable shield

If the motor cable shield is used as the sole protective earth conductor of the motor, make sure that the conductivity of the shield is sufficient. See section [General rules](#) on page 90, or IEC 61800-5-1. To effectively suppress radiated and conducted radio-frequency emissions, the cable shield conductivity must be at least 1/10 of the phase conductor conductivity. The requirements are easily met with a copper or aluminum shield. The minimum requirement of the motor cable shield of the drive is shown below. It consists of a concentric layer of copper wires with an open helix of copper tape or copper wire. The better and tighter the shield, the lower the emission level and bearing currents.

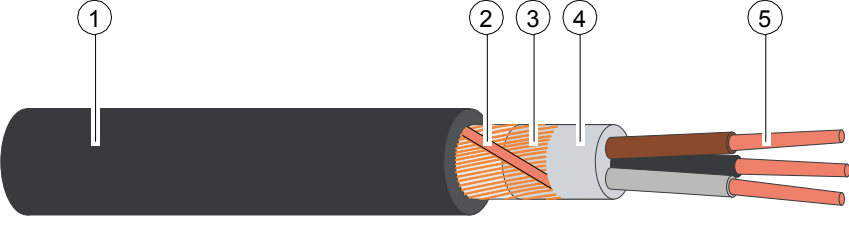

1	Insulation jacket
2	Helix of copper tape or copper wire
3	Copper wire screen
4	Inner insulation
5	Cable core

### ■ Additional US requirements

Use type MC continuous corrugated aluminum armor cable with symmetrical grounds or shielded power cable for the motor cables if metallic conduit is not used. For the North American market, 600 V AC cable is accepted for up to 500 V AC. 1000 V AC cable is required above 500 V AC (below 600 V AC). For drives rated over 100 amperes, the power cables must be rated for 75 °C (167 °F).

#### Conduit

Couple separate parts of a conduit together: bridge the joints with a ground conductor bonded to the conduit on each side of the joint. Also bond the conduits to the drive enclosure and motor frame. Use separate conduits for input power, motor, brake resistor, and control wiring. When conduit is employed, type MC continuous corrugated aluminum armor cable or shielded cable is not required. A dedicated ground cable is always required.

**Note:** Do not run motor wiring from more than one drive in the same conduit.

### **Armored cable / shielded power cable**

Six conductor (3 phases and 3 ground) type MC continuous corrugated aluminum armor cable with symmetrical grounds is available from the following suppliers (trade names in parentheses):

- Anixter Wire & Cable (Philsheath)
- BICC General Corp (Philsheath)
- Rockbestos Co. (Gardex)
- Oaknite (CLX).

Shielded power cables are available from Belden, LAPPKABEL (ÖLFLEX) and Pirelli.

## **Planning the braking system**

See chapter [Resistor braking](#).

## Selecting the control cables

### ■ Shielding

All control cables must be shielded.

Use a double-shielded twisted pair cable for analog signals. This type of cable is recommended for the pulse encoder signals also. Employ one individually shielded pair for each signal. Do not use common return for different analog signals.

A double-shielded cable (figure a below) is the best alternative for low-voltage digital signals but single-shielded (b) twisted pair cable is also acceptable.

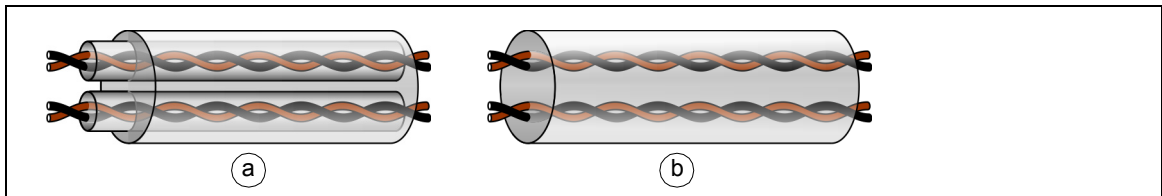

### ■ Signals in separate cables

Run analog and digital signals in separate, shielded cables. Never mix 24 V DC and 115/230 V AC signals in the same cable.

### ■ Signals allowed to be run in the same cable

Relay-controlled signals, providing their voltage does not exceed 48 V, can be run in the same cables as digital input signals. The relay-controlled signals should be run as twisted pairs.

### ■ Relay cable type

The cable type with braided metallic screen (for example ÖLFLEX by LAPPKABEL, Germany) has been tested and approved by ABB.

### ■ Control panel cable length and type

In remote use, the cable connecting the control panel to the drive must not be longer than three meters (10 ft). Cable type: shielded CAT 5e or better Ethernet patch cable with RJ-45 ends.

## Routing the cables

Route the motor cable away from other cable routes. Motor cables of several drives can be run in parallel installed next to each other. The motor cable, input power cable and control cables should be installed on separate trays. Avoid long parallel runs of motor cables with other cables in order to decrease electromagnetic interference caused by the rapid changes in the drive output voltage.

Where control cables must cross power cables, make sure they are arranged at an angle as near to 90 degrees as possible. Do not run extra cables through the drive.

The cable trays must have good electrical bonding to each other and to the grounding electrodes. Aluminum tray systems can be used to improve local equalizing of potential.

A diagram of the cable routing is shown below.

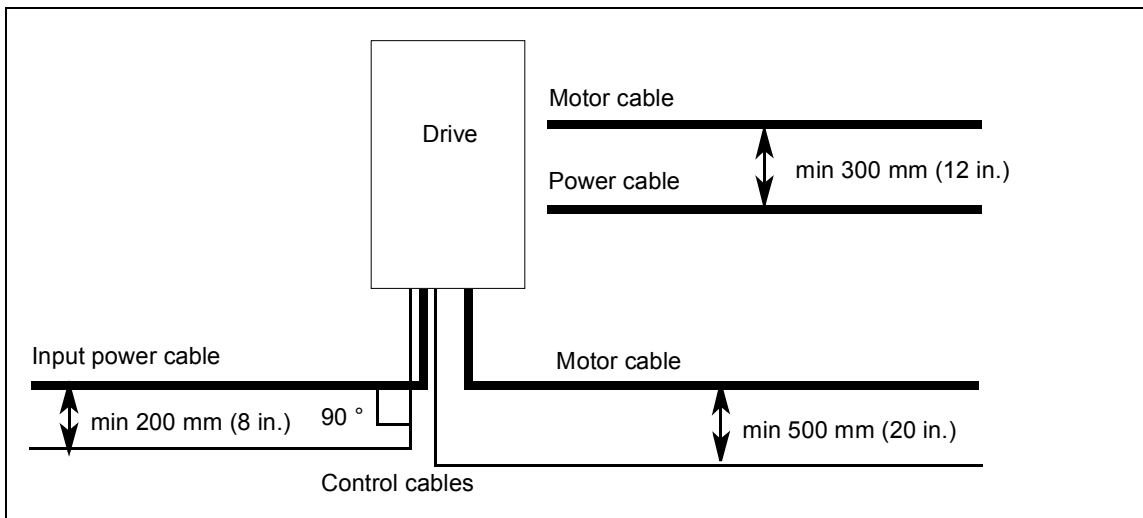

### ■ Separate control cable ducts

Lead 24 V and 230 V (120 V) control cables in separate ducts unless the 24 V cable is insulated for 230 V (120 V) or insulated with an insulation sleeving for 230 V (120 V).

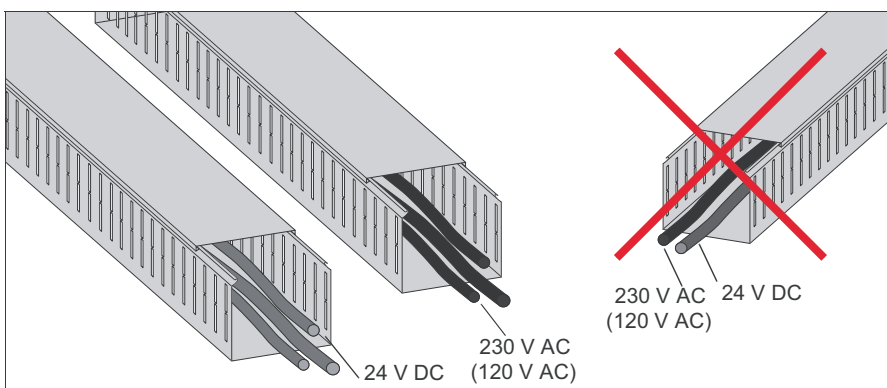



■ **Continuous motor cable shield or enclosure for equipment on the motor cable**

To minimize the emission level when safety switches, contactors, connection boxes or similar equipment are installed on the motor cable between the drive and the motor:

- European Union: Install the equipment in a metal enclosure with 360 degree grounding for the shields of both the incoming and outgoing cable, or connect the shields of the cables otherwise together.
- North America: Install the equipment in a metal enclosure in a way that the conduit or motor cable shielding runs consistently without breaks from the drive to the motor.

**Implementing thermal overload and short-circuit protection**

■ **Protecting the drive and input power cable in short-circuits**

The drive is equipped with internal AC fuses (1) as standard. The fuses restrict drive damage and prevent damage to adjoining equipment in case of a short-circuit inside the drive.

Protect the input cable with fuses or circuit breaker (2) according to local safety regulations, appropriate input voltage and the rated current of the drive (see chapter [Technical data](#)).

**R8**

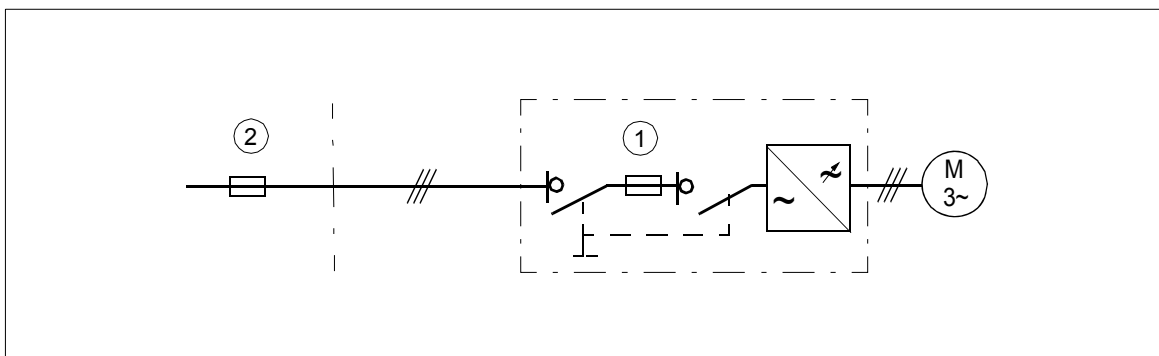

**R11**

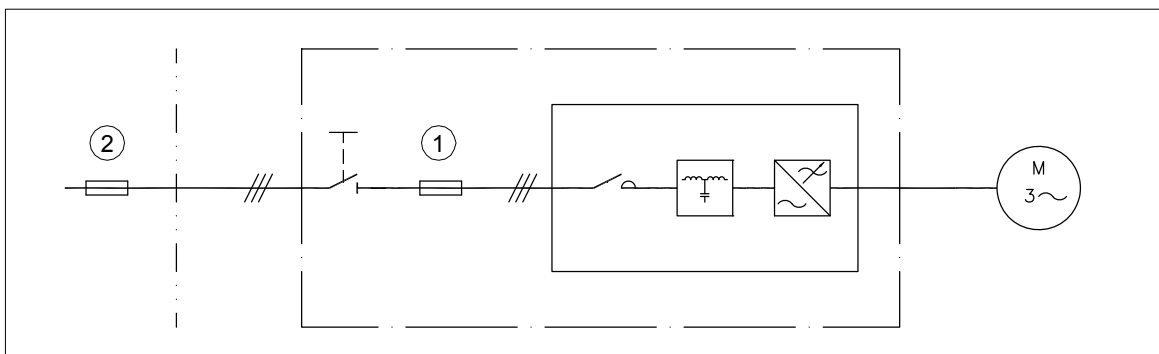

■ **Protecting the motor and motor cable in short-circuits**

The drive protects the motor cable and motor in a short-circuit situation when the motor cable is sized according to the nominal current of the drive. No additional protection devices are needed.

## ■ Protecting the drive and the power cables against thermal overload

The drive protects itself and the input and motor cables against thermal overload when the cables are sized according to the nominal current of the drive. No additional thermal protection devices are needed.



**WARNING!** If the drive is connected to multiple motors, use a separate circuit breaker or fuses for protecting each motor cable and motor against overload. The drive overload protection is tuned for the total motor load. It may not trip due to an overload in one motor circuit only.

---

## ■ Protecting the motor against thermal overload

According to regulations, the motor must be protected against thermal overload and the current must be switched off when overload is detected. The drive includes a motor thermal protection function that protects the motor and switches off the current when necessary. Depending on a drive parameter value, the function either monitors a calculated temperature value (based on a motor thermal model) or an actual temperature indication given by motor temperature sensors. The user can tune the thermal model further by feeding in additional motor and load data.

The most common temperature sensors are:

- motor sizes IEC180...225: thermal switch, eg. Klixon
- motor sizes IEC200...250 and larger: PTC or Pt100.

See the firmware manual for more information on the motor thermal protection, and the connection and use of the temperature sensors.

## Implementing a ground fault detection function

The drive has a function that detects ground faults in the motor and motor cable. The user can select how the drive reacts to a ground fault (parameter setting). Note that this function is not a personnel safety or a fire protection feature. See the firmware manual for more information.

An optional ground fault monitoring device (option +Q954) is available for IT (ungrounded) systems. The option includes a ground fault indicator on the drive cabinet door.

## ■ Residual current device compatibility

The drive is suitable to be used with residual current devices of Type B.

**Note:** The EMC filter of the drive includes capacitors connected between the main circuit and the frame. These capacitors and long motor cables increase the ground leakage current and may cause fault current circuit breakers to function.

## Implementing the emergency stop function

The drive can be equipped with a category 0 and 1 emergency stop function (option +Q951, +Q952, +Q963, +Q964, +Q978 or +Q979). For safety reasons, install the emergency stop devices at each operator control station and at other operating stations where emergency stop may be needed.

**Note:** Pressing the stop key  on the control panel of the drive, or turning the operating switch of the drive from position “1” to “0” does not generate an emergency stop of the motor or separate the drive from dangerous potential.

---

See the appropriate user's manual for the wiring, start-up and operation instructions.

Option code	User's manual	Manual code (English)
+Q951	Emergency stop, stop category 0 (using main contactor/breaker)	<a href="#">3AUA0000119895</a>
+Q952	Emergency stop, stop category 1 (using main contactor/breaker)	<a href="#">3AUA0000119896</a>
+Q963	Emergency stop, stop category 0 (using Safe torque off)	<a href="#">3AUA0000119908</a>
+Q964	Emergency stop, stop category 1 (using Safe torque off)	<a href="#">3AUA0000119909</a>
+Q978	Emergency stop, stop category 0 or 1 (using main contactor/breaker and Safe torque off)	<a href="#">3AUA0000145920</a>
+Q979	Emergency stop, stop category 0 or 1 (using Safe torque off)	<a href="#">3AUA0000145921</a>

## Implementing the Safe torque off function

See chapter [The Safe torque off function](#) (page 265).

## Implementing the ATEX-certified Safe motor disconnection function (option +Q971)

With option +Q971, the drive provides ATEX-certified safe motor disconnection without contactor using the drive Safe torque off function. Option +Q971 is available with options +L537, +L513 or +L514.

For more information, see

- *FPTC-02 ATEX-certified thermistor protection module, Ex II (2) GD (option +L537+Q971) for ACS880 drives user's manual* (3AXD50000027782 [English])
- *ATEX-certified motor thermal protection functions for cabinet-built ACS880 drives (options +L513+Q971 and +L514+Q971) user's manual* (3AXD50000014979 [English]).

## Implementing the Prevention of unexpected start-up function

The drive can be equipped with a Prevention of unexpected start-up (POUS) function either with an FSO-xx safety functions module (option +Q950) or with a safety relay (option +Q957). The POUS function enables short-time maintenance work (like cleaning) on the non-electrical parts of the machinery without switching off and disconnecting the drive.

See the appropriate user's manual for the wiring, start-up and operation instructions.

Option code	User's manual	Manual code (English)
+Q950	Prevention of unexpected start-up, with FSO-xx safety functions module	<a href="#">3AUA0000145922</a>
+Q957	Prevention of unexpected start-up, with safety relay	<a href="#">3AUA0000119910</a>

## Implementing the functions provided by the FSO-xx safety functions module (option +Q972 or +Q973)

The drive can be equipped with an FSO-xx safety functions module (option +Q972 or +Q973) which enables the implementation of functions such as Safe brake control (SBC),

Safe stop 1 (SS1), Safe stop emergency (SSE), Safely limited speed (SLS) and Safe maximum speed (SMS).

The settings of the FSO-xx are at default when delivered from the factory. The connectors of the module are pre-wired to terminal block X68. The wiring of the external safety circuit and configuration of the FSO-xx module are the responsibility of the machine builder.

The FSO-xx reserves the standard Safe torque off (STO) connection of the motor-side control unit. STO can still be utilized by other safety circuits through the FSO-xx.

For wiring instructions, safety data and more information on the functions provided by the FSO-xx, refer to its manual.

## ■ Declaration of Conformity

See page [236](#).

## Implementing the Power-loss ride-through function

Implement the power-loss ride-through function as follows:

Check that the power-loss ride-through function of the inverter unit is enabled with parameter *30.31 Undervoltage control* in the ACS880 primary control program.



**WARNING!** Make sure that the flying restart of the motor will not cause any danger. If you are in doubt, do not implement the Power-loss ride-through function.

---

The main contactor of the drive opens in a power-loss situation. When the power returns, the contactor closes. However, if the power-loss situation lasts so long that the drive trips on undervoltage, it must be reset and started again to continue operation. If the power-loss situation lasts so long that the buffer module (see page [47](#)) runs out, the main contactor remains open and the drive operates only after reset and a new start.

With external uninterruptible control voltage (option +G307), the main contactor remains closed in power-loss situations. If the power-loss situation lasts so long that the drive trips on undervoltage, it must be reset and started again to continue operation.

## Supplying power for the auxiliary circuits

The drive is equipped with an auxiliary control voltage transformer which supplies control voltage, for example, for the control devices and cabinet fan(s).

The following options are to be supplied from external power sources:

- +G300/+G301: Cabinet heaters and/or lighting (230 or 115 V AC; external fuse: 16 A)
  - +G307: Connection for an external uninterruptible power supply (230 or 115 V AC; external fuse: 16 A) to the control unit and control devices when the drive is not powered
  - +G313: Power supply connection (230 V AC; external fuse 16 A) for a motor space heater output.
-

## Using power factor compensation capacitors with the drive

Power factor compensation is not needed with AC drives. However, if a drive is to be connected in a system with compensation capacitors installed, note the following restrictions.



**WARNING!** Do not connect power factor compensation capacitors or harmonic filters to the motor cables (between the drive and the motor). They are not meant to be used with AC drives and can cause permanent damage to the drive or themselves.

---

If there are power factor compensation capacitors in parallel with the three phase input of the drive:

1. Do not connect a high-power capacitor to the power line while the drive is connected. The connection will cause voltage transients that may trip or even damage the drive.
2. If capacitor load is increased/decreased step by step when the AC drive is connected to the power line, make sure that the connection steps are low enough not to cause voltage transients that would trip the drive.
3. Check that the power factor compensation unit is suitable for use in systems with AC drives, ie, harmonic generating loads. In such systems, the compensation unit should typically be equipped with a blocking reactor or harmonic filter.

## Implementing a safety switch between the drive and the motor

We recommend to install a safety switch between the permanent magnet synchronous motor and the drive output. The switch is needed to isolate the motor during any maintenance work on the drive.

## Using a contactor between the drive and the motor

Implementing the control of the output contactor depends on how you select the drive to operate. See also section [Implementing a bypass connection](#) on page 102.

When you have selected to use DTC motor control mode, and motor ramp stop, open the contactor as follows:

1. Give a stop command to the drive.
2. Wait until the drive decelerates the motor to zero speed.
3. Open the contactor.

When you have selected to use DTC motor control mode, and motor coast stop, or scalar control mode, open the contactor as follows:

1. Give a stop command to the drive.
2. Open the contactor.



**WARNING!** When the DTC motor control mode is in use, never open the output contactor while the drive controls the motor. The DTC motor control operates extremely fast, much faster than it takes for the contactor to open its contacts. When the contactor starts opening while the drive controls the motor, the DTC control will

---

try to maintain the load current by immediately increasing the drive output voltage to the maximum. This will damage, or even burn the contactor completely.

## Implementing a bypass connection

An application-engineered bypass connection is available from ABB. For more information, see *Bypass connection for ACS880-07, -17, -37 (40...1200 A) option description* (3AXD50000048959 [English]).



**WARNING!** Never connect the drive output to the electrical power network. The connection may damage the drive.

## Protecting the contacts of relay outputs

Inductive loads (relays, contactors, motors) cause voltage transients when switched off.

The relay contacts on the drive control unit are protected with varistors (250 V) against overvoltage peaks. In spite of this, it is highly recommended that inductive loads are equipped with noise attenuating circuits (varistors, RC filters [AC] or diodes [DC]) in order to minimize the EMC emission at switch-off. If not suppressed, the disturbances may connect capacitively or inductively to other conductors in the control cable and form a risk of malfunction in other parts of the system.

Install the protective component as close to the inductive load as possible. Do not install protective components at the relay outputs.

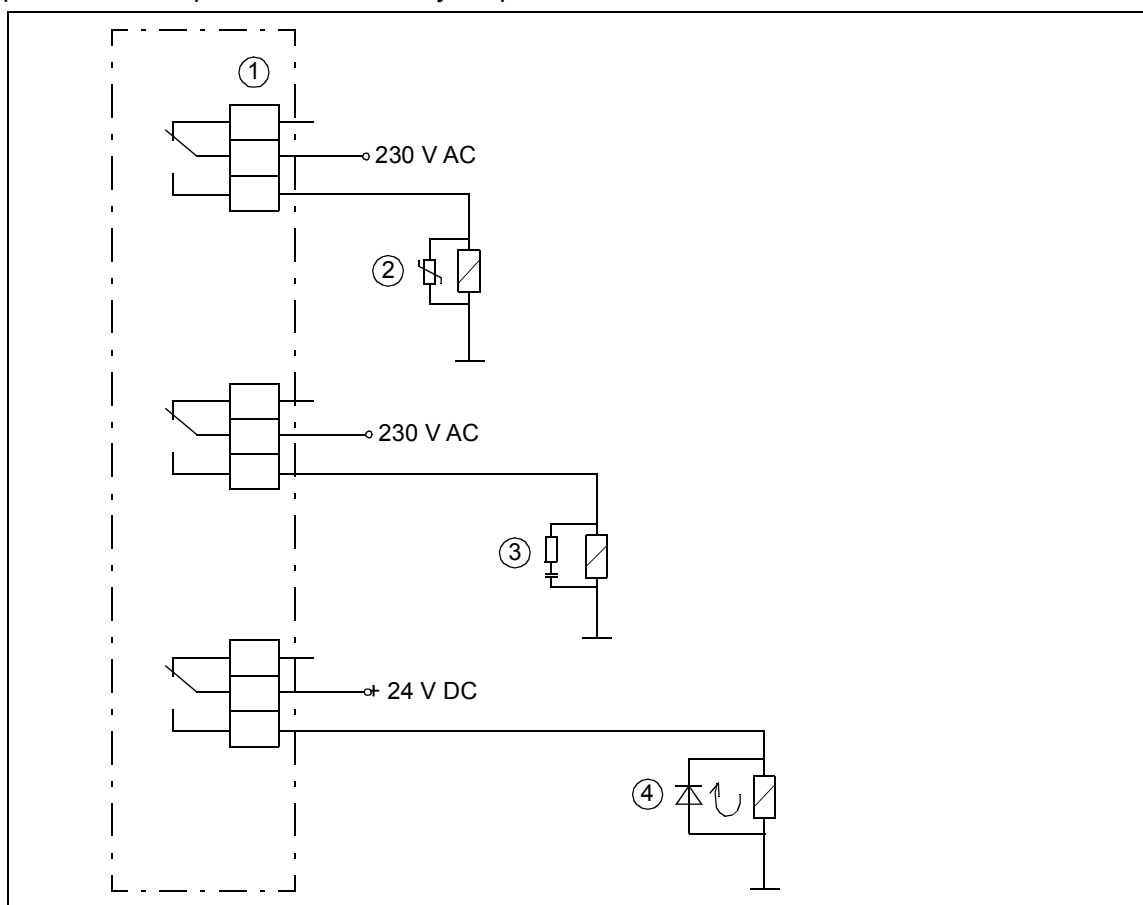

1) Relay outputs; 2) Varistor; 3) RC filter; 4) diode

## Implementing a motor temperature sensor connection



**WARNING!** IEC 60664 and IEC 61800-5-1 require double or reinforced insulation between live parts and the surface of accessible parts of electrical equipment which are either non-conductive or conductive but not connected to the protective earth.

To connect a motor temperature sensor and other similar components to the drive, you have four alternatives:

1. If there is double or reinforced insulation between the sensor and the live parts of the motor, you can connect the sensor directly to the analog/digital inputs of the drive.
2. If there is basic insulation between the sensor and the live parts of the motor, you can connect the sensor to the analog/digital inputs of the drive if all circuits connected to the drive's digital and analog inputs (typically extra-low voltage circuits) are protected against contact and insulated with basic insulation from other low-voltage circuits. The insulation must be rated for the same voltage level as the drive main circuit. Note that extra-low voltage circuits (such as 24 V DC) typically do not meet these requirements.
3. You can connect the sensor to the drive via an option module. The sensor and the module must form a double or reinforced insulation between the motor live parts and the drive control unit. See section [Connection of motor temperature sensor to the drive via an option module](#) (page 103).
4. You can connect the sensor to a digital input of the drive via a relay (internal option or customer's external relay). The sensor and the relay must form a double or reinforced insulation between the motor live parts and the drive control unit. See section [Connection of motor temperature sensor to the drive via a relay](#) (page 104).

### ■ Connection of motor temperature sensor to the drive via an option module

This table shows:

- option module types that you can use for the motor temperature sensor connection
- insulation or isolation level that each option module forms between its temperature sensor connector and other connectors
- temperature sensor types that you can connect to each option module
- temperature sensor insulation requirement in order to form, together with the insulation of the option module, a double or reinforced insulation between the motor live parts and the drive control unit.

Option module		Temperature sensor type			Temperature sensor insulation requirement
Type	Insulation/Isolation	PTC	KTY	Pt100, Pt1000	
FIO-11	Galvanic isolation between sensor connector and other connectors (including drive control unit connector)	-	X	X	Reinforced insulation
FEN-xx	Galvanic isolation between sensor connector and other connectors (including drive control unit connector)	X	X	-	Reinforced insulation

Option module		Temperature sensor type			Temperature sensor insulation requirement
Type	Insulation/Isolation	PTC	KTY	Pt100, Pt1000	
FAIO-01	Basic insulation between sensor connector and drive control unit connector. No insulation between sensor connector and other IO connectors.	X	X	X	Basic insulation. Connectors of option module other than sensor connector must be left unconnected.
FPTC-xx <sup>1)</sup>	Reinforced insulation between sensor connector and other connectors (including drive control unit connector).	X	-	-	No special requirement

<sup>1)</sup> Suitable for use in safety functions (SIL2 / PL c rated)

### ■ Connection of motor temperature sensor to the drive via a relay

**PTC alternative A.** This table shows the insulation of the factory-installed relay (plus code option), insulation requirement for a customer's external relay, and the insulation requirement for the sensor to fulfill decisive voltage class A (double insulation) of IEC 60800-5-1.

PTC relay		Temperature sensor insulation requirement
Type	Insulation	
Drive options +L505 and +L513	Basic insulation 6 kV	Basic insulation
External relay	Basic insulation 6 kV	Basic insulation

**PTC alternative B.** Decisive voltage class B of IEC 60800-5-1 (basic insulation) is provided with a 6 kV relay. Circuits connected to all motor protection relay inputs and outputs must be protected against direct contact.

**Pt100 alternative A.** This table shows the insulation of the factory-installed relay (plus code option), insulation requirement for a customer's external relay, and the insulation requirement for the sensor to fulfill decisive voltage class A (double insulation) of IEC 60800-5-1.

Pt100 relay		Temperature sensor insulation requirement between sensor and live parts of motor
Type	Insulation	
Drive options +L506 and +L514	Basic insulation < 6 kV	Double or reinforced insulation
External relay	Basic insulation 6 kV	Basic insulation

**Pt100 alternative B.** Decisive voltage class B of IEC 60800-5-1 (basic insulation) can be achieved when there is basic insulation between the sensor and live parts of the motor. Circuits connected to all motor protection relay inputs and outputs must be protected against direct contact.



# 6

## Electrical installation

---

### Contents of this chapter

This chapter gives instructions on the wiring the drive.

### Warnings



**WARNING!** Only qualified electrical professionals are allowed to carry out the work described in this chapter. Follow the [Safety instructions](#) on the first pages of this manual. Ignoring the safety instructions can cause injury or death.

---



### Checking the insulation of the assembly

#### ■ Drive

Do not make any voltage tolerance or insulation resistance tests on any part of the drive as testing can damage the drive. Every drive has been tested for insulation between the main circuit and the chassis at the factory. Also, there are voltage-limiting circuits inside the drive which cut down the testing voltage automatically.

#### ■ Input cable

Check the insulation of the input cable according to local regulations before connecting it to the drive.

---

## Motor and motor cable



**WARNING!** Obey the instructions in chapter [Safety instructions](#). If you ignore them, injury or death, or damage to the equipment can occur.



**WARNING!** Use a vacuum cleaner with antistatic hose and nozzle. Using a normal vacuum cleaner creates static discharges which can damage circuit boards.

1. Stop the drive and do the steps in section [Electrical safety precautions](#) (page 19) before you start the work.
2. Check that the motor cable is disconnected from the drive output terminals U2, V2 and W2.
3. Measure the insulation resistance between each phase conductor and the Protective Earth conductor using a measuring voltage of 1000 V DC. The insulation resistance of an ABB motor must exceed 100 Mohm (reference value at 25 °C or 77 °F). For the insulation resistance of other motors, consult the manufacturer's instructions. **Note:** Moisture inside the motor casing will reduce the insulation resistance. If moisture is suspected, dry the motor and repeat the measurement.

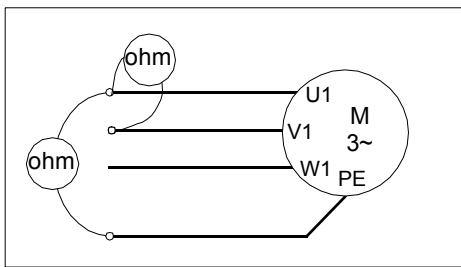

## Checking the compatibility with IT (ungrounded), corner-grounded delta, midpoint-grounded delta and TT systems

The standard drive with ground-to-phase varistors connected can be installed to a symmetrically grounded TN-S system. If you install the drive to another systems, you may need to disconnect the EMC filter and ground-to-phase varistors. For instructions, see [ACS880 frames R1 to R11 EMC filter and ground-to-phase varistor disconnecting instructions](#) (3AUA0000125152 [English]).

### EMC filter (options +E200 or +E202)

A drive with EMC filter options +E200 and +E202 connected can be installed to a symmetrically grounded TN-S system.



**WARNING!** Do not install the drive with the EMC filter options +E200 and +E202 connected to a system that the filter is not suitable for. This can cause danger, or damage the drive.

**Note:** When EMC filter +E200 and +E202 is disconnected, the drive EMC compatibility is considerably reduced.

## ■ Ground-to-phase varistor

A drive with the ground-to-phase varistor connected can be installed to a symmetrically grounded TN-S system.



**WARNING!** Do not install the drive with the ground-to-phase varistor connected to a system that the varistor is not suitable for. If you do, the varistor circuit can be damaged.

## ■ Corner-grounded and midpoint-grounded 690 V delta systems



**WARNING!** Do not install the drive on a 690 V corner-grounded or midpoint-grounded delta system. Disconnecting the EMC filter and ground-to-phase varistor does not prevent damage to the drive.

## Attaching the device stickers to the cabinet door

A multilingual device label sticker is delivered with the drive. Attach the stickers in the local language on the English texts; see section [Door switches and lights](#) (page 52).

## Checking the settings of auxiliary voltage transformers

Check the tap settings of all auxiliary voltage transformers. Set the voltage according to the power network voltage. This figure shows an example connection.

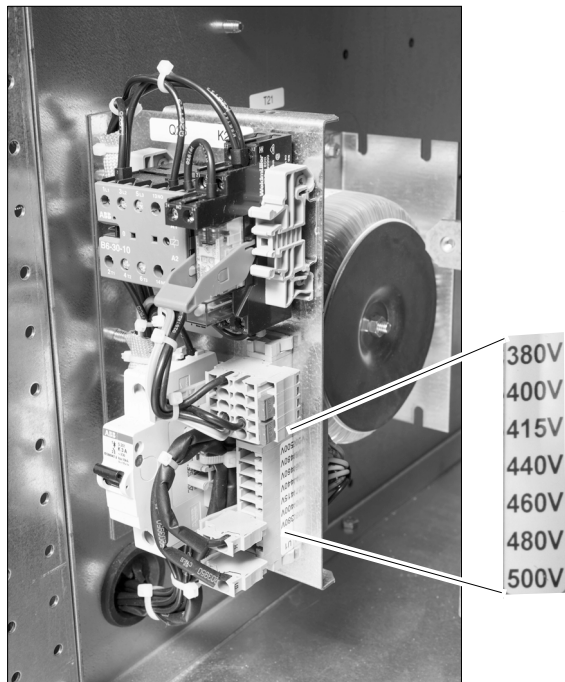

Transformer T21 is included as standard.

In frame R8, additional transformer T101 comes with options +B055 and +C128.

In frame R11, additional transformer T102 comes with options +B055 and +C128, T121.11 with option +D150.

The locations of the transformers are shown on page 40 and page 44.



## Connecting the control cables

See chapter [Control unit of frame R8](#) (page 141) or [Control unit of frame R11](#) (page 151) for the default I/O connections of the inverter unit (with the ACS880 primary control program). The default I/O connections can be different with some hardware options, see the circuit diagrams delivered with the drive for the actual wiring. For other control programs, see their firmware manuals.

### ■ Control cable connection procedure



**WARNING!** Obey the instructions in chapter [Safety instructions](#). If you ignore them, injury or death, or damage to the equipment can occur.

---

1. Stop the drive (if running) and do the steps in section [Electrical safety precautions](#) (page 19) before you start the work.
2. Run the control cables into the drive module cubicle as described in section [Grounding the outer shields of the control cables at the cabinet entry](#) (page 109).
3. Route the control cables as described in section [Routing the control cables inside the cabinet](#) (page 111).
4. Connect the control cables as described starting on page 116.



## Grounding the outer shields of the control cables at the cabinet entry

### Applicability

This section applies to drives without solid cable conduit plate (no options +C129, +C134, +H358).

### Procedure

Ground the outer shields of all control cables 360 degrees at the EMI conductive cushions as follows:

1. Loosen the tightening screws of the EMI conductive cushions and pull the cushions apart.
2. Cut adequate holes to the rubber grommets in the entry plate and lead the cables through the grommets and the cushions into the cabinet.
3. Strip off the cable plastic sheath above the entry plate just enough to ensure proper connection of the bare shield and the EMI conductive cushions.
4. Tighten the two tightening screws so that the EMI conductive cushions press tightly round the bare shield.

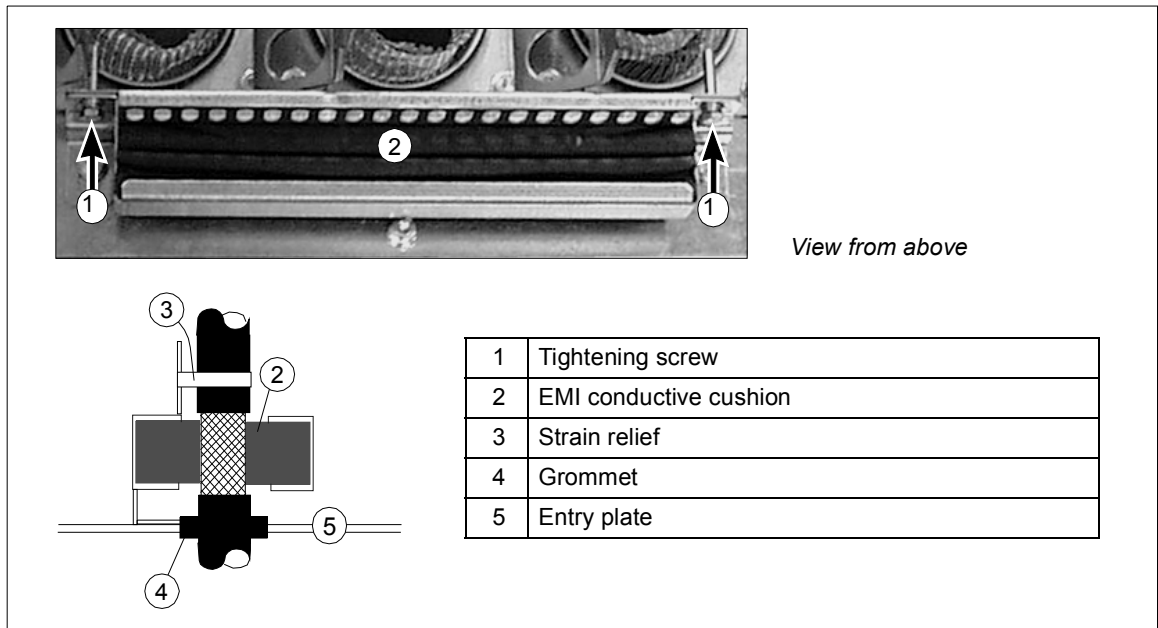

**Note 1:** Keep the shields continuous as close to the connection terminals as possible. Secure the cables mechanically at the entry strain relief.

**Note 2:** If the outer surface of the shield is non-conductive:

- Cut the shield at the midpoint of the bare part. Be careful not to cut the conductors or the grounding wire (if present).
- Turn the shield inside out to expose its conductive surface.

- Cover the turned shield and the stripped cable with copper foil to keep the shielding continuous.

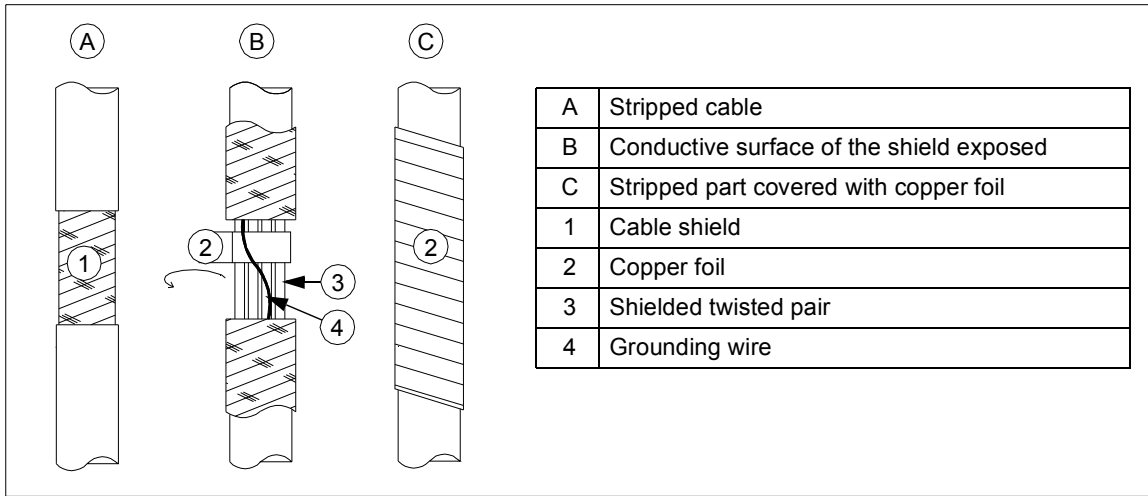

**Note for top entry of cables:** When each cable has its own rubber grommet, sufficient IP and EMC protection can be achieved. However, if very many control cables come to one cabinet, plan the installation beforehand as follows:

1. Make a list of the cables coming to the cabinet.
2. Sort the cables going to the left into one group and the cables going to the right into another group to avoid unnecessary crossing of cables inside the cabinet.
3. Sort the cables in each group according to size.
4. Group the cables for each grommet as follows ensuring that each cable has a proper contact to the cushions on both sides.

Cable diameter in mm	Max. number of cables per grommet
≤ 13	4
≤ 17	3
< 25	2
≥ 25	1

5. Arrange the bunches according to size from thickest to the thinnest between the EMI conductive cushions.

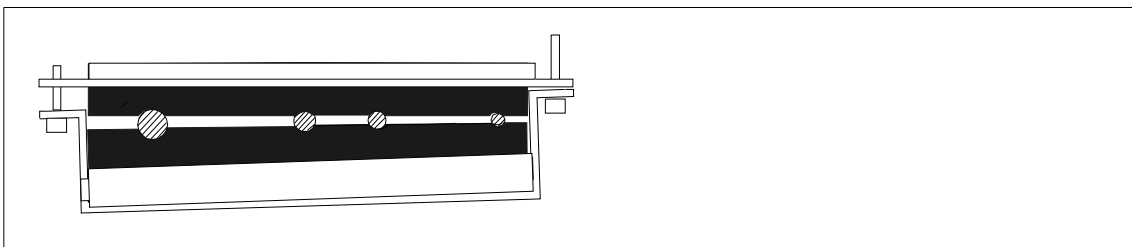

If more than one cable go through a grommet, seal the grommet by applying Loctite 5221 (catalogue number 25551) inside the grommet.

## Routing the control cables inside the cabinet

Use the existing trunking in the cabinet wherever possible. Use sleeving if cables are laid against sharp edges. When running cables to or from the swing-out frame, leave enough slack at the hinge to allow the frame to open fully.

### Frame R8

1. Stop the drive and do the steps in section [Electrical safety precautions](#) (page 19) before you start the work.
2. Open the cabinet door.
3. If there is a mounting plate above the fan, loosen the four screws and pull out the plate. Unplug the connectors and remove the plate.  
If there is no mounting plate, but instead a shroud above the fan, undo the four screws and remove the shroud.
4. Remove the “door fan” (see section [Replacing the cabinet “door fan”](#) on page 174).
5. See page 50. Bottom entry: Route the cables of these options to the connection terminals at the right-hand side of the cabinet as shown below. Top entry, see page 113.

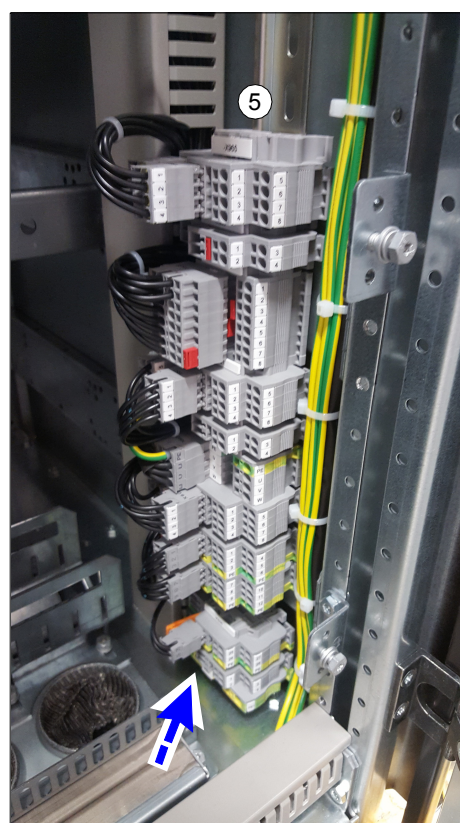
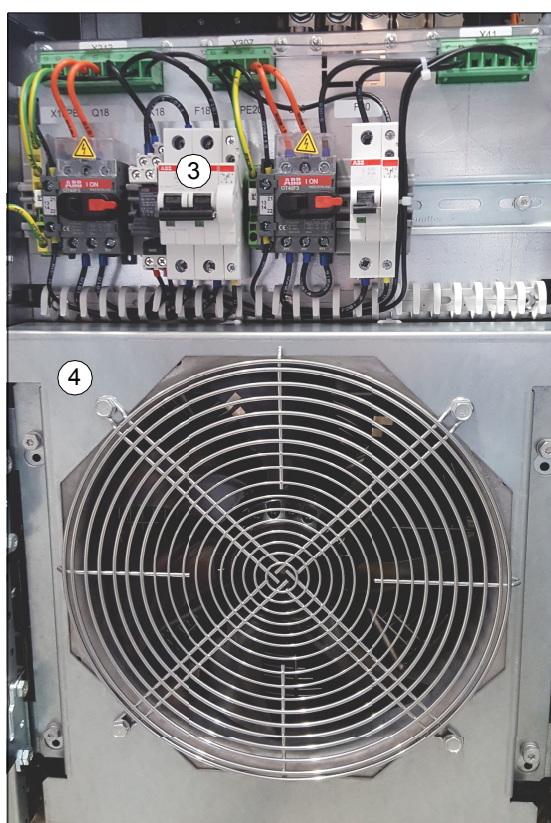

Line contactor and main switch feedback for customer
--

Prevention of unexpected start-up with safety relays (option +Q957)
---

Push buttons for emergency stop options +Q951, +Q952, +Q963 and +Q964
---

Ground fault monitoring for IT (ungrounded) systems (option +Q954)
--

External STO customer connection for safety options +Q951, +Q952, +Q963, +Q964, +Q957 and +Q971
---

Starter for auxiliary motor fan (options +M600...+M605)
---

Thermistor relay or Pt100 relays (option +L505 or +L506)
--

6. Drives with swing-out frame: Open the swing-out frame (a).  
Marine drives (option +C121): To open the swing-out frame, undo the three M6 screws on the left side of the swing-out frame.  
Drives without swing-out frame: Remove the shroud (b).

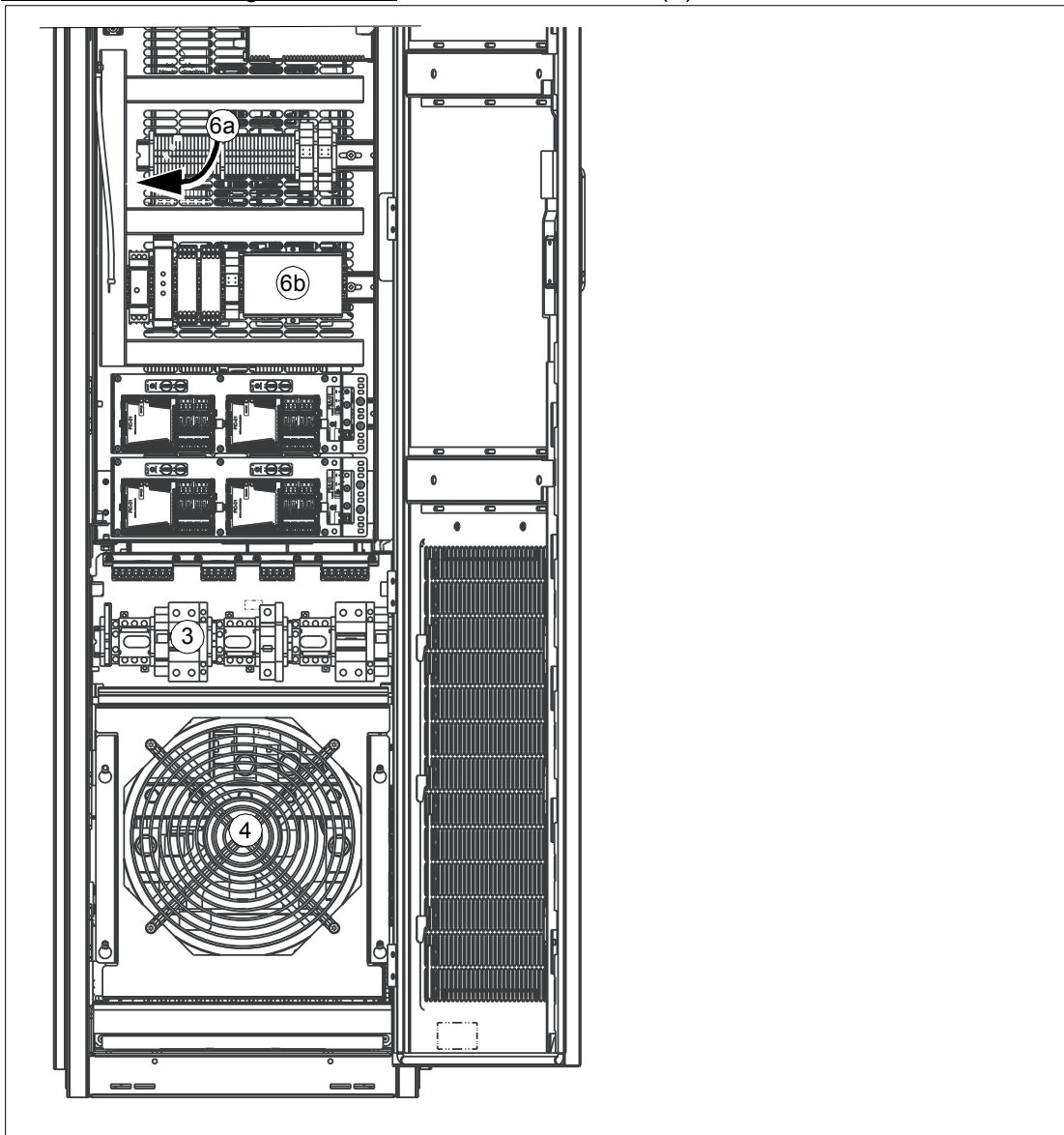



7. Route the cables to the control unit (a) and additional terminal block X504 (option +L504) and to options +QXXX, +MXXX, +L505 and +L506 as shown below.

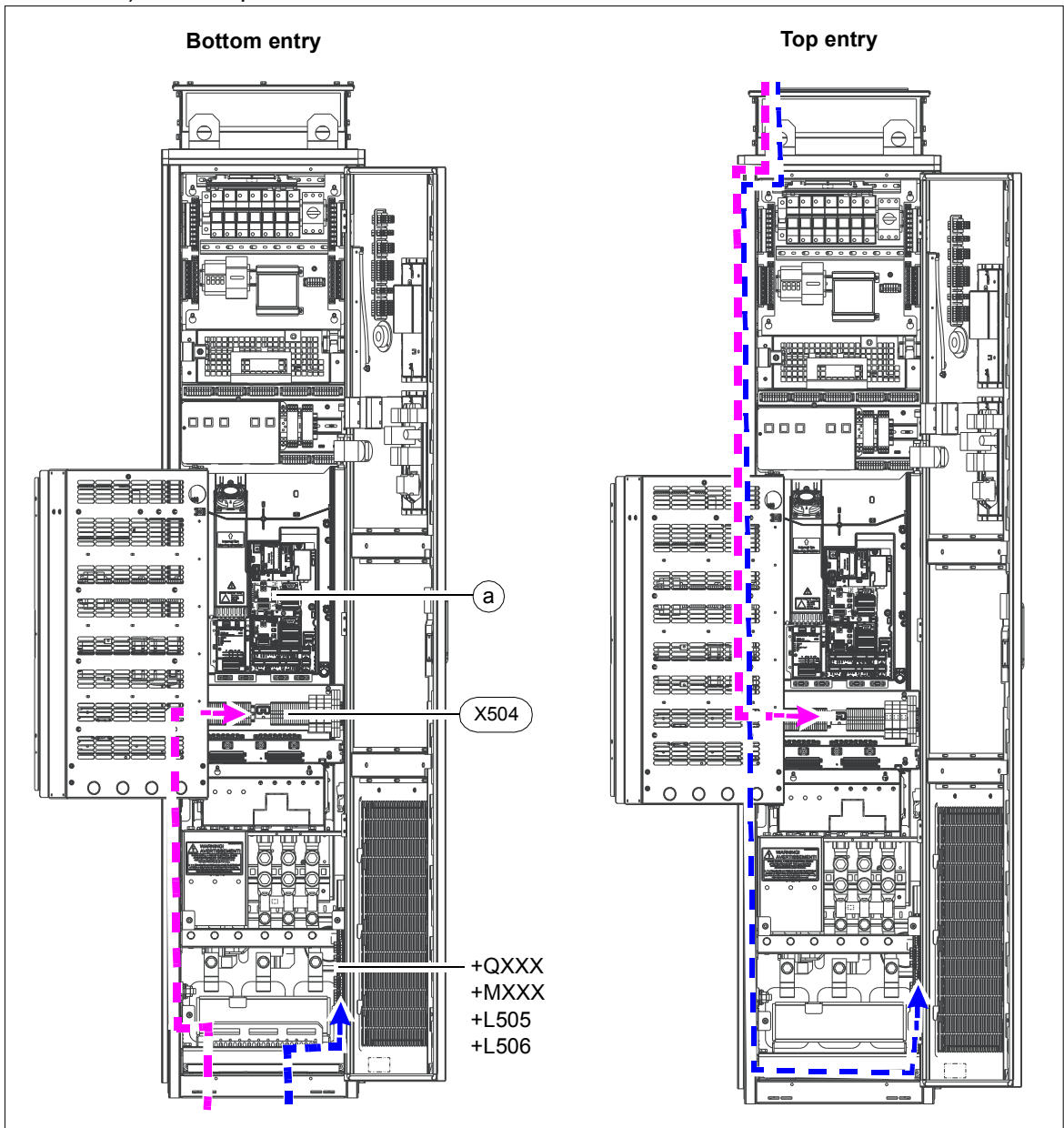

Frame R11

1. Stop the drive and do the steps in section [Electrical safety precautions](#) (page 19) before you start the work.
1. Open the cabinet door.
2. If there is a mounting plate/two plates above the fan, loosen the four screws of the plate and pull out the plate/s. Unplug the connectors and remove the plate/s.  
If there is no mounting plate/s, but instead a shroud/s above the fan, undo the four screws and remove the shroud/s.
3. Remove the “door fan” (see section [Replacing the cabinet “door fan”](#) on page 174).
4. See page 51. Bottom entry: Route the cables of these options to the connection terminals at the left-hand side of the cabinet as shown below.

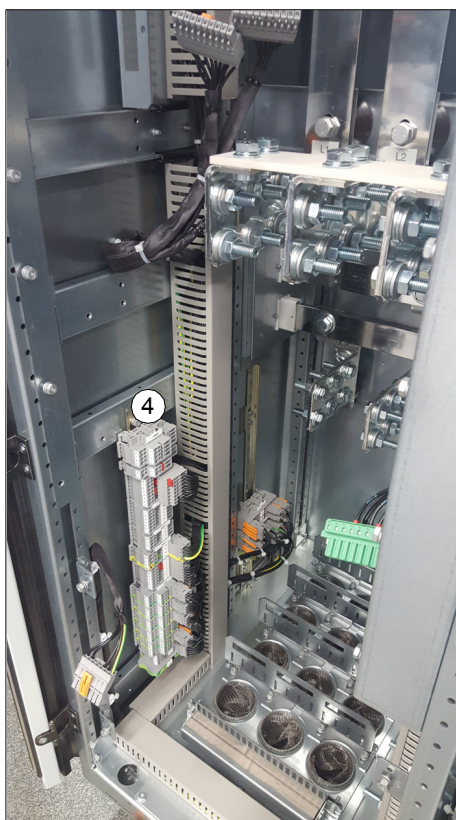
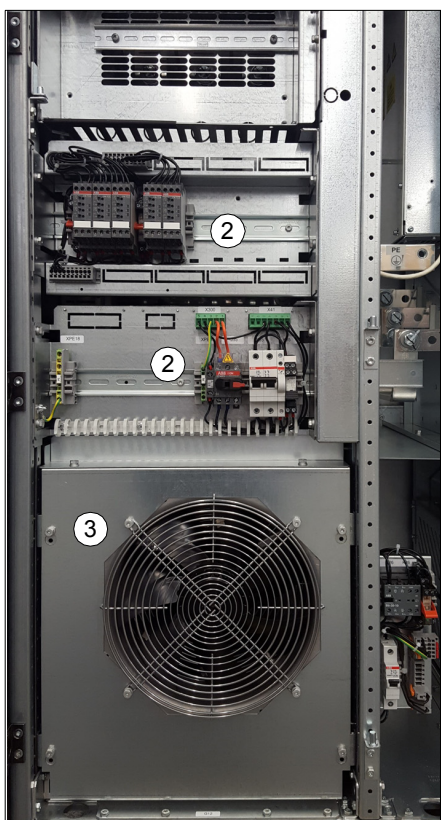

Line contactor and main switch feedback for customer
Prevention of unexpected start-up with safety relays (option +Q957)
Push buttons for emergency stop options +Q951, +Q952, +Q963 and +Q964
Ground fault monitoring for IT (ungrounded) systems (option +Q954)
External STO customer connection for safety options +Q951, +Q952, +Q963, +Q964, +Q957 and +Q971
Starter for auxiliary motor fan (options +M600...+M605)
Thermistor relay or Pt100 relays (option +L505 or +L506)

5. Bottom entry: Route the cables to the control unit, additional terminal block X504 (option +L504) as shown below.

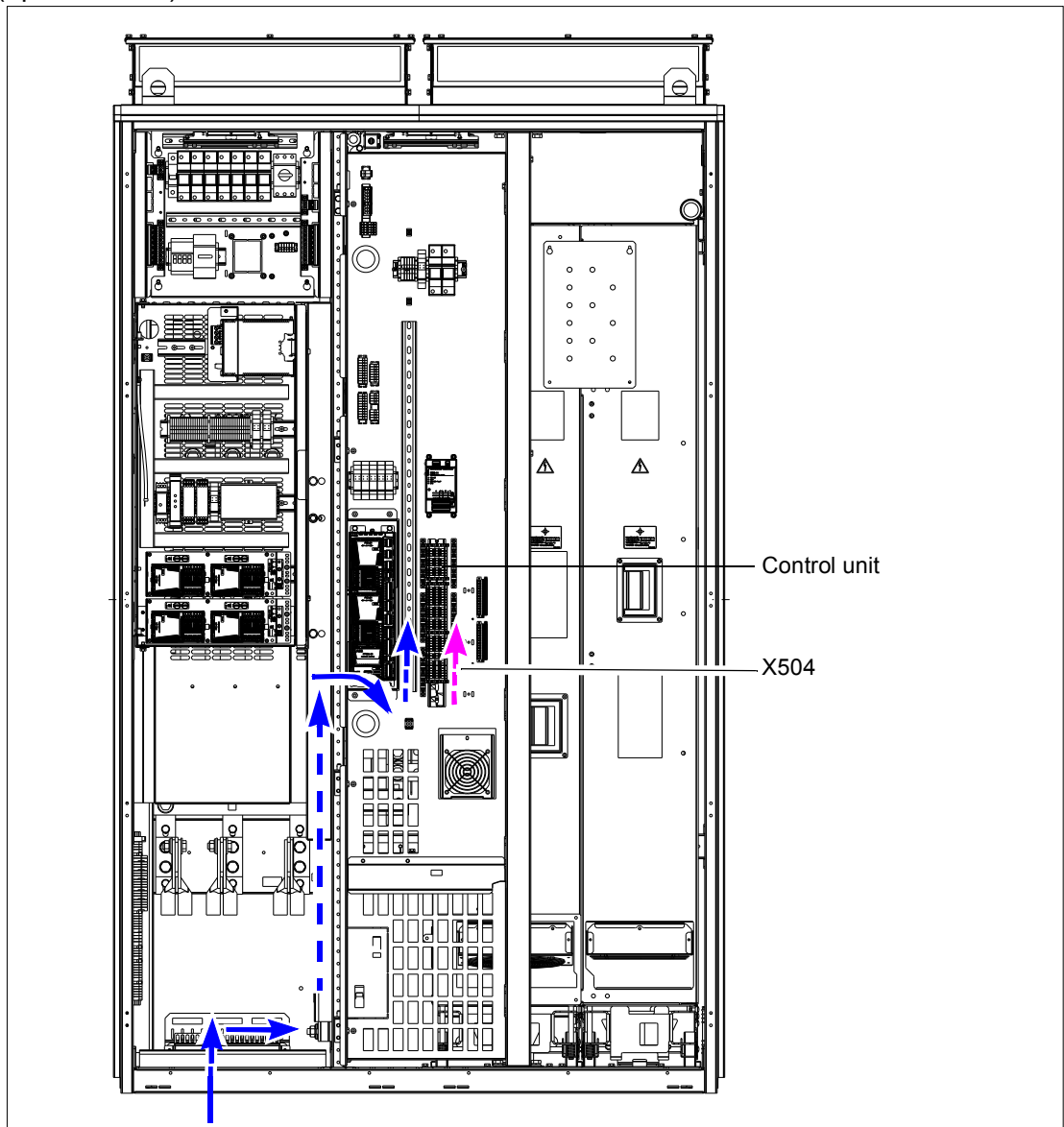

Top entry: Route the control cables to the control unit and additional terminal block X504 (option +L504) as shown below (standard cabinet and option +B054 with blue color; option +B055 with green).

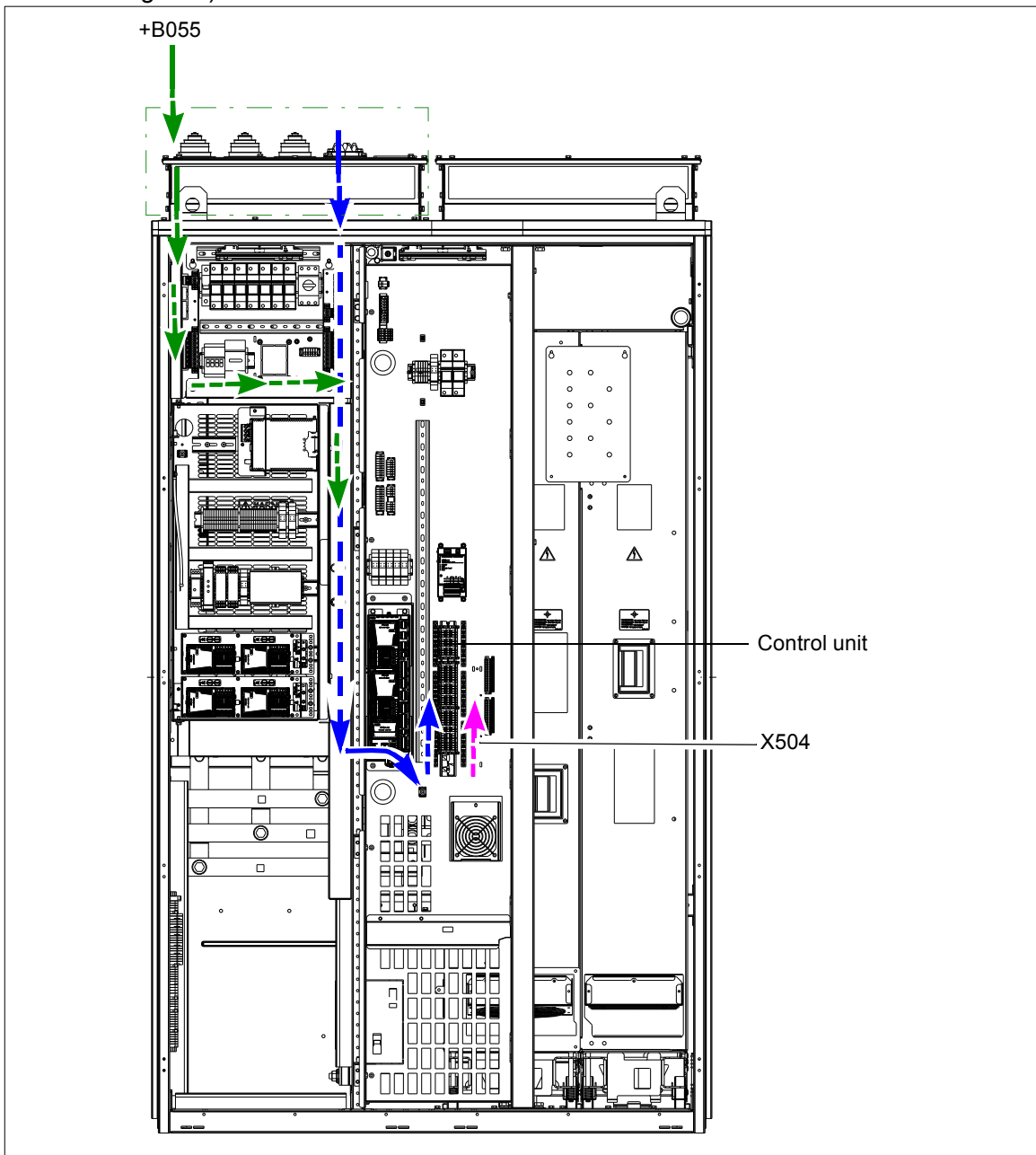

### Connecting to the drive control unit

To connect the conductors to the terminals of the drive control unit or terminal block X504 (option +L504), see section [Default I/O connection diagram of frame R8](#) on page 143 or [Default I/O connection diagram of frame R11](#) on page 153.

Connect the inner twisted pair shields and all separate grounding wires to the grounding clamps next the control unit or the optical terminal block.

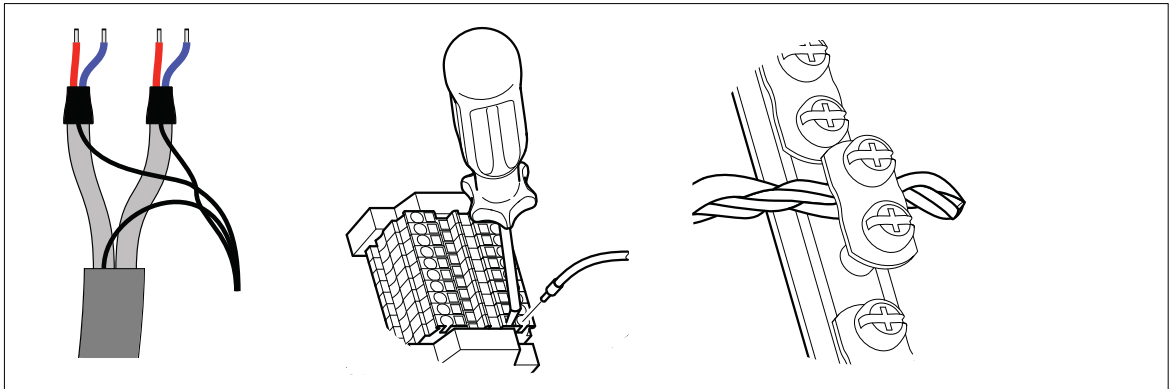

**Notes:**

- Do not ground the outer shield of the cable here since it is grounded at the entry.
- Keep any signal wire pairs twisted as close to the terminals as possible. Twisting the wire with its return wire reduces disturbances caused by inductive coupling.

At the other end of the cable, leave the shields unconnected or ground them indirectly via a high-frequency capacitor with a few nanofarads, eg. 3.3 nF / 630 V. The shield can also be grounded directly at both ends if they are in the same ground line with no significant voltage drop between the end points.

**Connecting an auxiliary voltage supply (UPS, option +G307)**

Wire the external control voltage to terminal block X307 at the back side of the mounting plate as shown below.

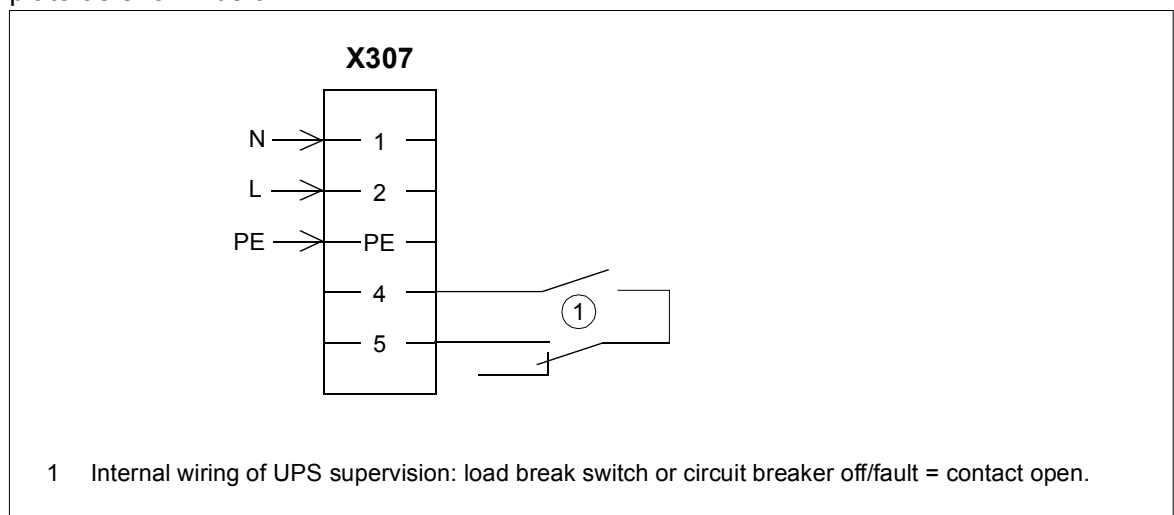

**Connecting emergency stop push buttons (options +Q951, +Q952, +Q963, +Q964, +Q978, +Q979)**

Connect external emergency stop push buttons according to the circuit diagrams delivered with the drive.

**Wiring the starter for auxiliary motor fan (options +M600...+M605)**

Connect the power supply wires for the auxiliary motor fan to terminal block X601 according to the circuit diagrams delivered with the drive.

### Wiring the PTC thermistor relay(s) (options +L505, +2L505, +L513, +2L513)

The external wiring of option +2L505 and +2L513 (two thermistor relays) is shown below. For example, one relay can be used to monitor the motor windings, the other to monitor the bearings. The maximum contact load capacity is 250 V AC 10 A. For the actual wiring, see the circuit diagram delivered with the drive. For instructions on commissioning options +L513 and +2L513, see *ATEX-certified motor thermal protection functions for cabinet-built ACS880 drives (options +L513+Q971 and +L514+Q971) user's manual* (3AXD50000014979 [English]).

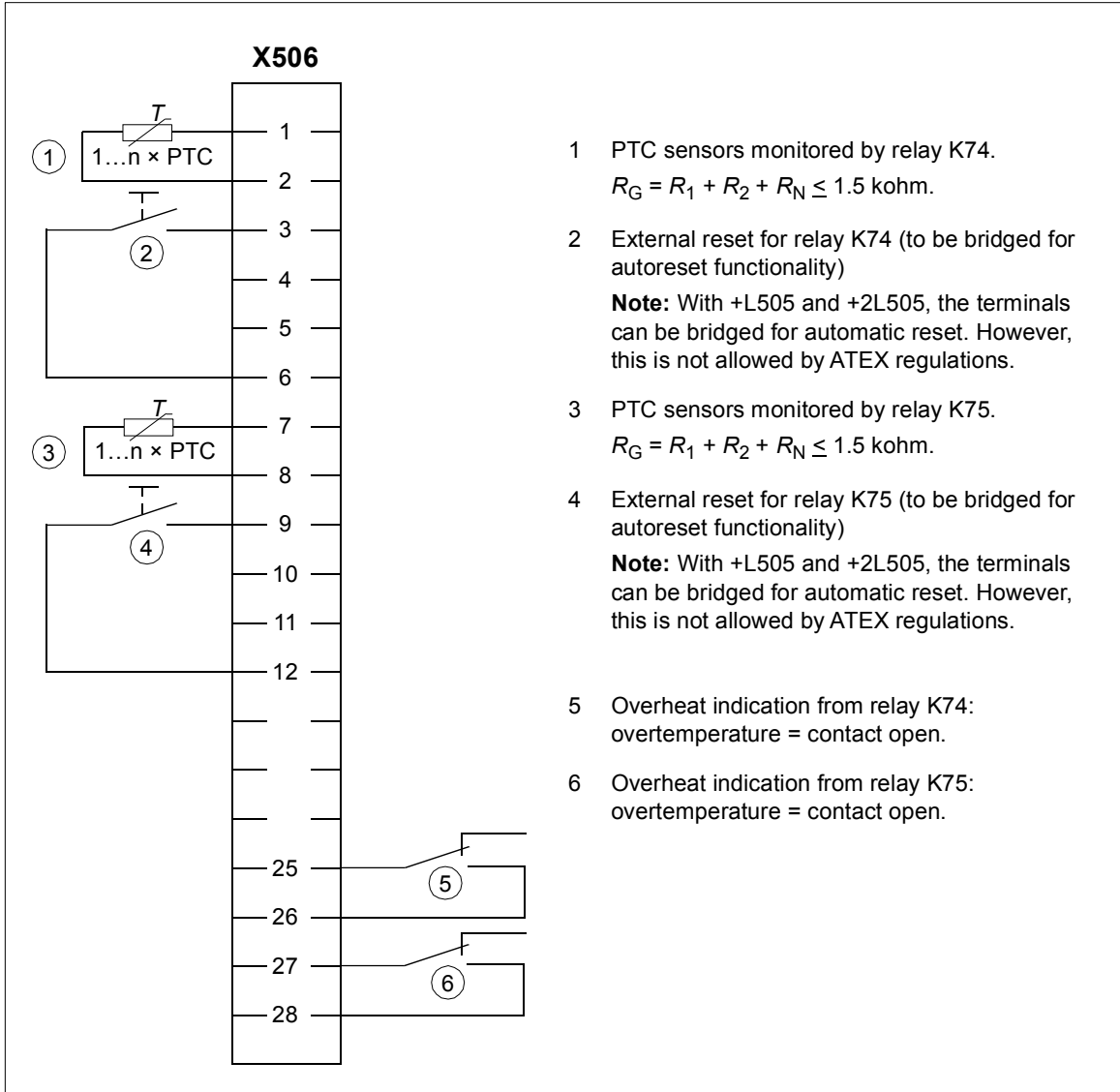

### Wiring the Pt100 relays (option +nL506)

External wiring of eight Pt100 sensor modules is shown below. Contact load capacity 250 V AC 10 A. For the actual wiring, see the circuit diagram delivered with the drive.

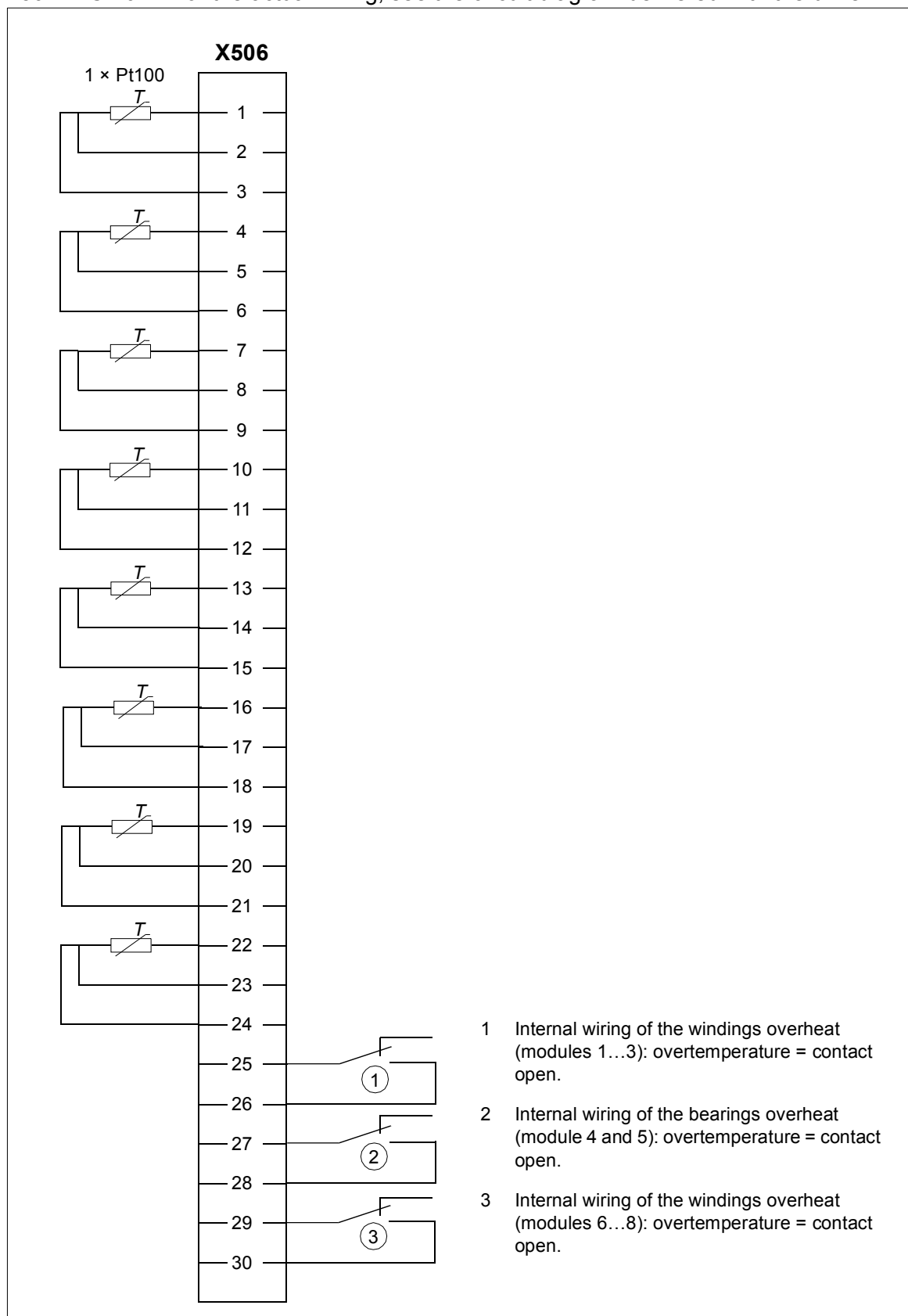

### Wiring the Pt100 relays (option +nL514)

External wiring of three Pt100 sensors is shown below. The maximum contact load capacity is 250 V AC 10 A. For the actual wiring, see the circuit diagram delivered with the drive. For instructions on commissioning option +nL514, see *ATEX-certified motor thermal protection functions for cabinet-built ACS880 drives (options +L513+Q971 and +L514+Q971) user's manual (3AXD50000014979 [English])*.

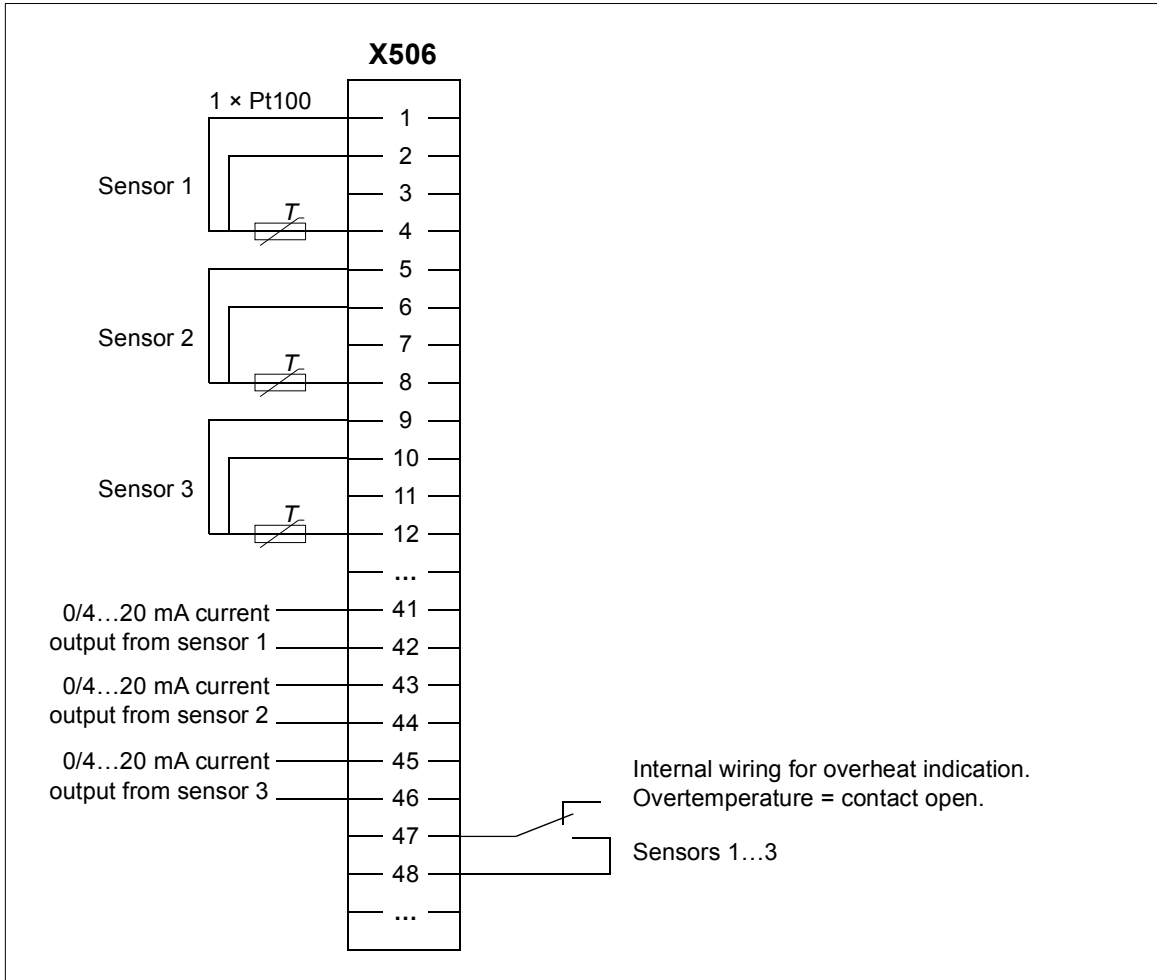



### Powering the heating and lighting equipment (options +G300, +G301 and +G313)

See the circuit diagrams delivered with drive.

Connect the external power supply wires for the cabinet heater and lighting to terminal block X300 at the back of the mounting plate. For the actual wiring, see the circuit diagram delivered with the drive.

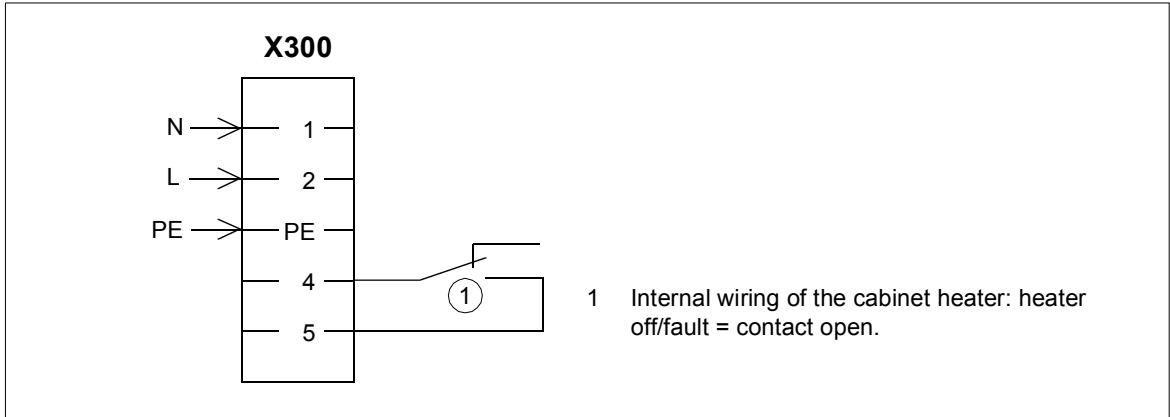

Connect the motor heater wiring to terminal block X313 as shown below. Maximum external power supply 16 A. For the actual wiring, see the circuit diagram delivered with the drive.

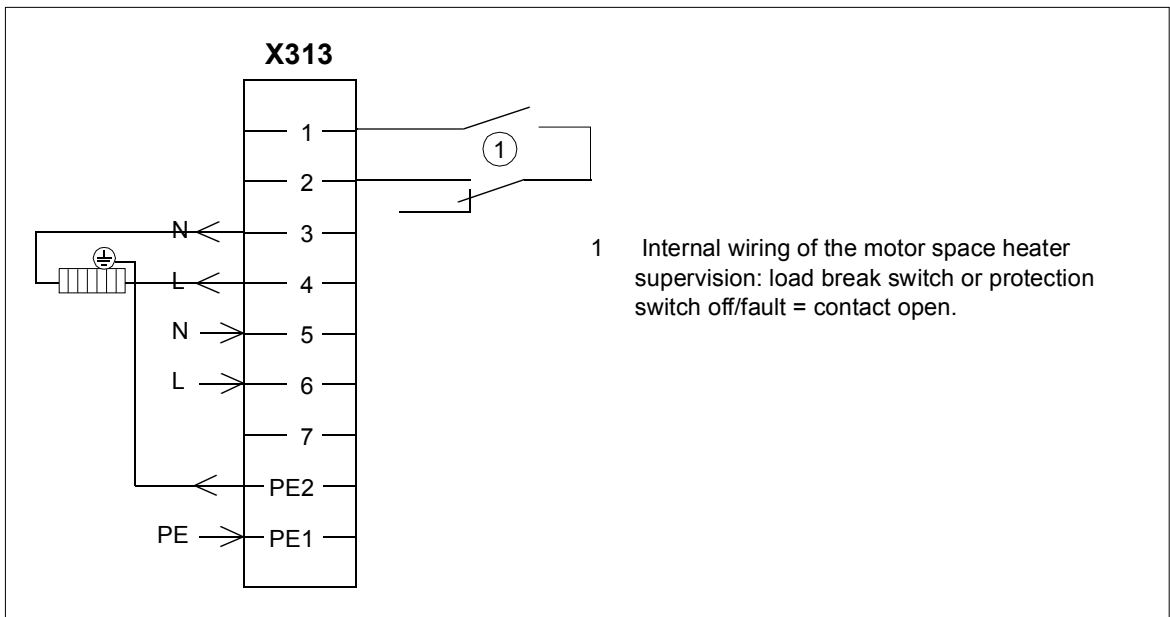

### Wiring ground fault monitoring for IT ungrounded systems (option +Q954)

We recommend to connect Alarm 1 for drive tripping and Alarm 2 for alarm signals in order to avoid unnecessary trippings due to the ground fault monitor self testing with Alarm 2. For the actual wiring, see the circuit diagram delivered with the drive.

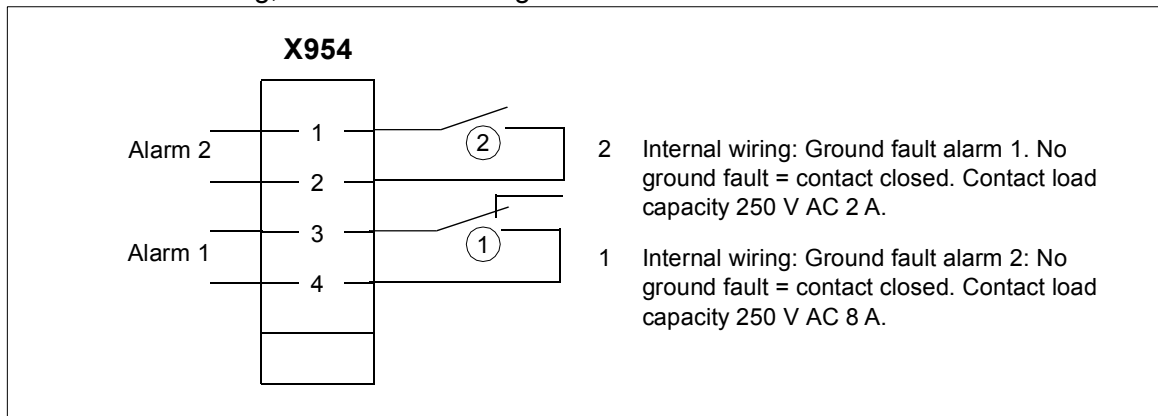

## Connecting the power cables

### ■ Connection diagram

#### Connection diagram of frame R8

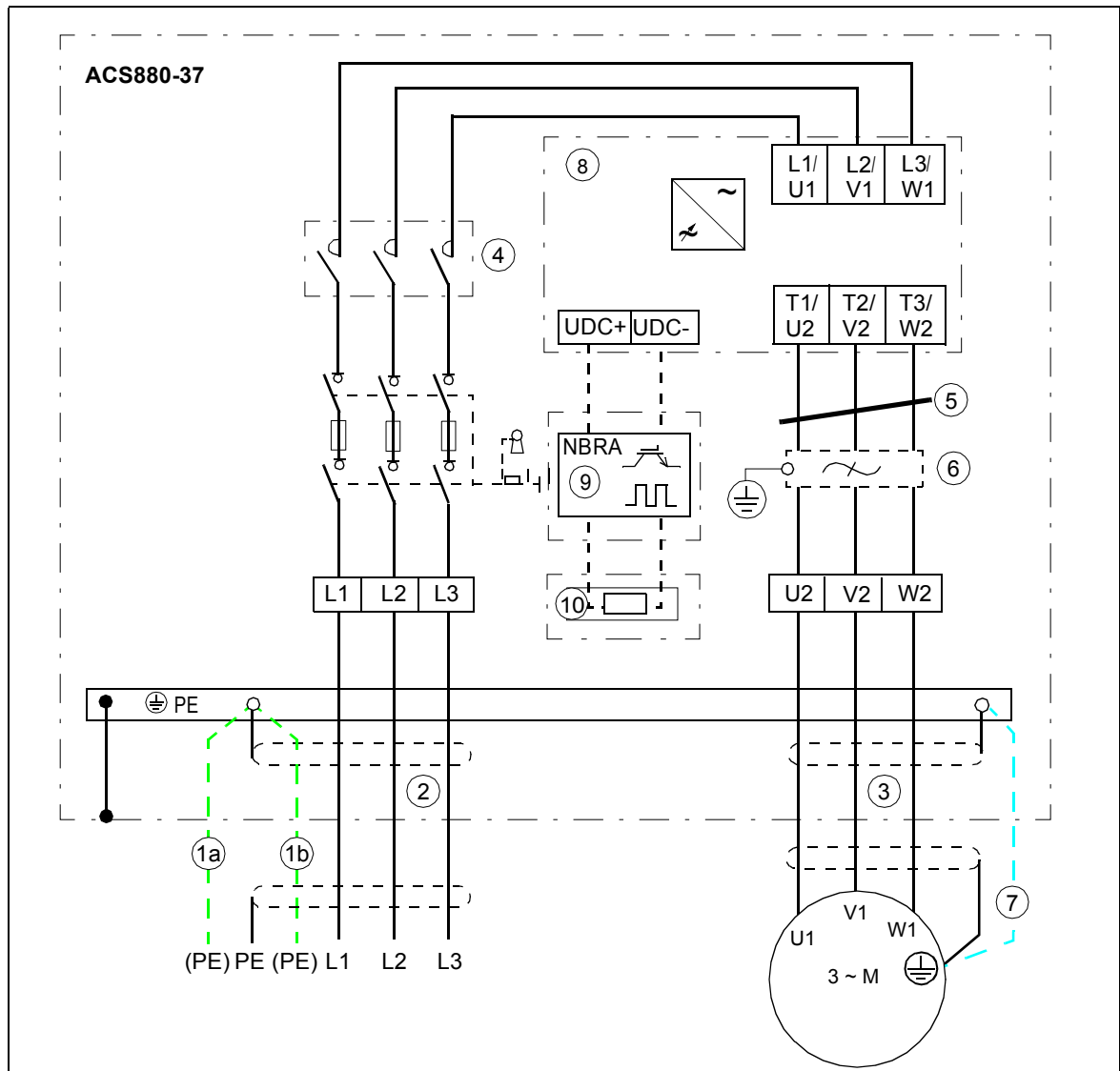

- 1 Use a separate grounding PE cable (1a) or a cable with a separate PE conductor (1b) if the conductivity of the shield does not meet the requirements for the PE conductor (see page 90).
- 2 360-degree grounding is recommended if shielded cable is used. Ground the other end of the input cable shield or PE conductor at the distribution board.
- 3 360-degree grounding is required.
- 4 Line contactor (option for +Q951, +Q952, +Q978)
- 5 Common mode filter (option +E208)
- 6 du/dt filter or sine filter (options +E205 and +E206)
- 7 Use a separate grounding cable if the shield does not meet the requirements of IEC 61439-1 (see page 90) and there is no symmetrically constructed grounding conductor in the cable (see page 92).
- 8 Drive module
- 9 Brake chopper (option +D150)
- 10 Brake resistor (option +D151)

**Note:**

If there is a symmetrically constructed grounding conductor on the motor cable in addition to the conductive shield, connect the grounding conductor to the grounding terminal at the drive and motor ends.

Do not use an asymmetrically constructed motor cable. Connecting its fourth conductor at the motor end increases bearing currents and causes extra wear.

**Connection diagram of frame R11**

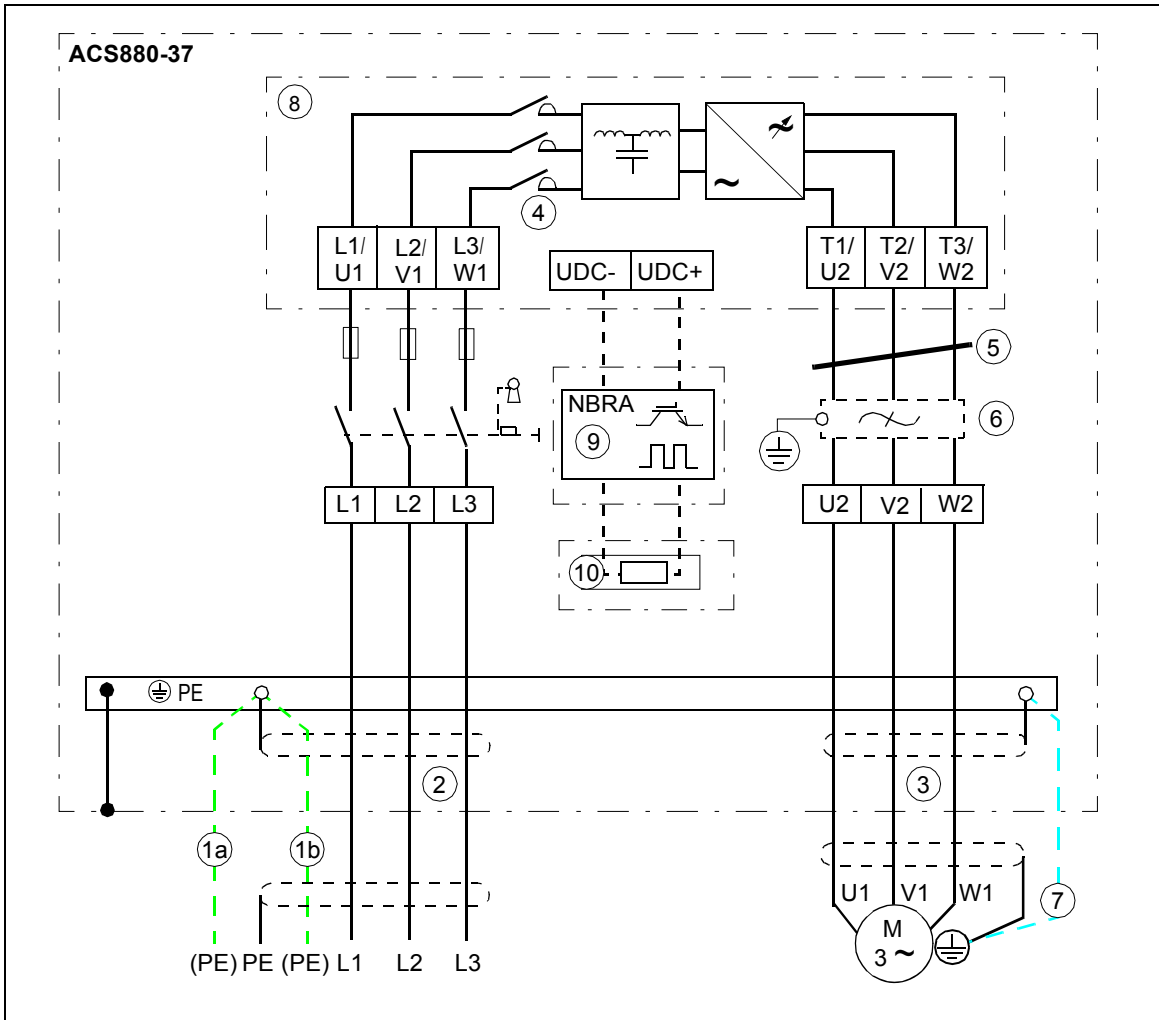

- 1 Use a separate grounding PE cable (1a) or a cable with a separate PE conductor (1b) if the conductivity of the shield does not meet the requirements for the PE conductor (see page 90).
- 2 360-degree grounding is recommended if shielded cable is used. Ground the other end of the input cable shield or PE conductor at the distribution board.
- 3 360-degree grounding is required.
- 4 Line contactor
- 5 Common mode filter (option +E208)
- 6 du/dt filter (option +E205) or sine filter (option +E206)
- 7 Use a separate grounding cable if the shield does not meet the requirements of IEC 61439-1 (see page 90) and there is no symmetrically constructed grounding conductor in the cable (see page 92).
- 8 Drive module
- 9 Brake chopper (option +D150)
- 10 Brake resistor (option +D151)

**Note:**

If there is a symmetrically constructed grounding conductor on the motor cable in addition to the conductive shield, connect the grounding conductor to the grounding terminal at the drive and motor ends.

Do not use an asymmetrically constructed motor cable. Connecting its fourth conductor at the motor end increases bearing currents and causes extra wear.



---

---

## ■ Layout of power cable connection terminals and cable entries

The layout of power cable connection terminals and cable entries of the standard drive are shown below.

**Note:** You have to remove the “door fan” to gain access to the cable terminals and entries (see page [174](#)).

### Frame R8

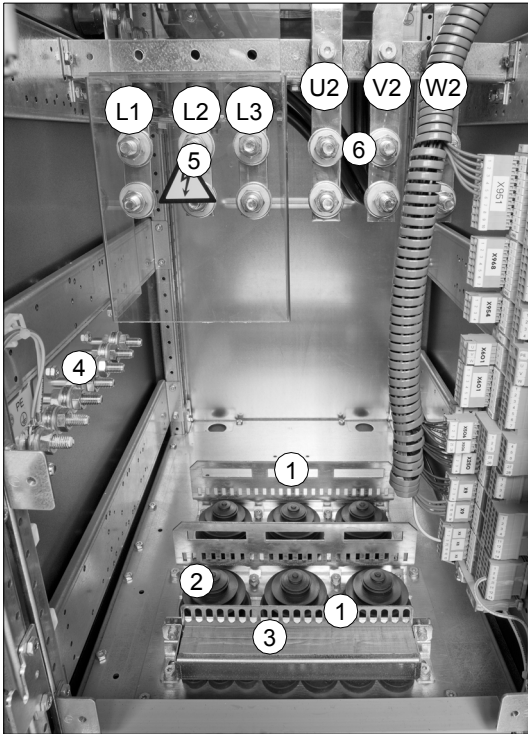

1	Strain relief
2	Power cable entries. Conductive sleeve under the grommet.
3	Control cable entry with EMI conductive cushions.
4	PE terminal
5	Input power cable terminals L1, L2 and L3
6	Motor cable terminals U2, V2, W2

Frame R11

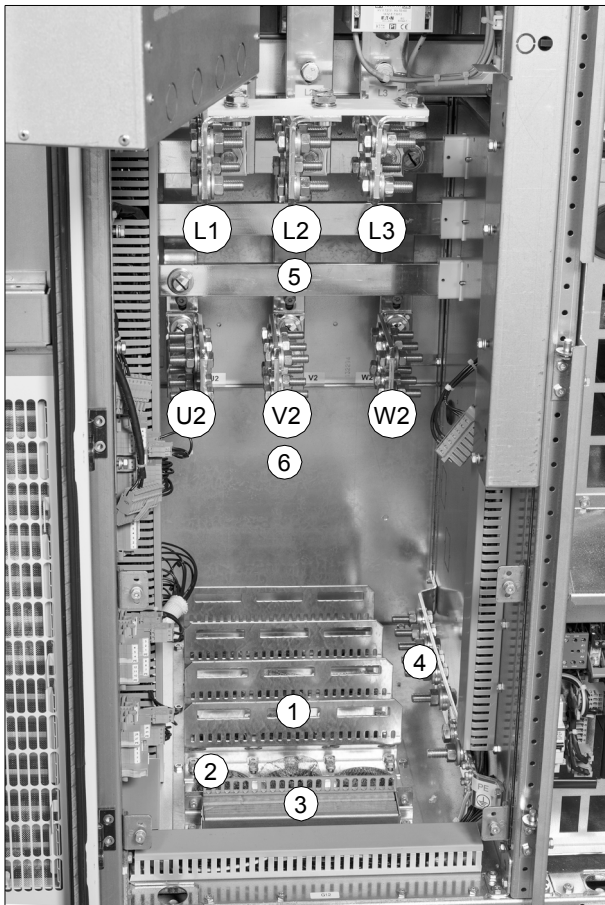

1	Strain relief
2	Power cable entries. Conductive sleeve under the grommet.
3	Control cable entry with EMI conductive cushions.
4	PE terminal
5	Input power cable terminals L1, L2 and L3
6	Motor cable terminals U2, V2, W2



### Layout of power cable connection terminals (option +C129)

This figure shows the layout of the power cable connection terminals of frame R8.

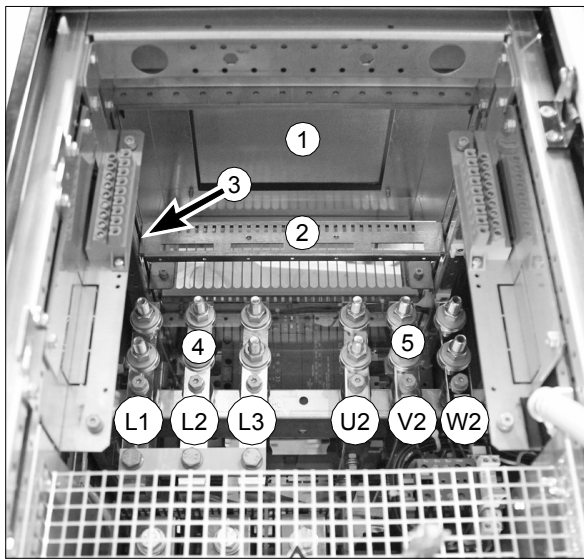

1	Power cable entries
2	Strain relief
3	Ground bar
4	Input cable power connection terminals L1, L2 and L3
5	Motor cable connection terminals U2, V2, W2

This figure shows the layout of the power cable connection terminals of frame R11.

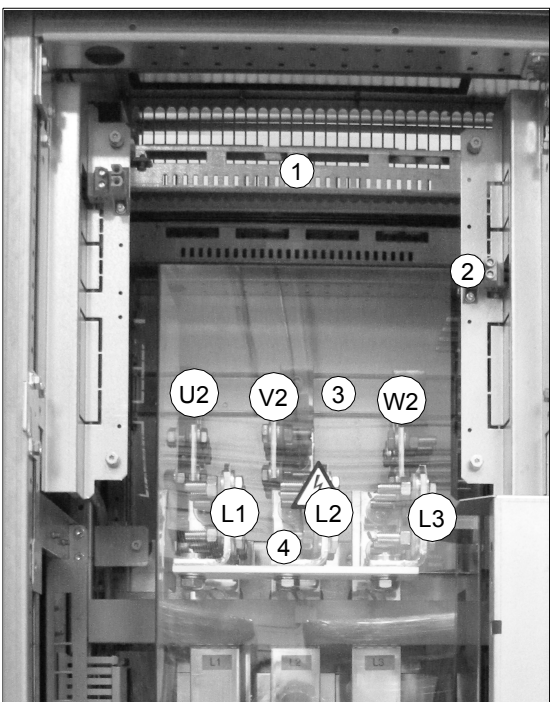

1	Strain relief
2	PE terminal
3	Motor cable connection terminals U2, V2, W2
4	Input cable power connection terminals L1, L2 and L3



## External resistor cable connection terminals and cable entries

External brake resistor cables are connected directly to the brake chopper (option +D150) terminals in the brake chopper cubicle. The delivery drawings show the location of the terminals and entries.

### ■ Connection procedure (IEC)

1. Do the steps in section [Electrical safety precautions](#) on page 19 before you start the work.

2. Open the cabinet door.

3. For R8 bottom entry of cables:

- If there is a mounting plate above the fan, loosen the four screws and pull out the plate. Unplug the connectors and remove the plate.
- If there is no mounting plate, but a shroud above the fan, undo the four screws and remove the shroud.
- Remove the “door fan” (see section [Replacing the cabinet “door fan”](#) on page 174).
- Remove the plastic shroud in front of input terminals.

For R8 top entry of cables:

- Unplug the connectors at the top mounting plate, loosen the four screws and lift off the top mounting plate.
- Remove the plastic shroud in front of input terminals.

For R11 bottom entry of cables:

- If there is a mounting plate/two plates above the fan, loosen the four screws of the plate and pull out the plate/s. Unplug the connectors and remove the plate/s.
- If there is no mounting plate/s, but a shroud/s above the fan, undo the four screws and remove the shroud/s.
- Remove the “door fan” (see section [Replacing the cabinet “door fan”](#) on page 174).
- Marine drives (option +C121): Undo the three M6 screws on the left side of the swing-out frame.
- Undo the two screws and open the swing-out frame or remove the shroud if there is no swing-out frame.
- Remove the plastic shroud in front of input terminals.

For R11 top entry of cables:

- Marine drives (option +C121): Undo the three M6 screws on the left side of the swing-out frame.
- Undo the two screws and open the swing-out frame or remove the shroud if there is no swing-out frame.
- Marine drives (option +C121): Undo the four M6 screws and remove the support in front of top fuse plate.
- Unplug the connectors, loosen the four M6 screws and remove the top fuse plate.

4. Peel off 3 to 5 cm of the outer insulation of the cables above the entry plate for the 360° high-frequency grounding.

5. Prepare the ends of the cables.





**WARNING!** Apply grease to stripped aluminum conductors before attaching them to non-coated aluminum cable lugs. Obey the grease manufacturer's instructions. Aluminum-aluminum contact can cause oxidation in the contact surfaces.

---

6. If fire insulation is used, make an opening in the mineral wool sheet according to the diameter of the cable.
7. Remove rubber grommets from the entry plate for the cables to be connected. Cut adequate holes into the rubber grommets. Slide the grommets onto the cables. Slide the cables through the entry with the conductive sleeves and attach the grommets to the holes.
8. Attach the conductive sleeves to the cable shields with cable ties.
9. Seal the slot between the cable and mineral wool sheet (if used) with sealing compound (eg, CSD-F, ABB brand name DXXT-11, code 35080082).
10. Tie up the unused conductive sleeves with cable ties.
11. Connect the twisted shields of the motor cables to the ground bar and the phase conductors to the U2, V2 and W2 terminals.
12. For drives with external brake resistors (option +D150 and no +D151):
  - Run the power cables from the brake resistors to the brake copper cubicle.
  - Connect the cables as shown in chapter [Resistor braking](#) (page 277).
13. Tighten the power cable screws to the torque given in [Terminal and exit data for the power cables](#) on page 230.
14. Reinstall the shrouds and mounting plates.



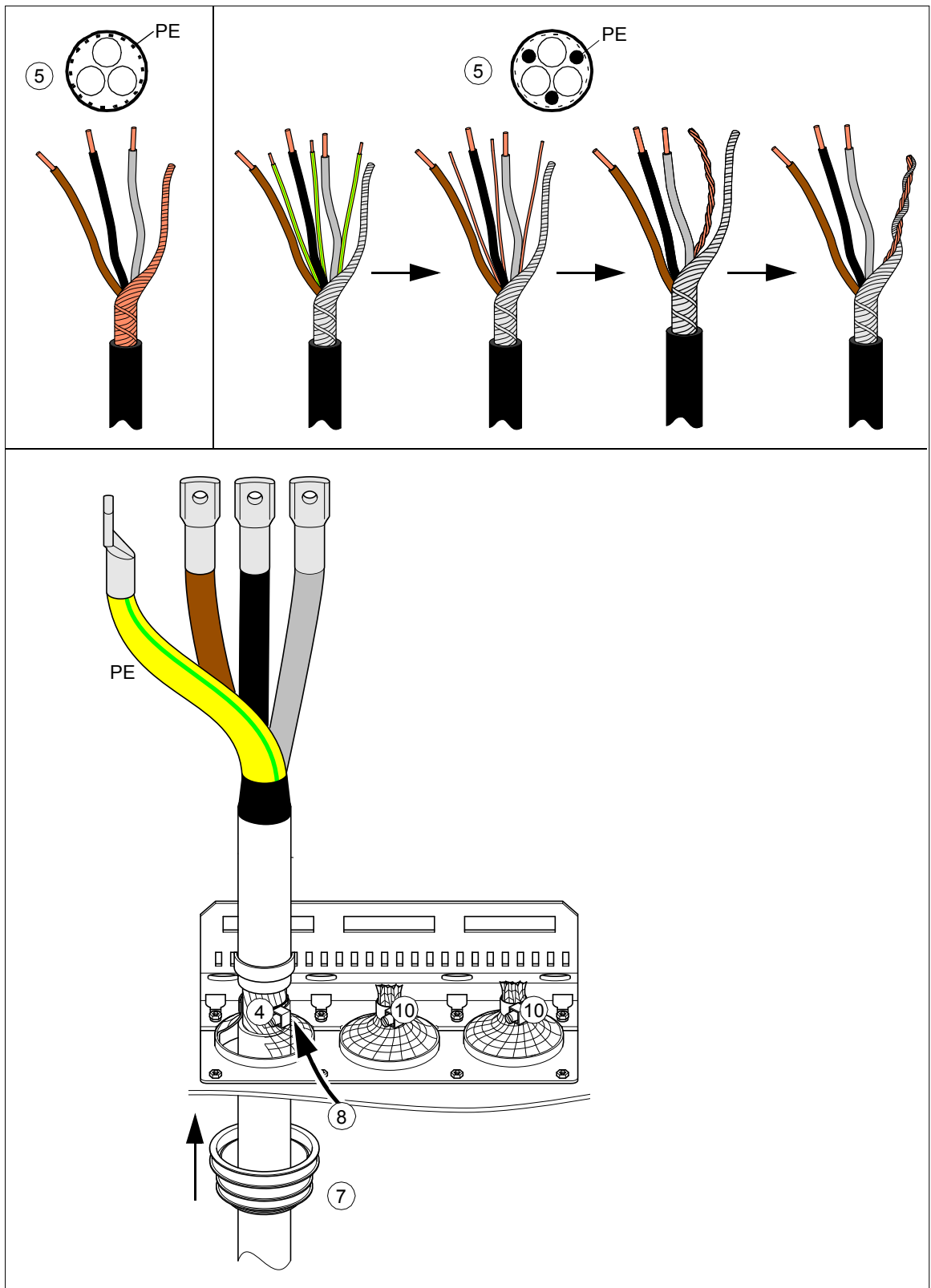

## ■ Connection procedure (US)



**WARNING!** Apply grease to stripped aluminum conductors before attaching them to non-coated aluminum cable lugs. Obey the grease manufacturer's instructions. Aluminum-aluminum contact can cause oxidation in the contact surfaces.

1. Do the steps in section [Electrical safety precautions](#) on page [19](#) before you start the work.
2. Open the cabinet door.
3. For R8 bottom entry of cables:
  - If there is a mounting plate above the fan, loosen the four screws and pull out the plate. Unplug the connectors and remove the plate.
  - If there is no mounting plate, but instead a shroud above the fan, undo the four screws and remove the shroud.
  - Remove the “door” fan (see section [Replacing the cabinet “door fan”](#) on page [174](#)).
  - Remove the plastic cover in front of input terminals.

For R8 top entry of cables:

- Unplug the connectors, loosen the four screws and lift off the top mounting plate.
- Remove the plastic cover in front of input terminals.

For R11 bottom entry of cables:

- If there is a mounting plate/two plates above the fan, loosen the four screws of the plate and pull out the plate/s. Unplug the connectors and remove the plate/s.
- If there is no mounting plate/s, but instead a shroud/s above the fan, undo the four screws and remove the shroud/s.
- Remove the “door” fan (see section [Replacing the cabinet “door fan”](#) on page [174](#)).
- (In marine versions, option +C121, undo the three M6 screws on the left side of the swing-out frame.)
- Undo the two screws and open the swing-out frame or remove the shroud if there is no swing-out frame.
- Remove the plastic cover in front of input terminals.

For R11 top entry of cables:

- (In marine versions, option +C121, undo the three M6 screws on the left side of the swing-out frame.)
- Undo the two screws and open the swing-out frame or remove the shroud if there is no swing-out frame. (In marine versions, option +C121, undo the four M6 screws and remove the support in front of top fuse plate.) Unplug the connectors, loosen the four M6 screws and remove the top fuse plate.



4. Plan cable access and mark the conduit plate accordingly for the input and output power and control cables.
5. Remove the conduit plate from the drive cabinet and cut holes as needed for the conduit connections. **Note:** Never cut metal in or around an equipment cabinet. Metal debris can cause damage to electrical equipment and hazardous conditions.
6. Reinstall the conduit plate to cabinet and connect all electrical conduits as needed to conduit plate. Do not leave any open holes at the top of the cabinet.
7. Run the motor power cables and separate ground cable (if present) from the motor to cabinet.
8. Connect the motor power cable shields and separate ground cable (if present) to the ground bar at the top of the cabinet for top entry and at the bottom of the cabinet if bottom entry (option +H350).
9. Connect the motor phase conductors to the output power terminals U2, V2 and W2.
10. For drives with external brake resistors (option +D150 and no +D151):
  - Run the power cables from the brake resistor to the brake copper cubicle including the grounding cable.
  - Connect the ground cable to the ground bar at the bottom of the cabinet.
  - Connect the brake resistor power cables to the R- and R+ terminals.
11. Make sure that all power is disconnected and reconnection is not possible. Use proper safe disconnect procedures according to local codes.
12. Run the AC power supply cables and separate ground cables (if present) from the supply source to the cabinet.
13. Connect AC power supply cable shields and separate ground cables (if present) to the ground bar at the top of the cabinet for top entry and at the bottom of the cabinet if bottom entry (option +H350).
14. Connect AC supply phase conductors to terminals L1, L2 and L3.
15. Reinstall the shrouds and mounting plates.

### ■ Grounding the motor cable shield at the motor end

Always ground the motor cable shield at the motor end. For minimum radio frequency interference, ground the motor cable shield 360 degrees at the entry of the motor terminal box.

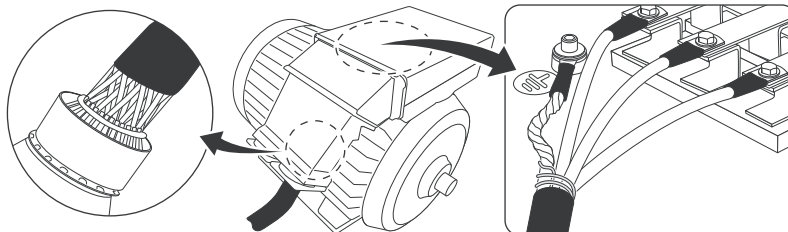

See also [Continuous motor cable shield or enclosure for equipment on the motor cable](#) on page 97.

## Connecting a PC

A PC (with eg. the Drive composer PC tool) can be connected to the drive control unit as follows:

1. Connect the control panel to the drive control unit either by using an Ethernet (eg. CAT5E) networking cable, or by inserting the panel into the panel holder (if present).



**WARNING!** Do not connect the PC directly to the control panel connector of the inverter unit as this can cause damage.

2. Remove the USB connector cover on the front of the control panel.
3. Connect an USB cable (Type A to Type Mini-B) between the USB connector on the control panel (3a) and a free USB port on the PC (3b).
4. The panel will display an indication whenever the connection is active.

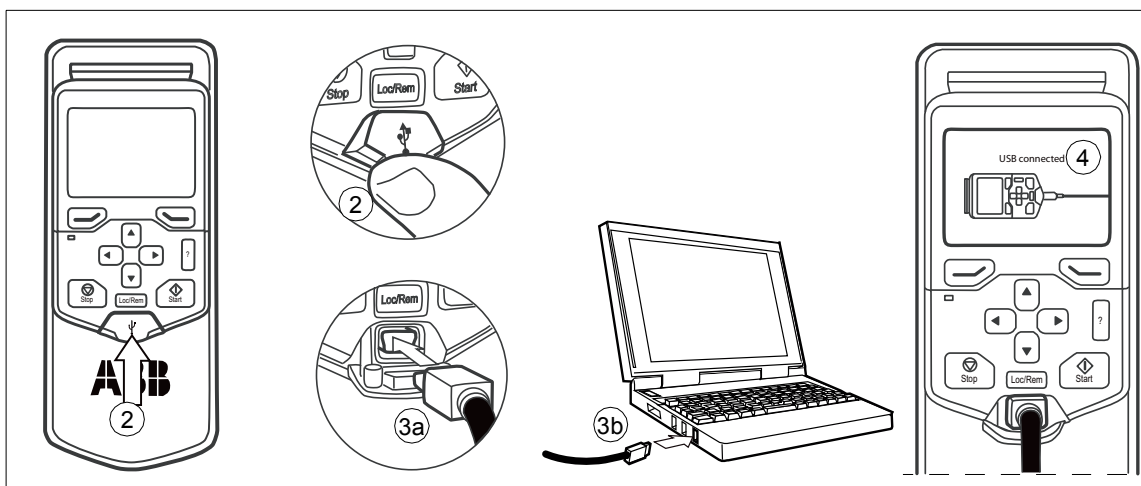

5. See the documentation of the PC tool for setup instructions.

**Note 1:** When a PC is connected to the control panel, the control panel keypad is disabled. In this case, the control panel acts as a USB-RS485 adapter.

## Installing option modules

### ■ Mechanical installation of I/O extension, fieldbus adapter and pulse encoder interface modules

See page 47 for the available slots for each module. Install the option modules as follows:



**WARNING!** Obey the instructions in chapter *Safety instructions*. If you ignore them, injury or death, or damage to the equipment can occur.

1. Stop the drive and do the steps in section *Electrical safety precautions* (page 19) before you start the work.
2. For R8: Open the swing-out frame or remove the shroud if there is no swing-out frame.  
For R11: Open the cabinet door.
3. Insert the module carefully into its position on the control unit (see section *Cabinet layout* on page 38 for the control unit location).
4. Attach the mounting screw. **Note:** The screw tightens the connections and grounds the module. It is essential for fulfilling the EMC requirements and for proper operation of the module.

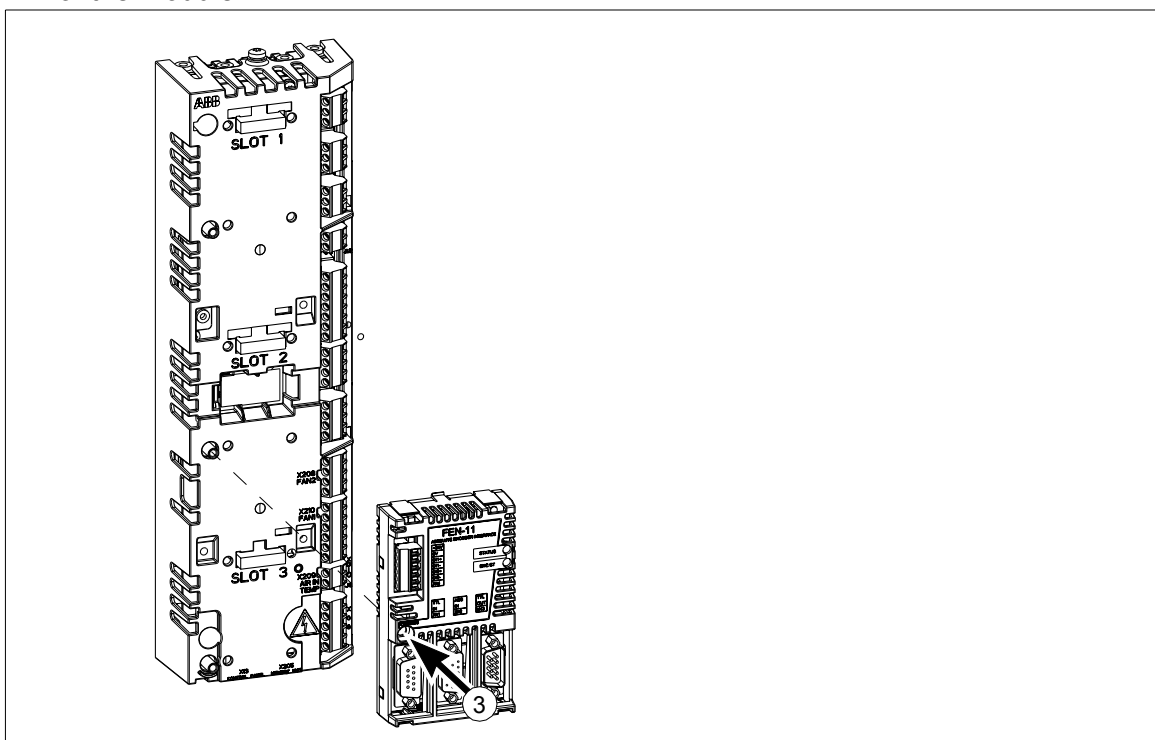

## ■ Installation of safety functions modules (frame R8)

Install the safety functions module next to the ZCU-12 control unit as described below.



**WARNING!** Obey the instructions in chapter [Safety instructions](#). If you ignore them, injury or death, or damage to the equipment can occur.

1. Stop the drive and do the steps in section [Electrical safety precautions](#) (page 19) before you start the work.
2. Open the door.
3. Open the swing-out frame.
4. Insert the module carefully into its position.
5. Attach the module with four screws. **Note:** Correct installation of the module enclosure grounding screw (a) is essential for fulfilling the EMC requirements and for proper operation of the module.
6. Tighten the grounding screw of the electronics to tightening torque 0.8 N·m.
7. Connect the data communication cable to connector X110 on the module and to connector X12 on the drive control unit.
8. Connect the Safe torque off four-wire cable to connector X111 on the module and to connector XSTO on the drive module control unit.
9. Connect the external +24 V power supply cable to connector X112.
10. Connect the other wires as shown in *FSO-12 safety functions module user's manual* (3AXD50000015612 [English]) or *FSO-21 safety functions module user's manual* (3AXD50000015614 [English]).

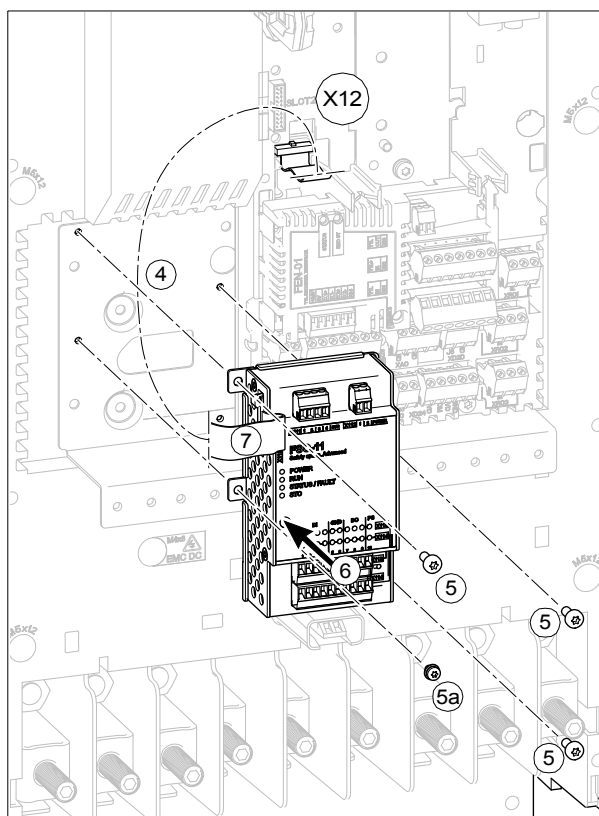



## ■ Installation of safety functions modules (frame R11)

Install the safety functions module next to the ZCU-14 control unit as described below. Change the mounting plate of the module as shown in *FSO-12 safety functions module user's manual* (3AXD50000015612 [English]).



**WARNING!** Obey the instructions in chapter [Safety instructions](#). If you ignore them, injury or death, or damage to the equipment can occur.

---

### Case 1: FSO-xx safety functions module on Slot 2

1. Stop the drive and do the steps in section [Electrical safety precautions](#) (page 19) before you start the work.
2. Open the doors.
3. Connect the FSO-xx data cable to connector X12 on the control unit.
4. Attach the FSO-xx safety functions module to Slot 2 with four screws.
5. Tighten the FSO-xx electronics grounding screw to 0.8 N·m. **Note:** The screw tightens the connections and grounds the module. It is essential for fulfilling the EMC requirements and for proper operation of the module.
6. Connect the FSO-xx data cable to FSO-xx connector X110.
7. Connect the Safe torque off four-wire cable to connector X111 on the module and to connector XSTO on the drive module control unit.
8. Connect the external +24 V power supply cable to connector X112.
9. Connect the other wires as shown in *FSO-12 safety functions module user's manual* (3AXD50000015612 [English]) or *FSO-21 safety functions module user's manual* (3AXD50000015614 [English]).



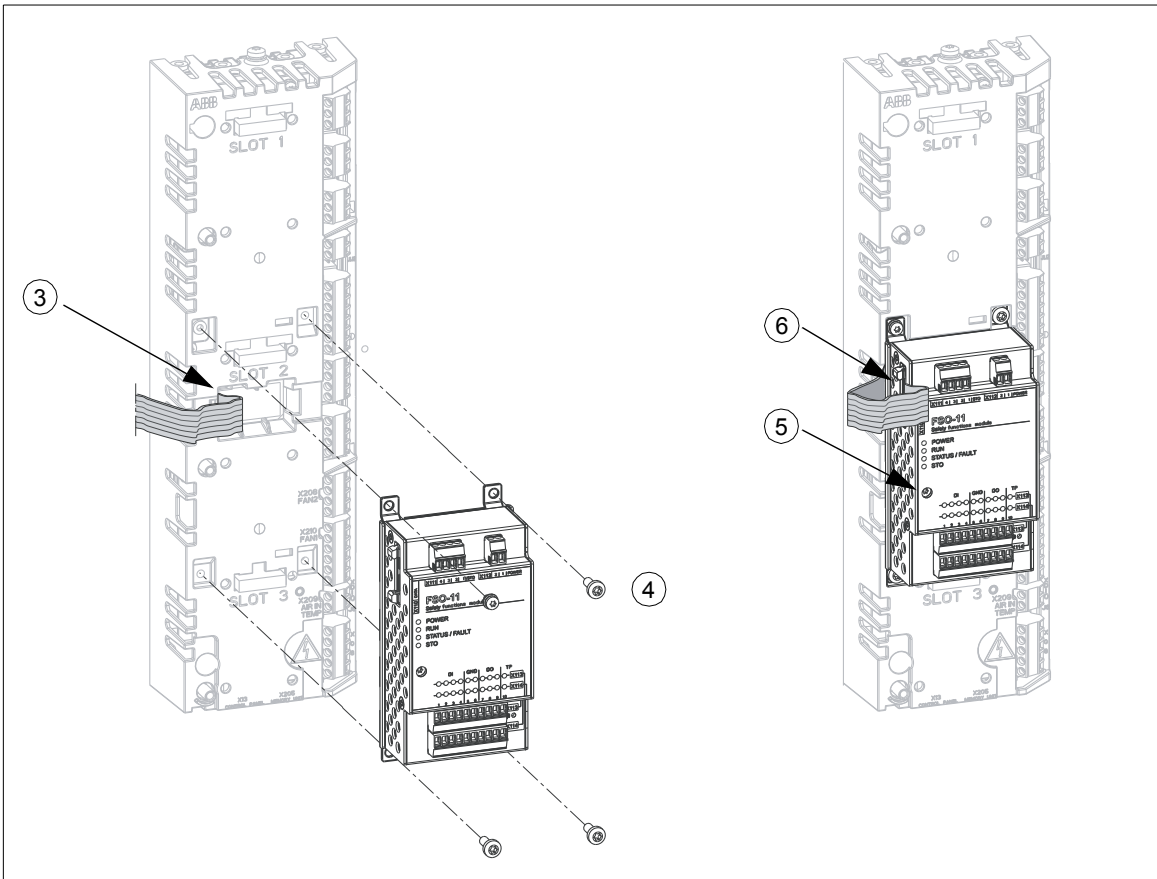

## Case 2: FSO-xx safety functions module next to the control unit

Install the safety functions module next to the control unit as described below. Change the original mounting plate of the module to the alternative plate included in the module package.



**WARNING!** Obey the instructions in chapter [Safety instructions](#). If you ignore them, injury or death, or damage to the equipment can occur.

1. Stop the drive and do the steps in section [Electrical safety precautions](#) (page 19) before you start the work.
2. Open the doors.
3. Attach the FSO-xx safety functions module to the mounting plate with four screws.
4. Tighten the FSO-xx electronics grounding screw to 0.8 N·m. **Note:** The screw tightens the connections and grounds the module. It is essential for fulfilling the EMC requirements and for proper operation of the module.
5. Connect the FSO-xx data cable to FSO-xx connector X110 and to connector X12 on the control unit.

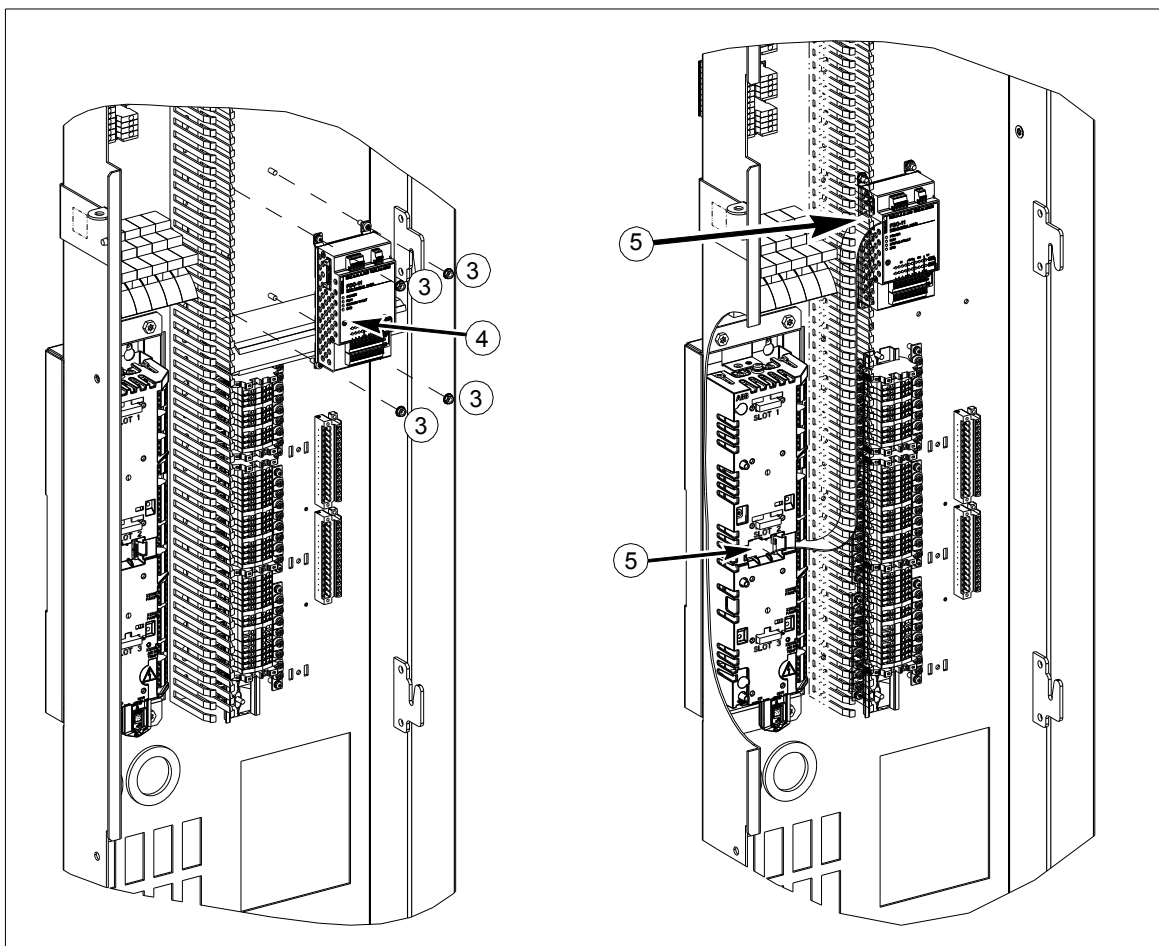



# 7

## Control unit of frame R8

---

### Contents of this chapter

This chapter contains the default I/O connection diagram, descriptions of the terminals and technical data for the control unit (ZCU-12) of drive frame R8.

The ZCU control unit of frame R8 controls the motor-side converter. Control board QCON-21 controls the line-side converter.



## Layout

The layout of external control connection terminals of the control unit is shown below.

<p>The diagram shows the rear panel of the control unit with various connection terminals. Labels are placed over the terminals: XPOW (yellow), XAI (green), XAO (green), XD2D (grey), XRO1 (orange), XRO2 (orange), XRO3 (orange), XD24 (grey), XDIO (blue), XDI (blue), XSTO (yellow), X12 (green), X13 (green), X202 (grey), X203 (grey), X204 (grey), X205 (grey), X208 (grey), J1, J2 (white), J3, J6 (white).</p>	<p><b>Description</b></p> <ul style="list-style-type: none"> <li>XPOW External power input</li> <li>XAI Analog inputs</li> <li>XAO Analog outputs</li> <li>XD2D Drive-to-drive link</li> <li>XRO1 Relay output 1</li> <li>XRO2 Relay output 2</li> <li>XRO3 Relay output 3</li> <li>XD24 Start interlock connection (DIIL) and +24 V output</li> <li>XDIO Digital input/outputs</li> <li>XDI Digital inputs</li> <li>XSTO Safe torque off connection</li> <li>X12 Connector for optional safety functions modules</li> <li>X13 Control panel connection</li> <li>X202 Option slot 1</li> <li>X203 Option slot 2</li> <li>X204 Option slot 3</li> <li>X205 Memory unit connection</li> <li>X208 Auxiliary cooling fan connection</li> <li>J1, J2 Voltage/Current selection jumpers (J1, J2) for analog inputs</li> <li>J3, J6 Drive-to-drive link termination jumper (J3), common digital input ground selection jumper (J6)</li> </ul>
---	--



## Default I/O connection diagram of frame R8

<b>XPOW</b> External power input		
1	+24VI	24 V DC, 2 A
2	GND	
<b>XAI</b> Reference voltage and analog inputs		
1	+VREF	10 V DC, $R_L$ 1...10 kohm
2	-VREF	-10 V DC, $R_L$ 1...10 kohm
3	AGND	Ground
4	AI1+	<b>Speed reference</b> 0(2)...10 V, $R_{in} > 200$ kohm <sup>1)</sup>
5	AI1-	
6	AI2+	By default not in use. 0(4)...20 mA, $R_{in} = 100$ ohm <sup>2)</sup>
7	AI2-	
J1	J1	AI1 current/voltage selection jumper
J2	J2	AI2 current/voltage selection jumper
<b>XAO</b> Analog outputs		
1	AO1	<b>Motor speed rpm</b> 0...20 mA, $R_L < 500$ ohm
2	AGND	
3	AO2	<b>Motor current</b> 0...20 mA, $R_L < 500$ ohm
4	AGND	
<b>XD2D</b> Drive-to-drive link		
1	B	Master/follower, drive-to-drive or embedded fieldbus interface connection
2	A	
3	BGND	
J3	J3	Drive-to-drive link termination switch
<b>XRO1, XRO2, XRO3</b> Relay outputs		
11	NC	<b>Ready</b> 250 V AC / 30 V DC 2 A
12	COM	
13	NO	
21	NC	<b>Running</b> 250 V AC / 30 V DC 2 A
22	COM	
23	NO	
31	NC	<b>Faulted(-1)</b> 250 V AC / 30 V DC 2 A
32	COM	
33	NO	
<b>XD24</b> Digital interlock		
1	DIIL	Run enable
2	+24VD	+24 V DC 200 mA <sup>3)</sup>
3	DICOM	Digital input ground
4	+24VD	+24 V DC 200 mA <sup>3)</sup>
5	DIOGN	Digital input/output ground
J6	J6	Ground selection switch
<b>XDIO</b> Digital input/outputs		
1	DIO1	Output: Ready
2	DIO2	Output: Running
<b>XDI</b> Digital inputs		
1	DI1	Stop (0) / Start (1)
2	DI2	Forward (0) / Reverse (1)
3	DI3	Reset
4	DI4	Acceleration & deceleration select <sup>4)</sup>
5	DI5	Constant speed 1 (1 = On) <sup>5)</sup>
6	DI6	By default not in use.
<b>XSTO</b> Safe torque off		
1	OUT1	Safe torque off. Both circuits must be closed for the drive to start.
2	SGND	
3	IN1	
4	IN2	
<b>X12</b> Safety functions module connection		
<b>X13</b> Control panel connection		
<b>X205</b> Memory unit connection		

Accepted control unit terminal wire sizes: 0.5 ... 2.5 mm<sup>2</sup> (24...14 AWG). Tightening torques: 0.5 N·m (5 lbf·in) for both stranded and solid wiring. For terminal X504 (option +L504), see page 59. See the page 144 for the notes.

**Notes:**









- 1) Current [0(4)...20 mA,  $R_{in} = 100 \text{ ohm}$ ] or voltage [ 0(2)... 10 V,  $R_{in} > 200 \text{ kohm}$ ] input selected with jumper J1. Change of setting requires reboot of control unit.
- 2) Current [0(4)...20 mA,  $R_{in} = 100 \text{ ohm}$ ] or voltage [ 0(2)... 10 V,  $R_{in} > 200 \text{ kohm}$ ] input selected with jumper J2. Change of setting requires reboot of control unit.
- 3) Total load capacity of these outputs is 4.8 W (200 mA / 24 V) minus the power taken by DIO1 and DIO2.
- 4) 0 = open, 1 = closed

D14	Ramp times according to
0	Parameters 23.12 and 23.13
1	Parameters 23.14 and 23.15

- 5) Constant speed 1 is defined by parameter 22.26.

Further information on the usage of the connectors and jumpers is given in the sections below. For the technical data of the connectors, see section [Technical data](#) on page 147.

**Jumpers and switches**

Jumper/Switch	Description	Positions
<b>J1</b> <b>(A11)</b>	Determines whether analog input AI1 is used as a current or voltage input.	 Current (I) ○ ○
		○ Voltage (V) ○ 
<b>J2</b> <b>(A12)</b>	Determines whether analog input AI2 is used as a current or voltage input.	 Current (I) ○ ○
		○ Voltage (U) ○ 
<b>J3</b>	Drive-to-drive link termination. Must be set to terminated position when the drive is the last unit on the link.	 Bus is terminated.
		 Bus is not terminated.
<b>J6</b>	Common digital input ground selection switch. Determines whether DICOM is separated from DIOGND (ie, common reference for digital inputs floats). See the <a href="#">Ground isolation diagram</a> on page 150.	 DICOM and DIOGND connected (default).  DICOM and DIOGND separated.

**External power supply for the control unit (XPOW)**

External +24 V (2 A) power supply for the control unit can be connected to terminal block XPOW. Using an external supply is recommended if

- the control unit needs to be kept operational during input power breaks, for example, due to uninterrupted fieldbus communication
- immediate restart is needed after power breaks (that is, no control unit power up delay is allowed).

See also the firmware manual, parameter 95.04.





## ■ AI1 and AI2 as Pt100, Pt1000, PTC and KTY84 sensor inputs (XAI, XAO)

Three Pt100/Pt1000 or PTC sensors or one KTY84 sensor for motor temperature measurement can be connected between an analog input and output as shown below. (Alternatively, you can connect the KTY to FIO-11 or FAIO-01 analog I/O extension module or FEN-xx encoder interface module.) At the sensor end of the cable, leave the shields unconnected or ground them indirectly via a high-frequency capacitor with a few nanofarads, eg. 3.3 nF / 630 V. The shield can also be grounded directly at both ends if they are in the same ground line with no significant voltage drop between the end points.

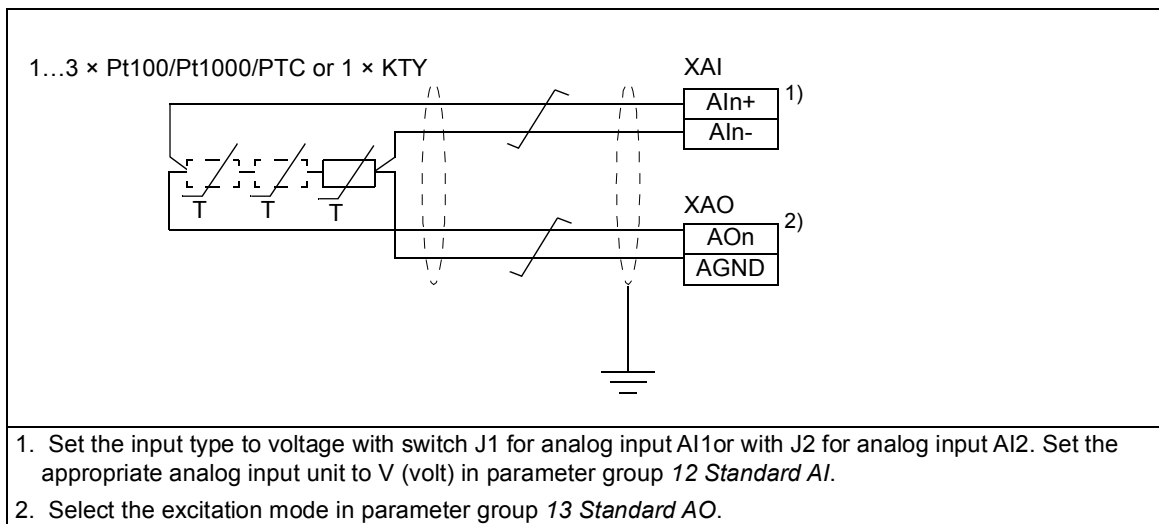

**WARNING!** As the inputs pictured above are not insulated according to IEC/EN 60664, the connection of the motor temperature sensor requires double or reinforced insulation between motor live parts and the sensor. If the assembly does not fulfill the requirement, the I/O board terminals must be protected against contact and must not be connected to other equipment or the temperature sensor must be isolated from the I/O terminals.



## ■ DI6 (XDI:6) as PTC sensor input

A PTC sensor can be connected to this input for motor temperature measurement as follows. The sensor resistance must not exceed the threshold resistance of the digital input at the motor normal operating temperature. Do not connect both ends of the cable shield directly to ground. Leave the other end of the shield unconnected or ground it directly via a few nanofarads high-frequency capacitor, for example, 3.3 nF / 630 V. The shield can also be grounded directly at both ends if they are in the same ground line with no significant voltage drop between the end points. See the firmware manual for parameter settings.

**Note:** PTC sensors can alternatively be connected to FEN-xx encoder interface module.

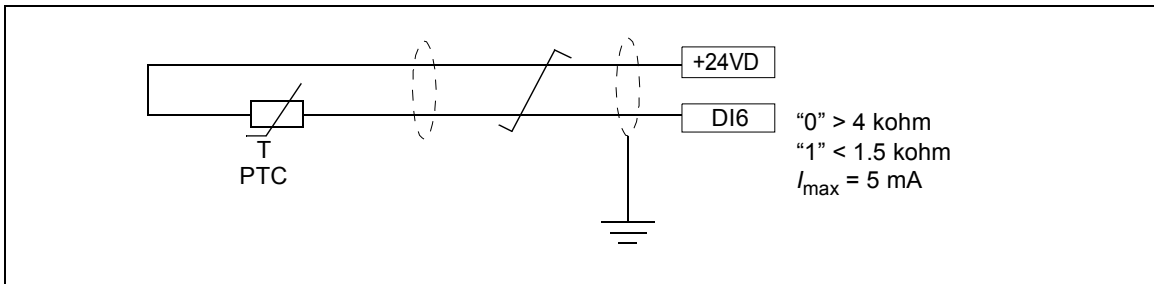

**WARNING!** As the inputs pictured above are not insulated according to IEC/EN 60664, the connection of the motor temperature sensor requires double or reinforced insulation between motor live parts and the sensor. If the assembly does not fulfill the requirement, the I/O board terminals must be protected against contact and must not be connected to other equipment or the temperature sensor must be isolated from the I/O terminals.

## ■ DIIL input (XD24:1)

The DIIL input can be selected as the source of, for example, an emergency stop command or an external event. For more information, see the firmware manual.

## ■ The XD2D connector

The XD2D connector provides an RS-485 connection that can be used for

- basic master/follower communication with one master drive and multiple followers,
- fieldbus control through the embedded fieldbus interface (EFB), or
- drive-to-drive (D2D) communication implemented by application programming.

See the firmware manual of the drive for the related parameter settings.

Enable bus termination on the units at the ends of the drive-to-drive link. Disable bus termination on the intermediate units.

Use shielded twisted-pair cable with a twisted pair for data and a wire or another pair for signal ground (nominal impedance 100 to 165 ohm, for example Belden 9842) for the wiring. For best immunity, ABB recommends high quality cable. Keep the cable as short as possible. Avoid unnecessary loops and parallel runs near power cables such as motor cables.

The following diagram shows the wiring between control units for frame R8.

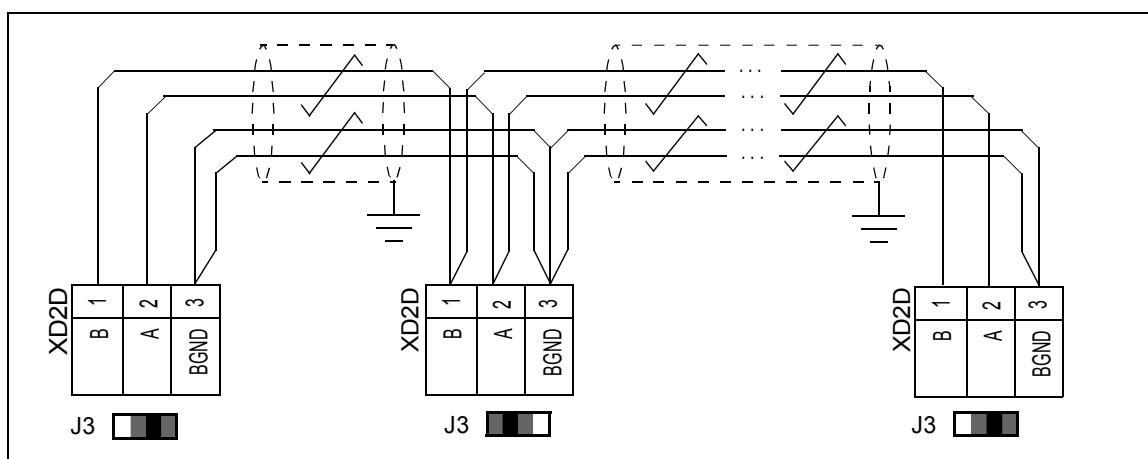

### ■ Safe torque off (XSTO)

For the drive to start, both connections (OUT1 to IN1 and IN2) must be closed. By default, the terminal block has jumpers to close the circuit. Remove the jumpers before connecting an external Safe torque off circuit to the drive. For information on the implementation of a Safe torque off function, see chapter [The Safe torque off function](#) on page 265.

### ■ FSO-xx safety functions module connection (X12)

See section [Implementing the functions provided by the FSO-xx safety functions module \(option +Q972 or +Q973\)](#) on page 99, chapter [The Safe torque off function](#) and [FSO-12 safety functions module user's manual \(3AXD50000015612 \[English\]\)](#) or [FSO-21 safety functions module user's manual \(3AXD50000015614 \[English\]\)](#).

## Technical data

### Power supply (XPOW)

Connector pitch 5 mm (0.2 in), wire size 2.5 mm<sup>2</sup> (14 AWG)  
24 V (±10%) DC, 2 A  
Supplied from the power unit of the drive, or from an external power supply through connector XPOW. Connector pitch 5 mm (0.2 in), wire size 2.5 mm<sup>2</sup> (14 AWG).

### Relay outputs RO1...RO3 (XRO1 ... XRO3)

Connector pitch 5 mm (0.2 in), wire size 2.5 mm<sup>2</sup> (14 AWG)  
250 V AC / 30 V DC, 2 A  
Protected by varistors

### +24 V output (XD24:2 and XD24:4)

Connector pitch 5 mm (0.2 in), wire size 2.5 mm<sup>2</sup> (14 AWG)  
Total load capacity of these outputs is 4.8 W (200 mA / 24 V) minus the power taken by DIO1 and DIO2.

### Digital inputs DI1...DI6 (XDI:1 ... XDI:6)

Connector pitch 5 mm (0.2 in), wire size 2.5 mm<sup>2</sup> (14 AWG)  
24 V logic levels: "0" < 5 V, "1" > 15 V  
 $R_{in}$ : 2.0 kohm  
Input type: NPN/PNP (DI1...DI5), NPN (DI6)  
Hardware filtering: 0.04 ms, digital filtering up to 8 ms  
DI6 (XDI:6) can alternatively be used as an input for PTC sensors.  
"0" > 4 kohm, "1" < 1.5 kohm  
 $I_{max}$ : 15 mA (for DI6 5 mA)

### Start interlock input DIIL (XD24:1)

Connector pitch 5 mm (0.2 in), wire size 2.5 mm<sup>2</sup> (14 AWG)  
24 V logic levels: "0" < 5 V, "1" > 15 V  
 $R_{in}$ : 2.0 kohm  
Input type: NPN/PNP  
Hardware filtering: 0.04 ms, digital filtering up to 8 ms



**Digital inputs/outputs DIO1 and DIO2**

(XDIO:1 and XDIO:2)  
Input/output mode selection by parameters.

DIO1 can be configured as a frequency input (0...16 kHz with hardware filtering of 4 microseconds) for 24 V level square wave signal (sinusoidal or other wave form cannot be used). DIO2 can be configured as a 24 V level square wave frequency output. See the firmware manual, parameter group 11.

Connector pitch 5 mm (0.2 in), wire size 2.5 mm<sup>2</sup> (14 AWG)

As inputs:

24 V logic levels: "0" < 5 V, "1" > 15 V

R<sub>in</sub>: 2.0 kohm

Filtering: 0.25 ms

As outputs:

Total output current from +24VD is limited to 200 mA.

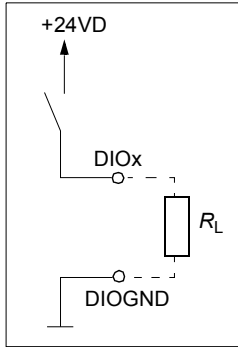

**Reference voltage for analog inputs +VREF and -VREF**  
(XAI:1 and XAI:2)

**Analog inputs AI1 and AI2**  
(XAI:4 ... XAI:7).

Current/voltage input mode selection by jumpers. See page 144.

Connector pitch 5 mm (0.2 in), wire size 2.5 mm<sup>2</sup> (14 AWG)

10 V ±1% and -10 V ±1%, R<sub>load</sub> 1...10 kohm

Connector pitch 5 mm (0.2 in), wire size 2.5 mm<sup>2</sup> (14 AWG)

Current input: -20...20 mA, R<sub>in</sub>: 100 ohm

Voltage input: -10...10 V, R<sub>in</sub>: > 200 kohm

Differential inputs, common mode range ±30 V

Sampling interval per channel: 0.25 ms

Hardware filtering: 0.25 ms, adjustable digital filtering up to 8 ms

Resolution: 11 bit + sign bit

Inaccuracy: 1% of full scale range

Inaccuracy for Pt100 sensors: 10 °C (50 °F)

**Analog outputs AO1 and AO2**  
(XAO)

Connector pitch 5 mm (0.2 in), wire size 2.5 mm<sup>2</sup> (14 AWG)

0...20 mA, R<sub>load</sub> < 500 ohm

Frequency range: 0...300 Hz

Resolution: 11 bit + sign bit

Inaccuracy: 2% of full scale range

**Drive to drive link**  
(XD2D)

Connector pitch 5 mm, wire size 2.5 mm<sup>2</sup>

Physical layer: RS-485

Maximum cable length of the link: 50 m

Cable type: Shielded twisted pair cable with twisted pair for data and a wire or pair for signal ground, nominal impedance 100...165 ohm, for example Belden 9842

Transmission rate: 8 Mbit/s

Termination by switch

**Embedded Modbus RTU**  
(XD2D)

Connector pitch 5 mm, wire size 2.5 mm<sup>2</sup>

Physical layer: RS-485

Cable type: Shielded twisted pair cable with twisted pair for data and a wire or pair for signal ground, nominal impedance 100...165 ohm, for example Belden 9842

Transmission rate: 9.6...115.2 kbit/s

Termination by switch

**Safe torque off connection**  
(XSTO)

Connector pitch 5 mm (0.2 in), wire size 2.5 mm<sup>2</sup> (14 AWG)

Input voltage range: -3...30 V DC

Logic levels: "0" < 5 V, "1" > 17 V

For the drive to start, both connections must be closed (OUT1 to IN1 and IN2).

Current consumption of frame R8: 12 mA (+24 V DC, continuous) per STO channel

Maximum output current from OUT1 (24 V DC continuous): 100 mA

EMC (immunity) according to IEC 61326-3-1



**Control panel / PC  
connection**

Connector: RJ-45  
Cable length < 3 m (10 ft)

The terminals of the control unit fulfill the Protective Extra Low Voltage (PELV) requirements. The PELV requirements of a relay output are not fulfilled if a voltage higher than 48 V is connected to the relay output.



**Ground isolation diagram**

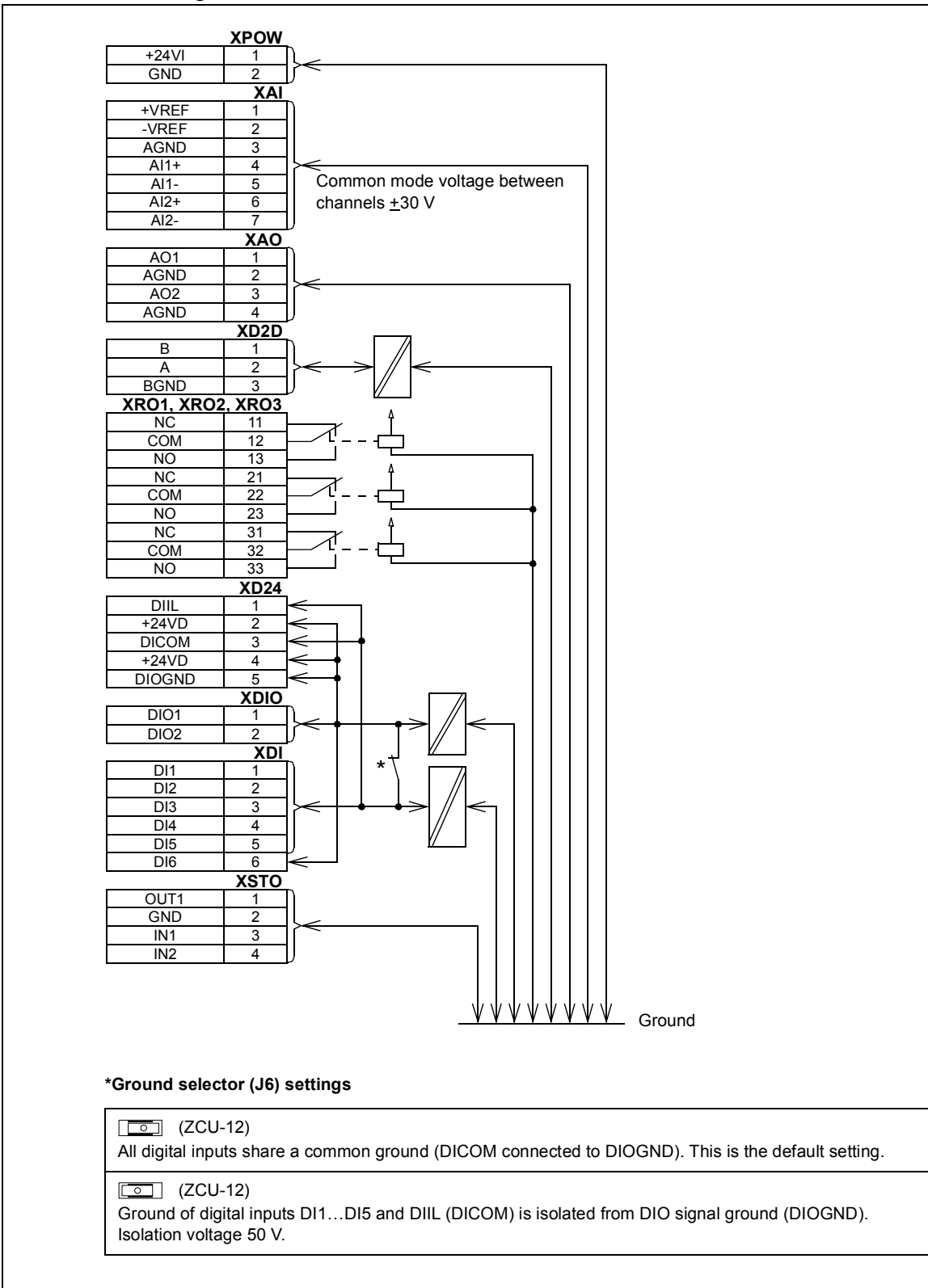

# 8

## Control unit of frame R11

---

### Contents of this chapter

This chapter contains the default I/O connection diagram, descriptions of the terminals and technical data for the control unit (ZCU-14).

Frame R11 contains two ZCU control units. One controls the line-side converter, the other the motor-side converter.



## Layout

The layout of the external control connection terminals of the control unit is shown below.

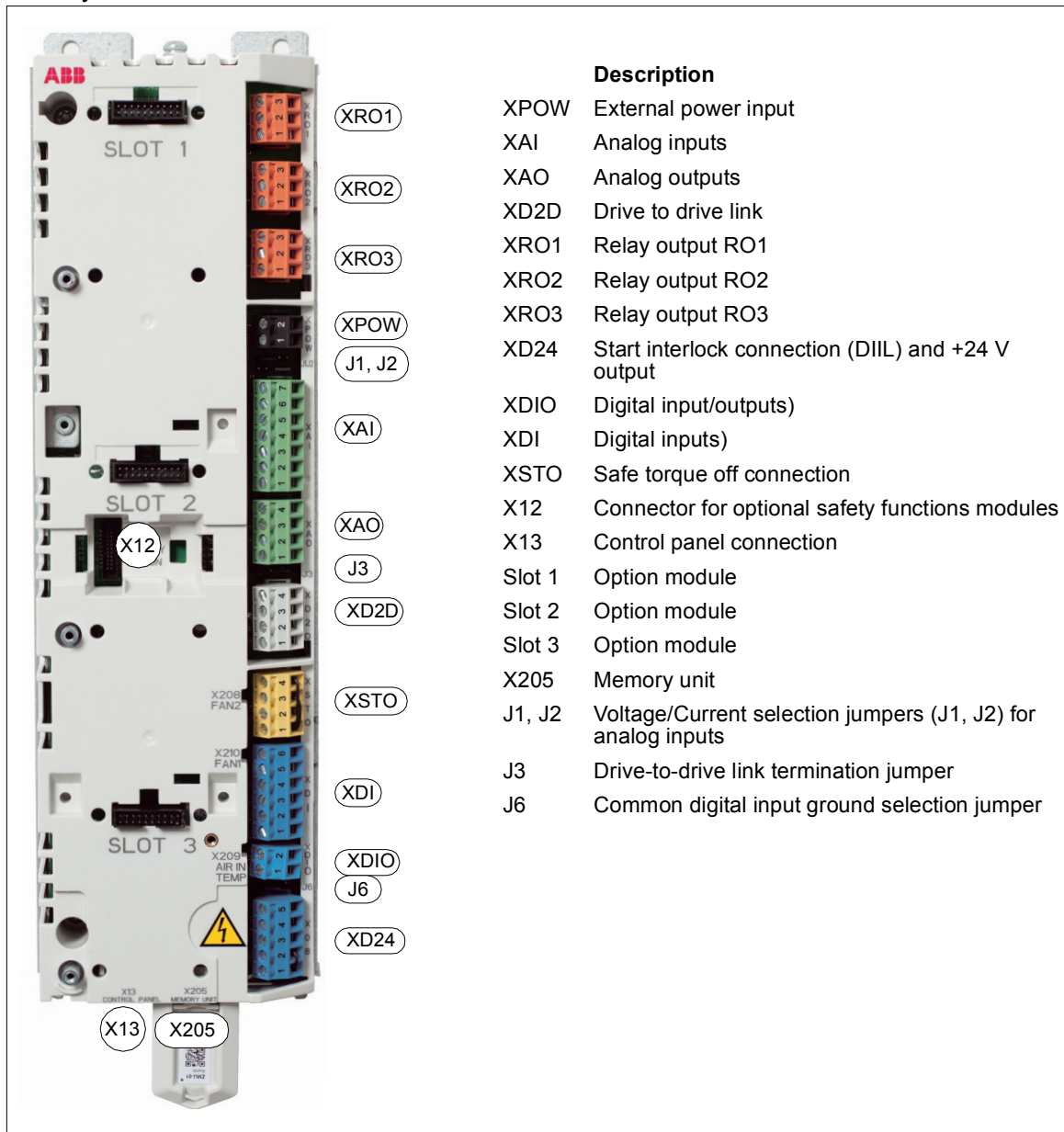

The diagram shows the front panel of an ABB control unit with three slots (SLOT 1, SLOT 2, SLOT 3) and various connection terminals. A screwdriver icon is present in the bottom left corner. The terminals are color-coded: orange for power and relay outputs, green for digital I/O, yellow for fan connections, and blue for digital I/O. A warning symbol is located near the bottom of the unit.

Terminal Label	Description
XRO1	External power input
XAI	Analog inputs
XAO	Analog outputs
XD2D	Drive to drive link
XRO1	Relay output RO1
XRO2	Relay output RO2
XRO3	Relay output RO3
XPOW	Start interlock connection (DIIL) and +24 V output
J1, J2	
XAI	Digital input/outputs)
XDI	Digital inputs)
XSTO	Safe torque off connection
X12	Connector for optional safety functions modules
X13	Control panel connection
J3	Option module
XD2D	Option module
XSTO	Option module
X205	Memory unit
J1, J2	Voltage/Current selection jumpers (J1, J2) for analog inputs
J3	Drive-to-drive link termination jumper
J6	Common digital input ground selection jumper
XDI	
XDIO	
J6	
XD24	



## Default I/O connection diagram of frame R11

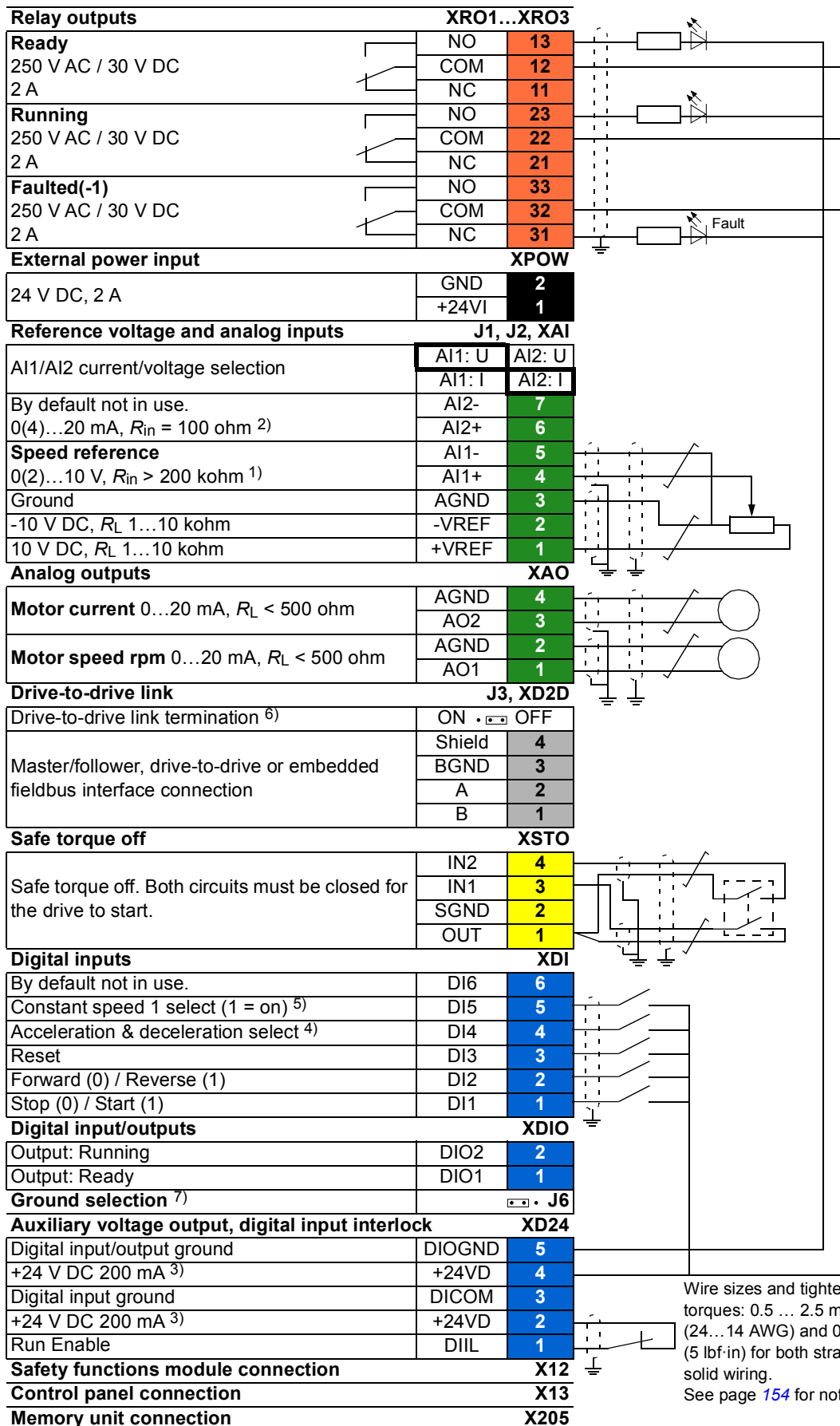

**Notes:**









- 1) Current [0(4)...20 mA,  $R_{in} = 100 \text{ ohm}$ ] or voltage [0(2)...10 V,  $R_{in} > 200 \text{ kohm}$ ] input selected with jumper J1. Change of setting requires reboot of control unit.
- 2) Current [0(4)...20 mA,  $R_{in} = 100 \text{ ohm}$ ] or voltage [0(2)...10 V,  $R_{in} > 200 \text{ kohm}$ ] input selected with jumper J2. Change of setting requires reboot of control unit.
- 3) Total load capacity of these outputs is 4.8 W (200 mA / 24 V) minus the power taken by tDIO1 and DIO2.
- 4) 0 = open, 1 = closed

D14	Ramp times according to
0	Parameters 23.12 and 23.13
1	Parameters 23.14 and 23.15

- 5) Constant speed 1 is defined by parameter 22.26.
- 6) Must be set to ON when the drive is the last unit on the drive-to-drive (D2D) link.
- 7) Determines whether DICOM is separated from DIOGND (ie. common reference for digital inputs floats).  
 • DICOM connected to DIOGND. •  DICOM and DIOGND separate

Further information on the usage of the connectors and jumpers is given in the sections below.

**Jumpers and switches**

Jumper/Switch	Description	Positions
<b>J1 (A11)</b>	Determines whether analog input AI1 is used as a current or voltage input.	 Current (I) ○ ○
		○ Voltage (V) ○ 
<b>J2 (A12)</b>	Determines whether analog input AI2 is used as a current or voltage input.	 Current (I) ○ ○
		○ Voltage (U) ○ 
<b>J3</b>	Drive-to-drive link termination. Must be set to terminated position when the drive is the last unit on the link.	 Bus is terminated.
		 Bus is not terminated.
<b>J6</b>	Common digital input ground selection switch. Determines whether DICOM is separated from DIOGND (ie, common reference for digital inputs floats). See the <a href="#">Ground isolation diagram</a> on page 159.	 DICOM and DIOGND connected (default).  DICOM and DIOGND separated.

**External power supply for the control unit (XPOW)**

External +24 V (2 A) power supply for the control unit can be connected to terminal block XPOW. Using an external supply is recommended if

- the control unit needs to be kept operational during input power breaks, for example, due to uninterrupted fieldbus communication
- immediate restart is needed after power breaks (that is, no control unit power up delay is allowed).

See also the firmware manual, parameter 95.04.

## ■ AI1 and AI2 as Pt100, Pt1000, PTC and KTY84 sensor inputs (XAI, XAO)

Three Pt100, Pt1000 or PTC sensors or one KTY84 sensor for motor temperature measurement can be connected between an analog input and output as shown below. (Alternatively, you can connect the KTY to FIO-11 analog I/O extension module or FEN-xx encoder interface module.) Do not connect both ends of the cable shields directly to ground. If a high-frequency capacitor of a few nanofarads, eg. 3.3.nF / 630 V, cannot be used at one end, leave that end of the shield unconnected.

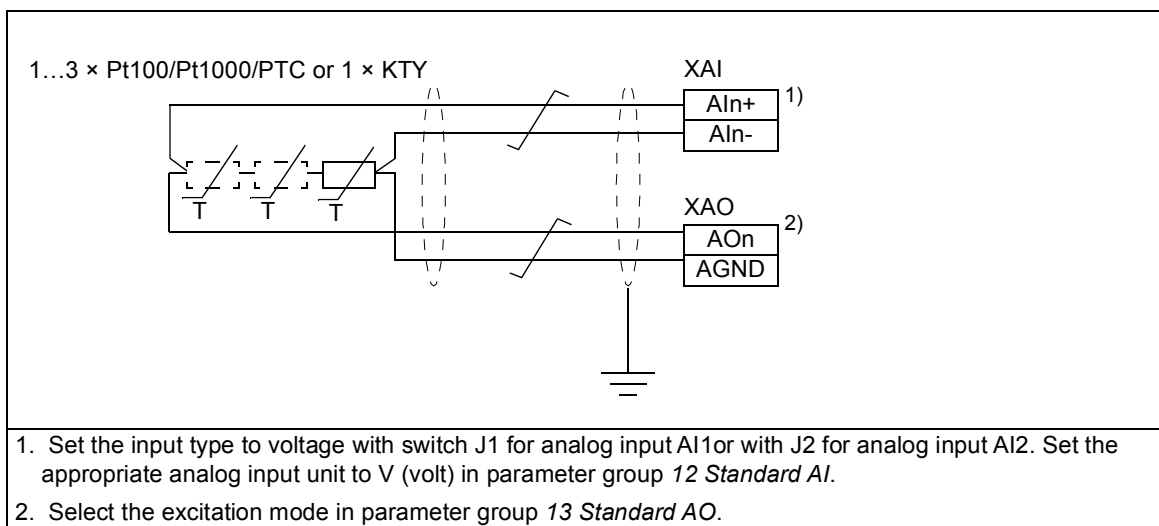

**WARNING!** As the inputs pictured above are not insulated according to IEC 60664, the connection of the motor temperature sensor requires double or reinforced insulation between motor live parts and the sensor. If the assembly does not fulfill the requirement, the I/O board terminals must be protected against contact and must not be connected to other equipment or the temperature sensor must be isolated from the I/O terminals.



## ■ DI6 (XDI:6) as PTC sensor input

A PTC sensor can be connected to this input for motor temperature measurement as follows. The sensor resistance must not exceed the threshold resistance of the digital input at the motor normal operating temperature. Do not connect both ends of the cable shield directly to ground. If a high-frequency capacitor of a few nanofarads, eg. 3.3.nF / 630 V, cannot be used at one end, leave that end of the shield unconnected. See the firmware manual for parameter settings.

**Note:** PTC sensors can alternatively be connected to FEN-xx encoder interface module.

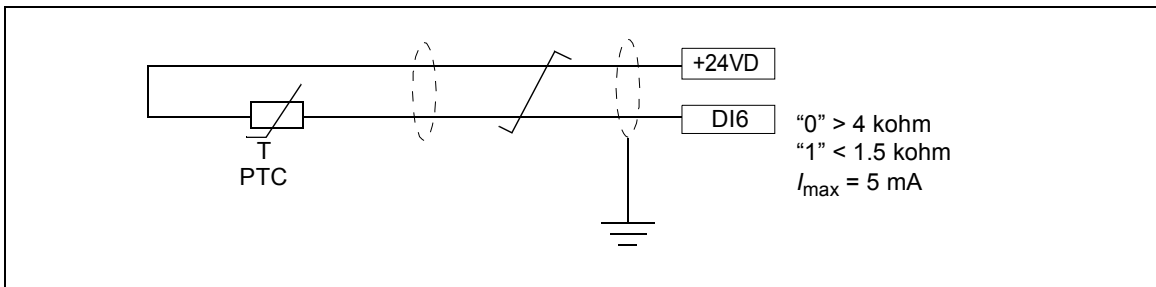

**WARNING!** As the inputs pictured above are not insulated according to IEC 60664, the connection of the motor temperature sensor requires double or reinforced insulation between motor live parts and the sensor. If the assembly does not fulfill the requirement, the I/O board terminals must be protected against contact and must not be connected to other equipment or the temperature sensor must be isolated from the I/O terminals.

## ■ DIIL input (XD24:1)

The DIIL input can be selected as the source of, for example, an emergency stop command or an external event. For more information, see the firmware manual.

## ■ The XD2D connector

The XD2D connector provides an RS-485 connection that can be used for

- basic master/follower communication with one master drive and multiple followers,
- fieldbus control through the embedded fieldbus interface (EFB), or
- drive-to-drive (D2D) communication implemented by application programming.

See the firmware manual of the drive for the related parameter settings.

Enable bus termination on the units at the ends of the drive-to-drive link. Disable bus termination on the intermediate units.

Use shielded twisted-pair cable with a twisted pair for data and a wire or another pair for signal ground (nominal impedance 100 to 165 ohm, for example Belden 9842) for the wiring. For best immunity, ABB recommends high quality cable. Keep the cable as short as possible. Avoid unnecessary loops and parallel runs near power cables such as motor cables.

The following diagram shows the wiring between control units for frame R11.

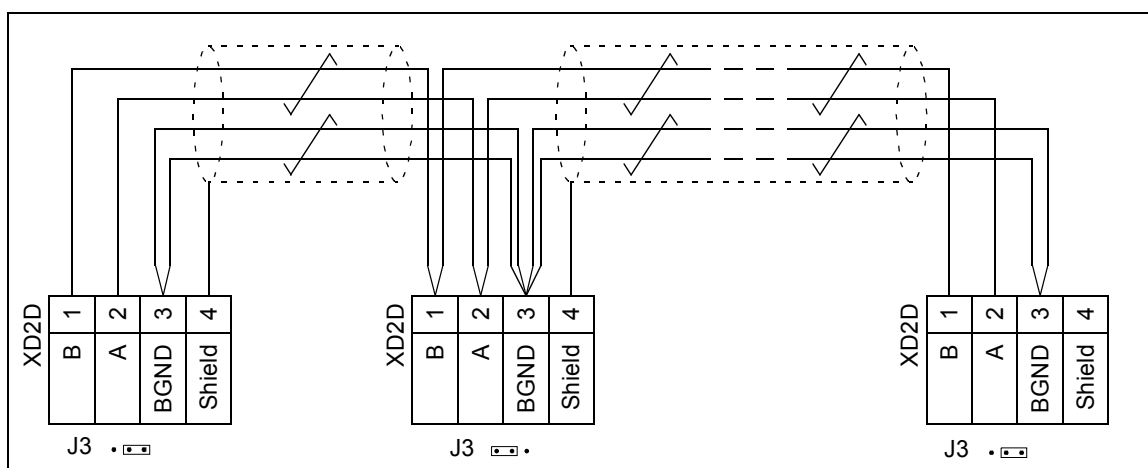

### ■ Safe torque off (XSTO)

For the drive to start, both connections (OUT1 to IN1 and IN2) must be closed. By default, the terminal block has jumpers to close the circuit. Remove the jumpers before connecting an external Safe torque off circuitry to the drive. See chapter [The Safe torque off function](#) on page 265.

### ■ FSO-xx safety functions module connection (X12)

See section [Implementing the functions provided by the FSO-xx safety functions module \(option +Q972 or +Q973\)](#) on page 99, chapter [The Safe torque off function](#) and [FSO-12 safety functions module user's manual \(3AXD50000015612 \[English\]\)](#) or [FSO-21 safety functions module user's manual \(3AXD50000015614 \[English\]\)](#).

## Technical data

<b>Power supply (XPOW)</b>	24 V ( $\pm 10\%$ ) DC, 2 A Supplied from the power unit of the drive, or from an external power supply through connector XPOW. Connector pitch 5 mm (0.2 in), wire size 2.5 mm <sup>2</sup> (14 AWG).
<b>Relay outputs RO1...RO3 (XRO1 ... XRO3)</b>	Connector pitch 5 mm (0.2 in), wire size 2.5 mm <sup>2</sup> (14 AWG) 250 V AC / 30 V DC, 2 A Protected by varistors
<b>+24 V output (XD24:2 and XD24:4)</b>	Connector pitch 5 mm (0.2 in), wire size 2.5 mm <sup>2</sup> (14 AWG) Total load capacity of these outputs is 4.8 W (200 mA / 24 V) minus the power taken by DIO1 and DIO2.
<b>Digital inputs DI1...DI6 (XDI:1 ... XDI:6)</b>	Connector pitch 5 mm (0.2 in), wire size 2.5 mm <sup>2</sup> (14 AWG) 24 V logic levels: "0" < 5 V, "1" > 15 V $R_{in}$ : 2.0 kohm Input type: NPN/PNP (DI1...DI5), NPN (DI6) Hardware filtering: 0.04 ms, digital filtering up to 8 ms DI6 (XDI:6) can alternatively be used as an input for PTC sensors. "0" > 4 kohm, "1" < 1.5 kohm $I_{max}$ : 15 mA (for DI6 5 mA)
<b>Start interlock input DIIL (XD24:1)</b>	Connector pitch 5 mm (0.2 in), wire size 2.5 mm <sup>2</sup> (14 AWG) 24 V logic levels: "0" < 5 V, "1" > 15 V $R_{in}$ : 2.0 kohm Input type: NPN/PNP Hardware filtering: 0.04 ms, digital filtering up to 8 ms



**Digital inputs/outputs DIO1 and DIO2****(XDIO:1 and XDIO:2)**

Input/output mode selection by parameters.

DIO1 can be configured as a frequency input (0...16 kHz with hardware filtering of 4 microseconds) for 24 V level square wave signal (sinusoidal or other wave form cannot be used). DIO2 can be configured as a 24 V level square wave frequency output. See the firmware manual, parameter group 11.

Connector pitch 5 mm (0.2 in), wire size 2.5 mm<sup>2</sup> (14 AWG)As inputs:

24 V logic levels: "0" &lt; 5 V, "1" &gt; 15 V

 $R_{in}$ : 2.0 kohm

Filtering: 0.25 ms

As outputs:

Total output current from +24VD is limited to 200 mA.

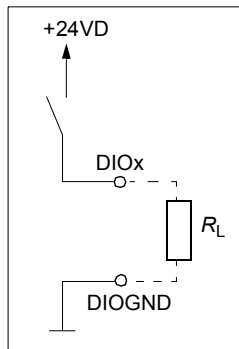
**Reference voltage for analog inputs +VREF and -VREF****(XAI:1 and XAI:2)****Analog inputs AI1 and AI2****(XAI:4 ... XAI:7).**

Current/voltage input mode selection by jumpers. See page 154.

Connector pitch 5 mm (0.2 in), wire size 2.5 mm<sup>2</sup> (14 AWG)10 V ±1% and -10 V ±1%,  $R_{load}$  1...10 kohmConnector pitch 5 mm (0.2 in), wire size 2.5 mm<sup>2</sup> (14 AWG)Current input: -20...20 mA,  $R_{in}$ : 100 ohmVoltage input: -10...10 V,  $R_{in}$ : > 200 kohm

Differential inputs, common mode range ±30 V

Sampling interval per channel: 0.25 ms

Hardware filtering: 0.25 ms, adjustable digital filtering up to 8 ms

Resolution: 11 bit + sign bit

Inaccuracy: 1% of full scale range

Inaccuracy for Pt100 sensors: 10 °C (50 °F)

**Analog outputs AO1 and AO2****(XAO)**Connector pitch 5 mm (0.2 in), wire size 2.5 mm<sup>2</sup> (14 AWG)0...20 mA,  $R_{load}$  < 500 ohm

Frequency range: 0...300 Hz

Resolution: 11 bit + sign bit

Inaccuracy: 2% of full scale range

**Drive to drive link****(XD2D)**Connector pitch 5 mm, wire size 2.5 mm<sup>2</sup>

Physical layer: RS-485

Maximum cable length of the link: 50 m

Cable type: Shielded twisted pair cable with twisted pair for data and a wire or pair for signal ground, nominal impedance 100...165 ohm, for example Belden 9842

Transmission rate: 8 Mbit/s

Termination by switch

**Embedded Modbus RTU****XD2D**Connector pitch 5 mm, wire size 2.5 mm<sup>2</sup>

Physical layer: RS-485

Cable type: Shielded twisted pair cable with twisted pair for data and a wire or pair for signal ground, nominal impedance 100...165 ohm, for example Belden 9842

Transmission rate: 9.6...115.2 kbit/s

Termination by switch

**Safe torque off connection****(XSTO)**Connector pitch 5 mm (0.2 in), wire size 2.5 mm<sup>2</sup> (14 AWG)

Input voltage range: -3...30 V DC

Logic levels: "0" &lt; 5 V, "1" &gt; 19 V

For the drive to start, both connections must be closed (OUT1 to IN1 and IN2).

Current consumption: 50 mA (+24 V DC, continuous) per STO channel.

EMC (immunity) according to IEC 61326-3-1

**Control panel / PC connection**

Connector: RJ-45

Cable length &lt; 3 m (10 ft)



The terminals on the board fulfill the Protective Extra Low Voltage (PELV) requirements. The PELV requirements of a relay output are not fulfilled if the relay is used with a voltage higher than 48 V.

**Ground isolation diagram**

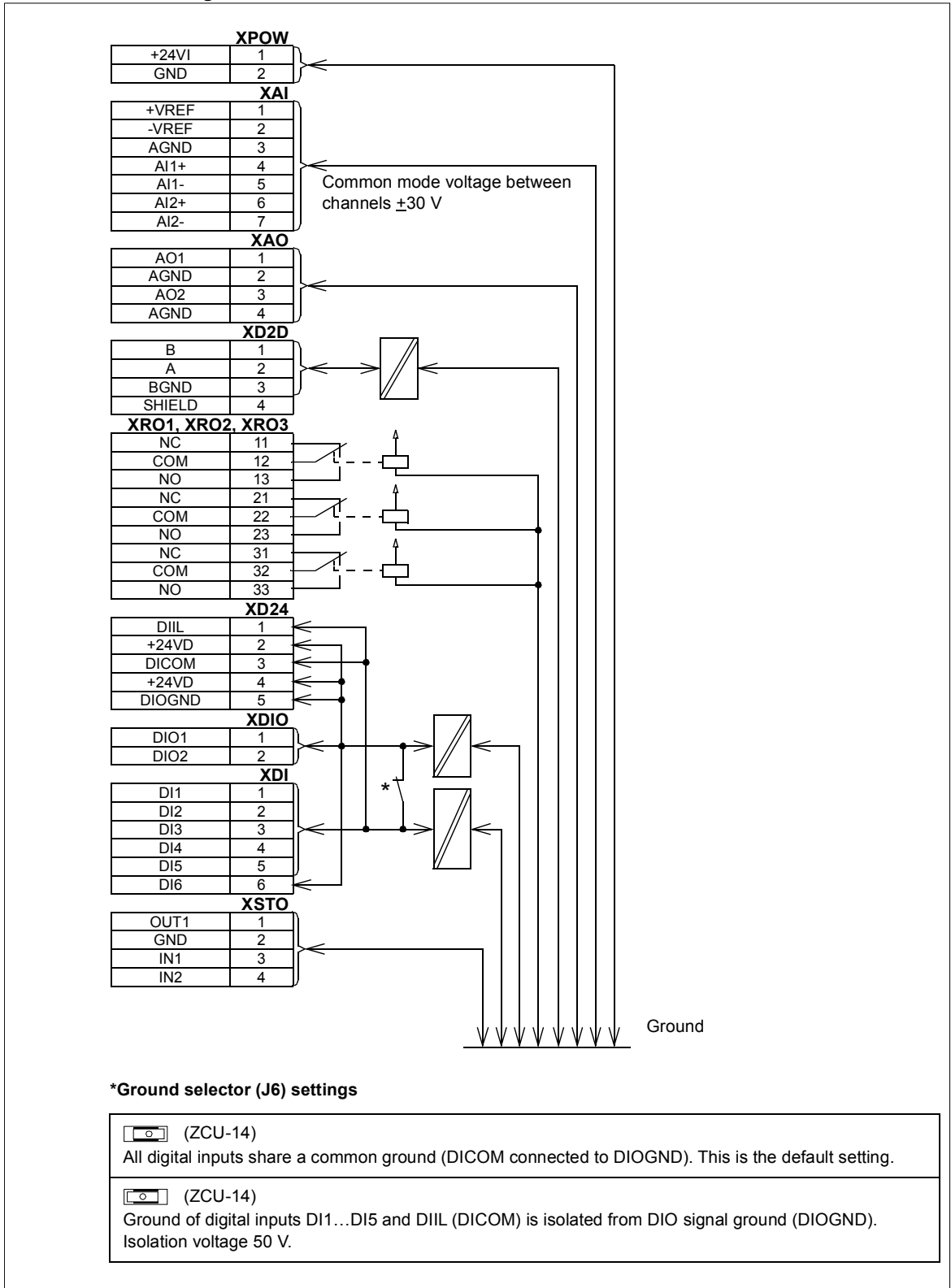





## 9

# Installation checklist

---

## Contents of this chapter

This chapter contains an installation checklist which you must complete before you start up the drive.

## Warnings



**WARNING!** Obey the instructions in chapter [Safety instructions](#). If you ignore them, injury or death, or damage to the equipment can occur.

## Checklist

Do the steps in section [Electrical safety precautions](#) (page 19) before you start the work. Go through the checklist together with another person.

Check that ...	<input checked="" type="checkbox"/>
The ambient operating conditions meet the specifications given in chapter <a href="#">Technical data</a> .	<input type="checkbox"/>
The drive cabinet has been fixed to floor, and if necessary due to vibration etc, also from top to the wall or roof.	<input type="checkbox"/>
The cooling air will flow freely in and out of the drive cabinet.	<input type="checkbox"/>
<u>If the drive will be connected to an IT (ungrounded) or a corner grounded TN network:</u> The optional EMC filter (+E202) of the drive (if any) has been disconnected. See page 106.	<input type="checkbox"/>
<u>If the drive has been stored over one year:</u> The electrolytic DC capacitors in the DC link of the drive have been reformed. See <a href="#">Converter module capacitor reforming instructions</a> (3BFE64059629 [English]).	<input type="checkbox"/>

---

Check that ...	<input checked="" type="checkbox"/>
There is an adequately sized protective ground conductor between the drive and the switchboard, and the conductor has been connected to appropriate terminal. Proper grounding has also been measured according to the regulations.	<input type="checkbox"/>
There is an adequately sized protective ground conductor between the motor and the drive, and the conductor has been connected to appropriate terminal. Proper grounding has also been measured according to the regulations.	<input type="checkbox"/>
<u>Only for drives with option brake chopper (option +D150):</u> There is an adequately sized protective earth (ground) conductor between the user-installed brake resistor and the drive, and the conductor has been connected to appropriate terminal. Proper grounding has also been measured according to the regulations.	<input type="checkbox"/>
The supply voltage matches the nominal input voltage of the drive. Check the type designation label.	<input type="checkbox"/>
The voltage setting of the auxiliary voltage transformers. See page 107.	<input type="checkbox"/>
The input power cable has been connected to the appropriate terminals, the phase order is correct, and the terminals have been tightened. (Pull on the conductors to check.)	<input type="checkbox"/>
The motor cable has been connected to the appropriate terminals, the phase order is right, and the terminals have been tightened. (Pull the conductors to check.)	<input type="checkbox"/>
The motor cable has been routed away from other cables.	<input type="checkbox"/>
No power factor compensation capacitors have been connected to the motor cable.	<input type="checkbox"/>
<u>If a drive bypass connection will be used:</u> The direct-on-line contactor of the motor and the drive output contactor are either mechanically or electrically interlocked, ie, cannot be closed simultaneously.	<input type="checkbox"/>
The external brake resistor (if present) has been connected to the appropriate terminals, and the terminals have been tightened. (Pull on the conductors to check.)	<input type="checkbox"/>
The external brake resistor cable (if present) has been routed away from other cables.	<input type="checkbox"/>
The control cables have been connected to the appropriate terminals, and the terminals have been tightened. (Pull the conductors to check.)	<input type="checkbox"/>
There are no tools, foreign objects or dust from drilling inside the drive.	<input type="checkbox"/>
All shrouds and cover of the motor connection box are in place. Cabinet doors have been closed.	<input type="checkbox"/>
The motor and the driven equipment are ready for start.	<input type="checkbox"/>

# 10

## Start-up

---

### Contents of this chapter

This chapter contains the start-up procedure of the drive.

### Start-up procedure

The tasks which are needed in certain cases only are marked with underlining, and option codes are given in brackets. Default device designations (if any) are given in brackets after the name, for example “main switch-disconnector (Q1)”. The same device designations are typically also used in the circuit diagrams.

These instructions cannot and do not cover all possible start-up tasks of a customized drive. Always refer to the delivery-specific circuit diagrams when proceeding with the start-up.



**WARNING!** Only qualified electrical professionals are allowed to do the work described in this chapter.

**Note:** For certain options (such as functional safety options +Q950, +Q951, +Q952, +Q957, +Q963, +Q964, +Q978, +Q979), additional start-up instructions are given in their separate manuals. See the listing of manuals inside the front cover.

---



<b>Action</b>	<input checked="" type="checkbox"/>
<b>Safety</b>	
 <b>WARNING!</b> Obey the safety instructions during the start-up procedure. See chapter <a href="#">Safety instructions</a> on page 15.	<input type="checkbox"/>
<b>Checks/Settings with no voltage connected</b>	
Ensure that the disconnecter of the supply transformer is locked to the off (0) position, ie. no voltage is, and cannot be connected to the drive inadvertently.	<input type="checkbox"/>
Check that the switch fuse (frame R8) (Q1) or main switch-disconnector (frame R11) (Q1) is switched off.	<input type="checkbox"/>
Check the mechanical and electrical installation of the drive. See <a href="#">Installation checklist</a> (page 161).	<input type="checkbox"/>
Check the settings of breakers/switches in the auxiliary circuits. See the circuit diagrams delivered with the drive.	<input type="checkbox"/>
Check the tap settings of transformers T21 (standard) and T101, T102 and T121.11 (if present). See page 107.	<input type="checkbox"/>
Disconnect any unfinished or uninspected auxiliary voltage (115/230 V AC) cables that lead from the terminal blocks to the outside of the equipment.	<input type="checkbox"/>
Check that both channels of the Safe torque off circuit connected to the STO inputs of drive control unit are closed. Refer to the wiring diagrams delivered with the drive.	<input type="checkbox"/>
If the Safe torque off functionality is used, check that the STO OUT output on the drive control unit is chained to the STO inputs of all drives. If the Safe torque off functionality is not used, check that the STO input on all drives is correctly wired to +24 V and ground.	<input type="checkbox"/>
For drives with ground fault monitoring for IT (ungrounded) systems (option +Q954): Adjust the settings of the ground fault monitor to suit the installation. See the circuit diagrams of the delivery and <i>IRDH275B Ground Fault Monitor Operating Manual</i> by Bender (code: TGH1386en).	<input type="checkbox"/>
For drives with Pt100 relays (option +(n)L506): <ul style="list-style-type: none"> <li>• Check the connections against the circuit diagrams of the delivery.</li> <li>• Set the alarm and trip levels of the Pt100 relays.</li> </ul> Set the alarm and trip levels of the Pt100 relay as low as possible based on the operating temperature and test results of the machine. The trip level can be set, for example, 10 °C higher than what the temperature of the machine is at maximal load in the maximum environmental temperature. We recommend to set the operating temperatures of the relay, typically for example, as follows: <ul style="list-style-type: none"> <li>• 120...140 °C when only tripping is in use</li> <li>• alarm 120...140 °C and trip 130...150 °C when both alarm and tripping are used.</li> </ul>	<input type="checkbox"/>
<b>Powering up the auxiliary circuit of the drive</b>	
Make sure that it is safe to connect voltage. Ensure that <ul style="list-style-type: none"> <li>• nobody is working on the drive or circuits that have been wired from outside into the drive cabinet</li> <li>• the cover of the motor terminal box is in place.</li> </ul>	<input type="checkbox"/>
For drives with a voltmeter (option +G334): Make sure that the circuit breaker of the measuring circuit (F5) is closed.	<input type="checkbox"/>
Close the circuit breakers and/or fuse disconnectors supplying the auxiliary voltage circuits.	<input type="checkbox"/>
Close the cabinet doors.	<input type="checkbox"/>
Close the main breaker of the supply transformer.	<input type="checkbox"/>



<b>Action</b>	<input checked="" type="checkbox"/>
Close the switch fuse (frame R8) (Q1) or main switch-disconnector (frame R11) (Q1). This will power up the main circuit of the drive as well as the auxiliary voltage circuit. <b>Note:</b> Do not use excessive force. The switch fuse (frame R8) or main switch-disconnector (frame R11) can only be closed when the main input terminals (L1, L2, L3) are powered.	<input type="checkbox"/>
<b>Setting up the line-side converter parameters</b>	
The line-side converter control program parameters are set at the factory. Normally, there is no need to change them at the start-up. For more information on the line-side converter control parameters, see <i>ACS880 primary control program firmware manual (3AUA0000085967 [English])</i> or <i>ACS880 IGBT supply control program firmware manual (3AUA0000131562 [English])</i> .	<input type="checkbox"/>
<b>Setting up the motor-side converter parameters, and performing the first start</b>	
Set up the motor control program. See the appropriate start-up guide and/or firmware manual. There is a separate start-up guide only for some control programs. If you need more information on the use of the control panel, see <i>ACX-AP-X Assistant control panels user's manual (3AUA0000085685 [English])</i> .	<input type="checkbox"/>
<u>For drives with a sine output filter (option +E206):</u> Check that parameter 95.15, bit 1 has been activated.	<input type="checkbox"/>
<u>For drives with a fieldbus adapter module (optional):</u> Set the fieldbus parameters. Activate the appropriate assistant (if present) in the control program, or see the user's manual of the fieldbus adapter module, and the drive firmware manual. Check that the communication works between the drive and the PLC.	<input type="checkbox"/>
<u>For drives with an encoder interface module (optional):</u> Set the encoder parameters. Activate the appropriate assistant (if present) in the control program, or see the user's manual of the encoder interface module, and the drive firmware manual.	<input type="checkbox"/>
<b>Activating the Run enable signal of the line-side converter (with options +Q951, +Q952 and +Q978)</b>	
Turn the operating switch (S21) to the ON (1) position to activate the run enable signal for the line-side converter.	<input type="checkbox"/>
<b>On-load checks</b>	
Start the motor to perform the ID run.	<input type="checkbox"/>
Check that the cooling fans rotate freely in the right direction, and the air flows upwards. A paper sheet set on the intake (door) gratings stays. The fans run noiselessly.	<input type="checkbox"/>
Check that the motor starts, stops and follows the speed reference in the correct direction when controlled with the control panel.	<input type="checkbox"/>
Check that the motor starts, stops and follows the speed reference in the correct direction when controlled through the customer-specific I/O or fieldbus.	<input type="checkbox"/>
<u>Drives in which the Safe torque off control circuit is connected in use:</u> Test and validate the operation of the Safe torque off function. See <i>Start-up including acceptance test</i> (page 271).	<input type="checkbox"/>
<u>Drives with functional safety options +Q950, +Q951, +Q952, +Q957, +Q963, +Q964, +Q978, +Q979:</u> Refer to the respective manuals of the safety option for option-specific start-up instructions.	<input type="checkbox"/>





11

# Fault tracing

---

## Contents of this chapter

This chapter describes the fault tracing possibilities of the drive.

### LEDs

Where	LED	Color	Indication
Control panel mounting platform	POWER	Green	Control unit is powered and +15 V is supplied to the control panel.
	FAULT	Red	Drive in fault state.

### Warning and fault messages

See the firmware manual for the descriptions, causes and remedies of the drive control program warning and fault messages.

---

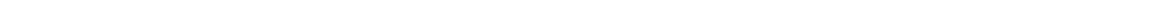



12

# Maintenance

---

## Contents of this chapter

This chapter contains preventive maintenance instructions.

## Maintenance intervals

The table below shows the maintenance tasks which can be done by the end user. The complete maintenance schedule is available on the Internet ([www.abb.com/drivesservices](http://www.abb.com/drivesservices)). For more information, consult your local ABB Service representative ( [www.abb.com/searchchannels](http://www.abb.com/searchchannels)).

Maintenance and component replacement intervals are based on the assumption that the equipment is operated within the specified ratings and ambient conditions. ABB recommends annual drive inspections to ensure the highest reliability and optimum performance.

**Note:** Long-term operation near the specified maximum ratings or ambient conditions may require shorter maintenance intervals for certain components. Consult your local ABB Service representative for additional maintenance recommendations.

---

**■ Descriptions of symbols**

Action	Description
I	Visual inspection and maintenance action if needed
P	Performance of on/off-site work (commissioning, tests, measurements or other work)
R	Replacement

**■ Recommended annual maintenance actions by the user**

Action	Target
I	IP22 and IP42 air inlet and outlet meshes on the cabinet doors
R	IP54 air filters on the cabinet doors
P	Quality of supply voltage
I	Spare parts
P	DC circuit capacitor reforming, spare modules and spare capacitors
I	Tightness of terminals
I	Dustiness, corrosion or temperature
I	Heat sink cleaning
I	ABB-SACE air circuit breaker maintenance

**■ Recommended maintenance intervals after start-up**

Component	Years from start-up						
	3	6	9	12	15	18	21
<b>Cooling</b>							
<b>Main cooling fan</b>							
Main cooling fan (R8) speed-controlled			R			R	
Main cooling fan (R11) speed-controlled			R			R	
Main cooling fan (R11 LCL) speed-controlled			R			R	
<b>Auxiliary cooling fan</b>							
Circuit board compartment cooling fans			R			R	
<b>Cabinet cooling fan</b>							
Internal cooling fan (R8 50 Hz)			R			R	
Internal cooling fan (R8 60 Hz)		R		R		R	
Cabinet cooling fan, door (50 Hz)			R			R	
Cabinet cooling fan, door (60 Hz)			R			R	
Cabinet cooling fan IP54 (50 Hz)			R			R	
Cabinet cooling fan IP54 (60 Hz)		R		R		R	
<b>NSIN filter cooling fan</b>							
NSIN filter cooling fan			R			R	
<b>Aging</b>							
ZCU control unit battery (real-time clock)		R		R		R	
Control panel battery (real-time clock)			R			R	

4FPS10000239703

## Cabinet

### ■ Cleaning the interior of the cabinet



**WARNING!** Obey the instructions in chapter [Safety instructions](#). If you ignore them, injury or death, or damage to the equipment can occur.



**WARNING!** Use a vacuum cleaner with an antistatic hose and nozzle, and wear a grounding wristband. Otherwise an electrostatic charge might build up and damage the circuit boards.

1. Stop the drive and do the steps in section [Electrical safety precautions](#) (page 19) before you start the work.
2. Open the cabinet doors.
3. Clean the interior of the cabinet. Use a vacuum cleaner and a soft brush.
4. Clean the air inlets of the fans and air outlets of the module (top).
5. Clean the air inlet gratings on the doors (see section [Cleaning the door air inlets \(IP22 and IP42\)](#) on page 171).
6. Close the doors.

### ■ Cleaning the door air inlets (IP22 and IP42)

1. Stop the drive and do the steps in section [Electrical safety precautions](#) (page 19) before you start the work.
2. Remove the fasteners at the top of the grating.
3. Lift the grating and pull it away from the door.
4. Vacuum clean or wash the grating on both sides.
5. Reinstall the grating in reverse order.

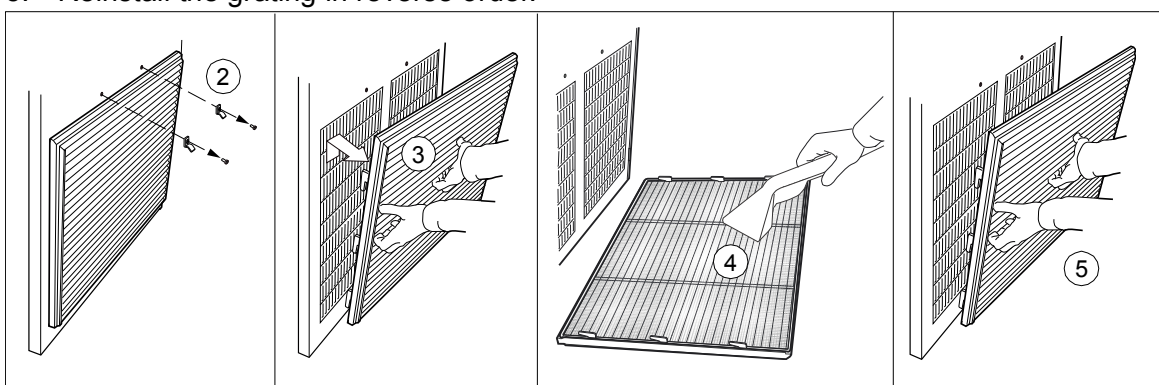

### ■ Cleaning the door air inlets (IP54)

1. Stop the drive and do the steps in section [Electrical safety precautions](#) (page 19) before you start the work.
2. Remove the fasteners at the top of the grating.
3. Lift the grating and pull it away from the door.
4. Remove the air filter mat.
5. Place the new filter mat in the grating the metal wire side facing the door.
6. Reinstall the grating in reverse order.

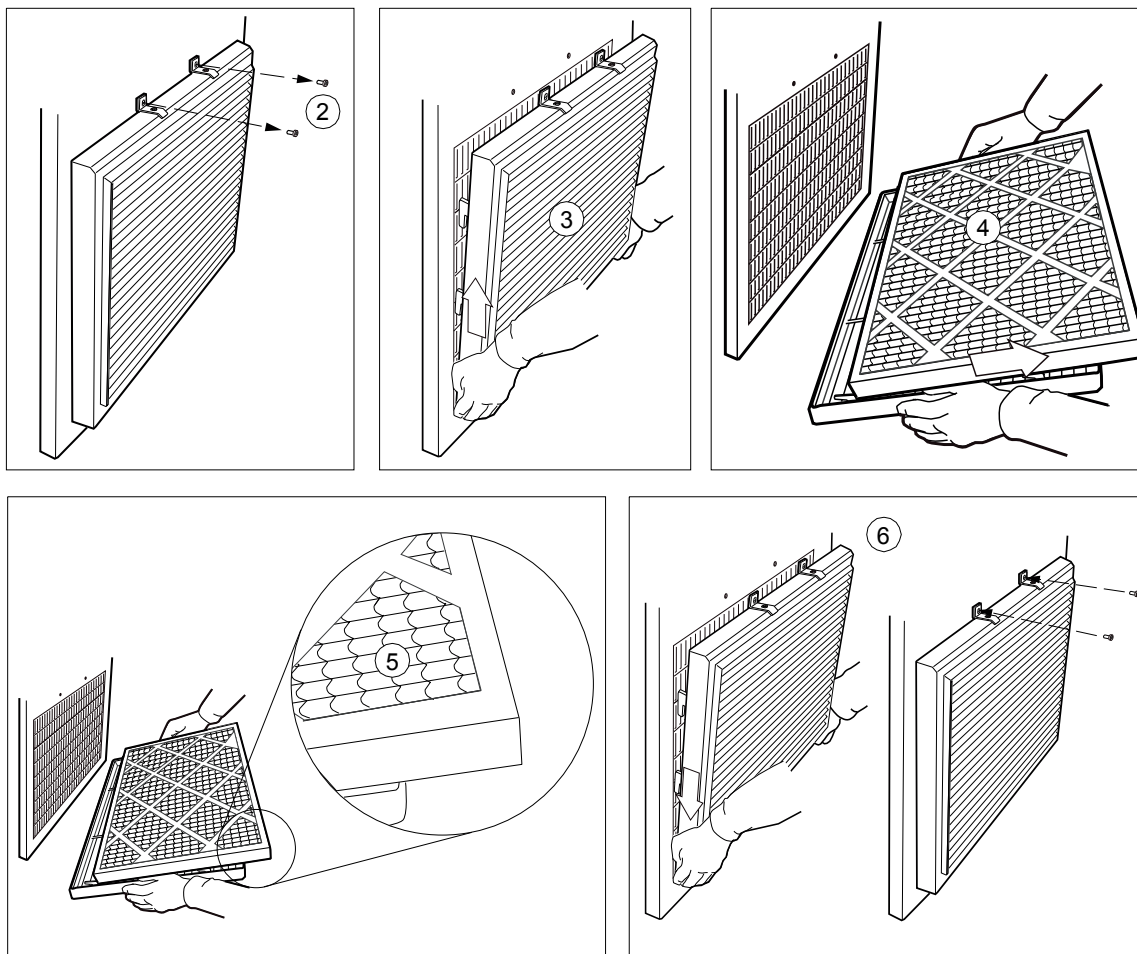

### ■ Cleaning the outlet (roof) filters (IP54)

The outlet (roof) filters in IP54 drives can be accessed by pulling the gratings upwards.

### ■ Replacing the outlet (roof) filters (IP54)

1. Stop the drive and do the steps in section [Electrical safety precautions](#) (page 19) before you start the work.
2. Remove the front and back gratings of the fan by lifting them upwards.
3. Remove the air filter mat.
4. Place the new filter mat in the grating.
5. Reinstall the grating in reverse order.

## Heatsink

The drive module heatsink fins pick up dust from the cooling air. The drive runs into overtemperature warnings and faults if the heatsink is not clean. When necessary, clean the heatsink as follows.



**WARNING!** Obey the instructions in chapter [Safety instructions](#). If you ignore them, injury or death, or damage to the equipment can occur.

---



**WARNING!** Use a vacuum cleaner with antistatic hose and nozzle. Using a normal vacuum cleaner creates static discharges which can damage circuit boards.

---

1. Stop the drive and do the steps in section [Electrical safety precautions](#) (page 19) before you start the work.
2. Remove the drive module from the cabinet. See section [Replacing the drive module \(frame R8\)](#) (page 188) and [Replacing the drive and LCL filter modules \(frame R11\)](#) (page 197).
3. Remove the module cooling fans. See section [Fans](#) below.
4. Blow dry clean compressed air (not humid) from bottom to top and simultaneously use a vacuum cleaner at the air outlet to trap the dust. **Note:** If there is a risk of dust entering adjoining equipment, perform the cleaning in another room.
5. Reinstall the cooling fans.

## Power connections

### ■ Retightening the power connections



**WARNING!** Obey the instructions in chapter [Safety instructions](#). If you ignore them, injury or death, or damage to the equipment can occur.

---

1. Stop the drive (if running) and do the steps in section [Electrical safety precautions](#) (page 19) before you start the work.
  2. Check the tightness of the cable connections. Use the tightening torques given in chapter [Technical data](#).
-

## Fans

The lifespan of the cooling fans of the drive depends on the running time, ambient temperature and dust concentration. See the firmware manual for the actual signal which indicates the running time of the cooling fan. Reset the running time signal after a fan replacement.

Replacement fans are available from ABB. Do not use other than ABB specified spare parts.

### ■ Replacing the cabinet “door fan”



**WARNING!** Obey the instructions in chapter [Safety instructions](#). If you ignore them, injury or death, or damage to the equipment can occur.

1. Stop the drive and do the steps in section [Electrical safety precautions](#) on page 19 before you start the work.
2. Open the cabinet door.
3. If there is a mounting plate/s above the fan, loosen the four screws and pull out the plate. Unplug the connectors and remove the plate.  
If there is no mounting plate/s, but instead a shroud/s above the fan, undo the four screws and remove the shroud/s.  
For frame R11 with option +C121: Undo the screws and remove the marine supports. See [Replacing the drive and LCL filter modules \(frame R11\)](#) on page 197.
4. Loosen the four mounting screws of the fan mounting plate.
5. Lift the mounting plate upwards.
6. Unplug the fan supply wires.
7. Lift the fan mounting plate off.
8. Undo the four mounting screws of the fan and remove the fan from the mounting plate. The finger guard of the fan is attached by the same screws on its front side. Keep the finger guard for reuse.
9. Install the new fan in reverse order.

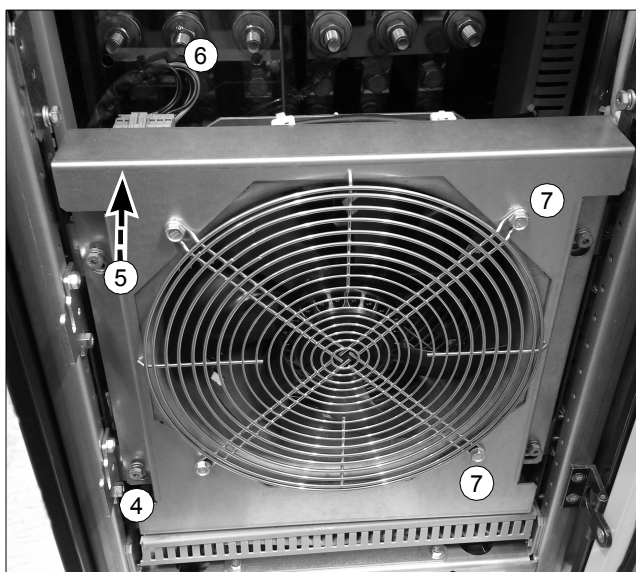
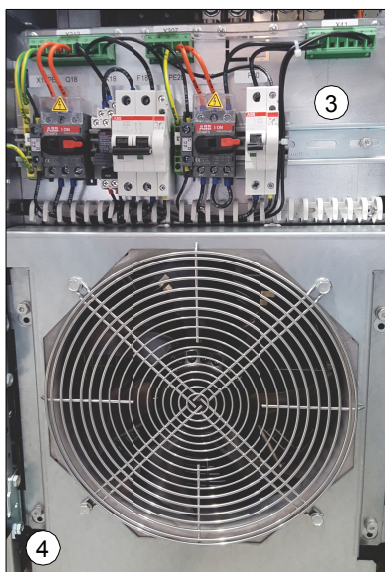

## ■ Replacing the internal cabinet cooling fans (frame R8)



**WARNING!** Obey the instructions in chapter [Safety instructions](#). If you ignore them, injury or death, or damage to the equipment can occur.

1. Stop the drive and do the steps in section [Electrical safety precautions](#) on page 19 before you start the work.
2. Open the cabinet door.
3. Remove the fuse replacement handle and shroud.
4. Remove the mounting plate.
5. Undo the four M6 combi screws and remove the air guide.
6. Unplug the fan plate connector.
7. Loosen the four combi screws, lift the fan up a bit and remove the fan plate.
8. Undo the four mounting screws of each fan (8 screws in total) and remove the fans from the mounting plate. The lower finger guards of the fans are attached with the same screws and removed at the same time.
9. Undo the four mounting screws of the top finger guards of the fans (8 screws in total). Keep all finger guards for reuse.
10. Install the new fans in reverse order to the above.

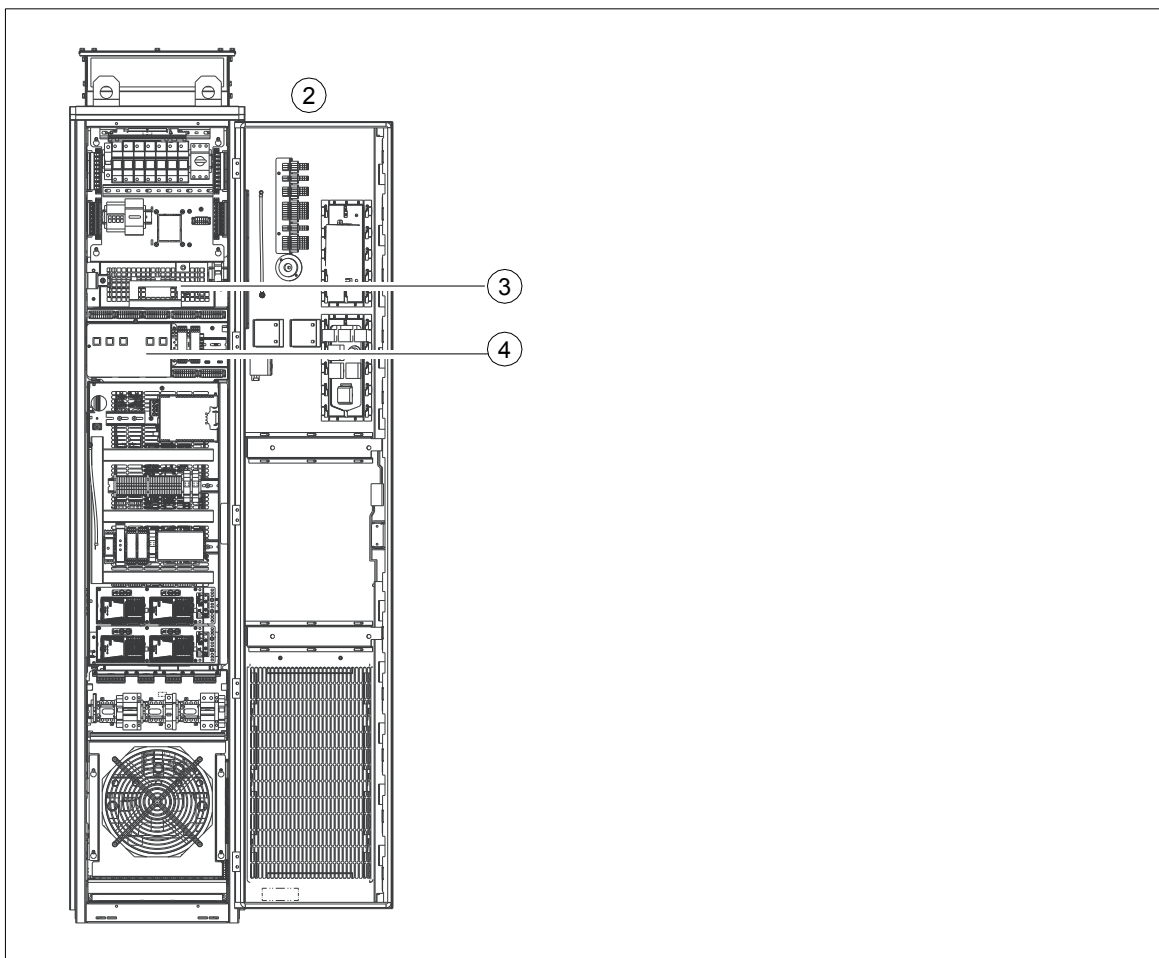

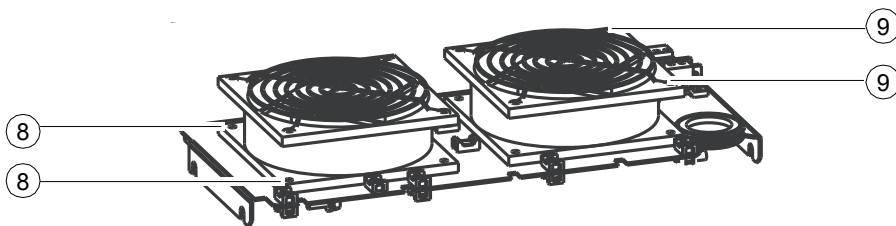
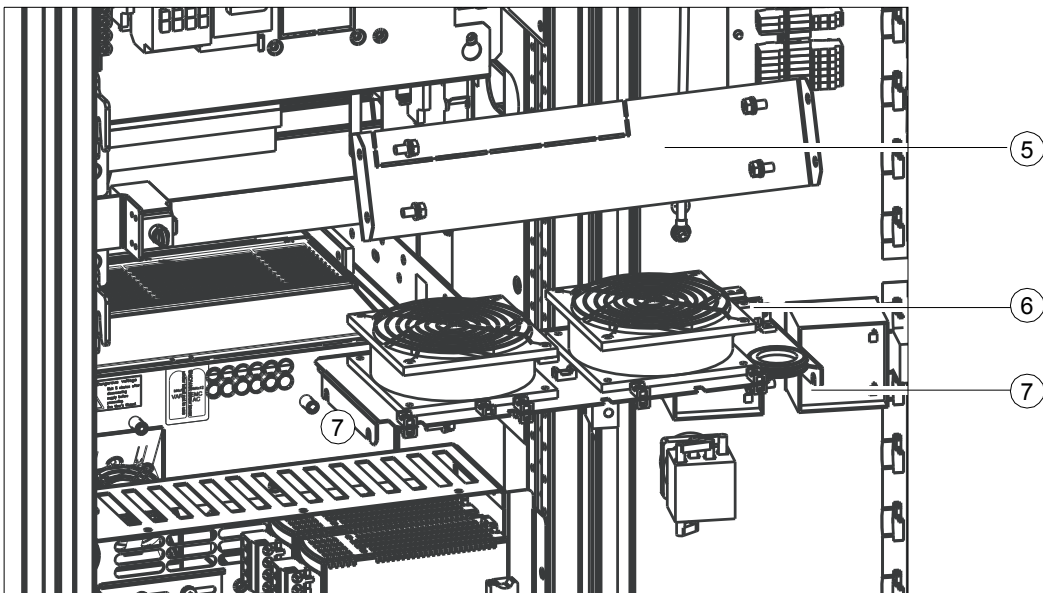
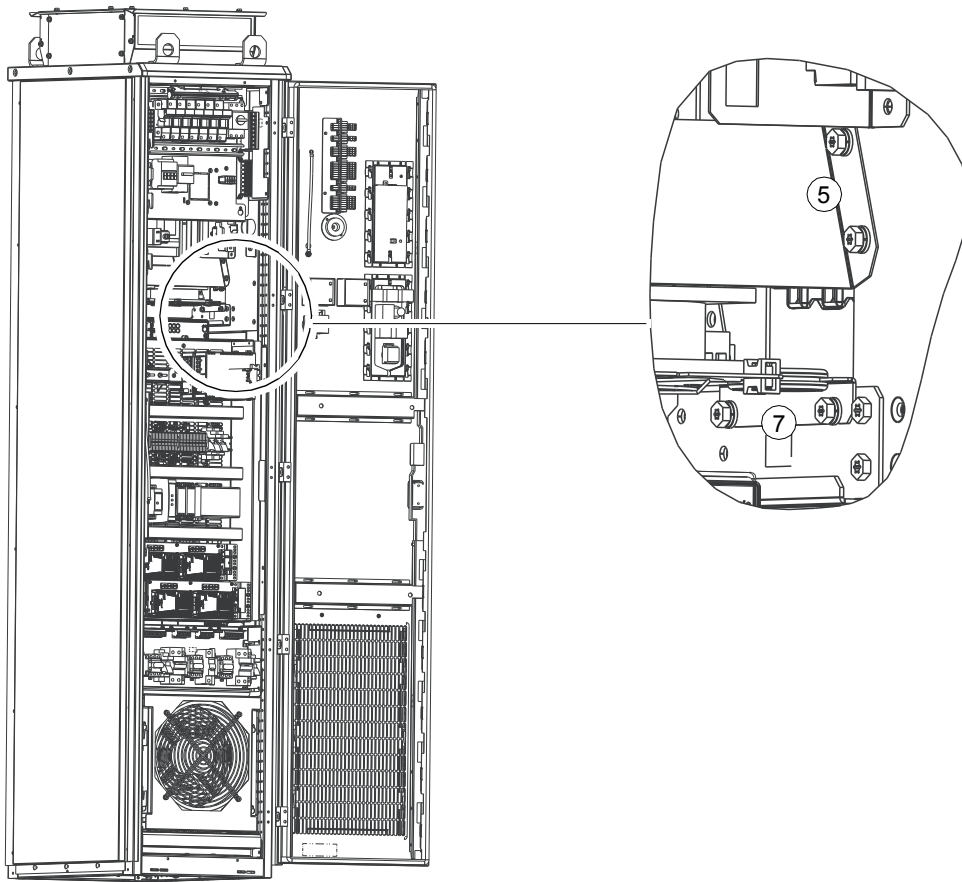



## ■ Replacing the drive module main fan (frame R8)



**WARNING!** Obey the instructions in chapter [Safety instructions](#). If you ignore them, injury or death, or damage to the equipment can occur.

1. Stop the drive and do the steps in section [Electrical safety precautions](#) on page 19 before you start the work.
2. Open the cabinet door.
3. Slide the drive module forward as described under [Replacing the drive module \(frame R8\)](#) on page 188.
4. Undo the mounting screws of the fan mounting plate (view from bottom below).
5. Pull the fan mounting plate down from the side edge.
6. Unplug the power supply wires.
7. Lift the fan mounting plate off.
8. Remove the fan from the mounting plate. The finger guard of the fan is attached by the same screws and is removed at the same time. Keep the finger guard for reuse.
9. Install the new fan in reverse order.
10. Close the cabinet door.
11. Reset the counter (if used) in group 5 in the primary control program.

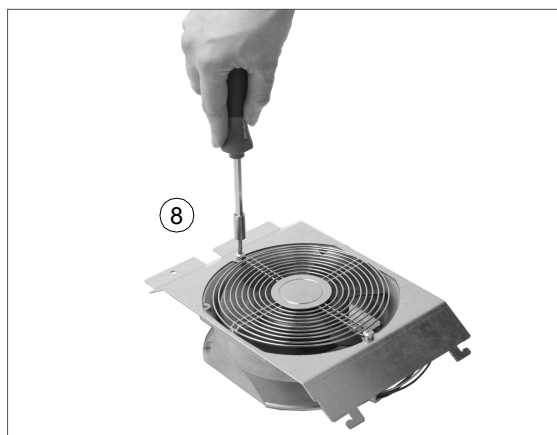
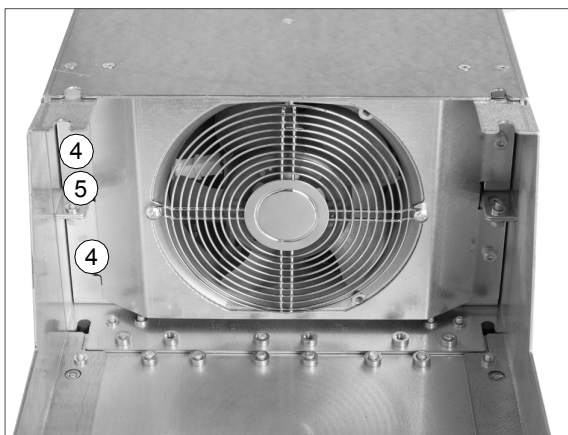

## ■ Replacing the drive module main fans (frame R11)



**WARNING!** Obey the safety instructions in chapter [Safety instructions](#). If you ignore them, injury or death, or damage to the equipment can occur.

---

1. Stop the drive and do the steps in section [Electrical safety precautions](#) on page 19 before you start the work.
  2. To remove the marine supports in drives with option +C121, see [Replacing the drive and LCL filter modules \(frame R11\)](#) on page 197.
  3. To open the module section swing-out frame, undo the M10 bolts from top and bottom (4 pcs). See [Replacing the drive and LCL filter modules \(frame R11\)](#) on page 197.
  4. Disconnect the power supply wires of the fans from the connectors FAN1:PWR1 and FAN2:PWR2.  
**Note:** 690 V R11 drive modules have only one fan in the cassette.
  5. Undo the mounting screws of the fan cassette.
  6. Pull the fan cassette out.
  7. Undo the mounting screws of the fan(s). The finger guard of the fan is attached by the same screws and is removed at the same time. Keep the finger guard for reuse.
  8. Install the new fans in reverse order to the above. For 690 V drive modules, connect the fan power supply wires to connector FAN1:PWR1. For the other drive modules, connect the power supply wires to both FAN1:PWR1 and FAN2:PWR2.
  9. Close the swing-out frame, reinstall the 4 screws and marine supports (option +C121) and close the cabinet doors.
  10. Reset the counter (if used) in group 5 in the primary control program.
-

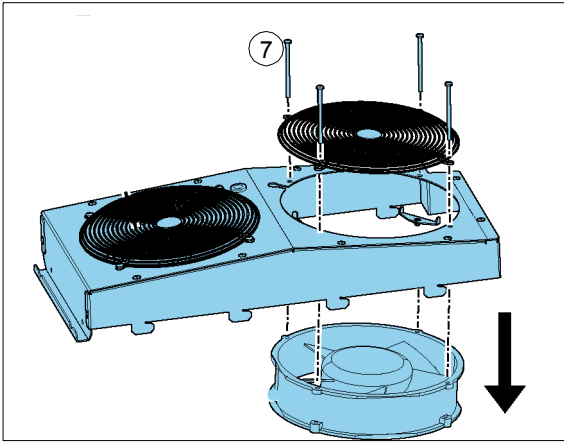
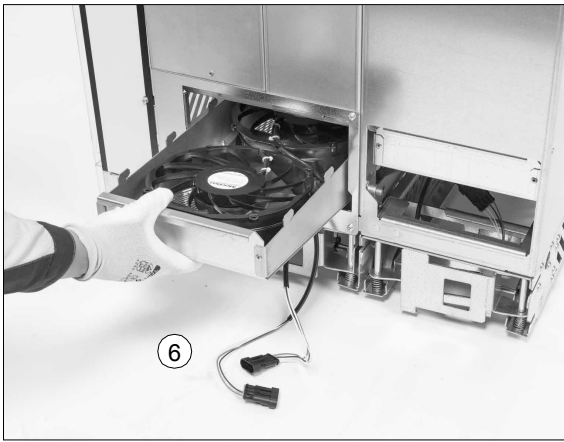
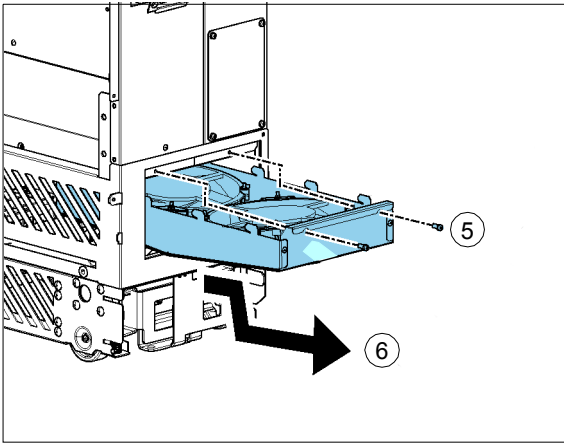
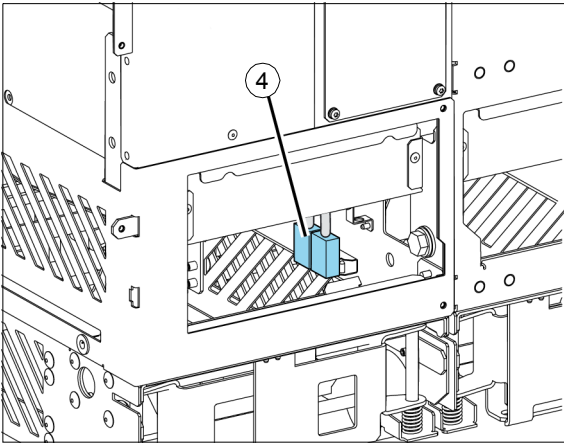

## ■ Replacing the LCL filter module fan (frame R11)



**WARNING!** Obey the safety instructions in chapter [Safety instructions](#). If you ignore them, injury or death, or damage to the equipment can occur.

1. Stop the drive and do the steps in section [Electrical safety precautions](#) on page 19 before you start the work.
2. To remove the marine supports in drives with option +C121, see [Replacing the drive and LCL filter modules \(frame R11\)](#) on page 197.
3. To open the module section swing-out frame, undo the M10 bolts from top and bottom (4 pcs). See [Replacing the drive and LCL filter modules \(frame R11\)](#) on page 197.
4. Disconnect the power supply wire of the fan from connector FAN3:LCL.
5. Undo the mounting screw of the fan cassette.
6. Pull the fan cassette out.
7. Undo the mounting screws of the fan. The finger guard of the fan is attached by the same screws and is removed at the same time. Keep the finger guard for reuse.
8. Install the new fan in reverse order to the above. Make sure that the arrow in the fan points up.
9. Close the swing-out frame, reinstall the 4 screws and marine supports (option +C121) and close the cabinet doors.

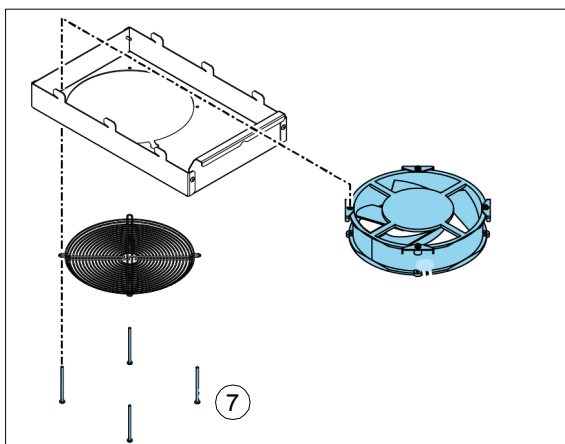
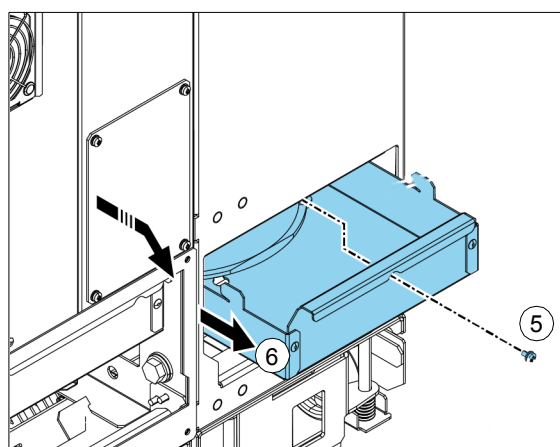
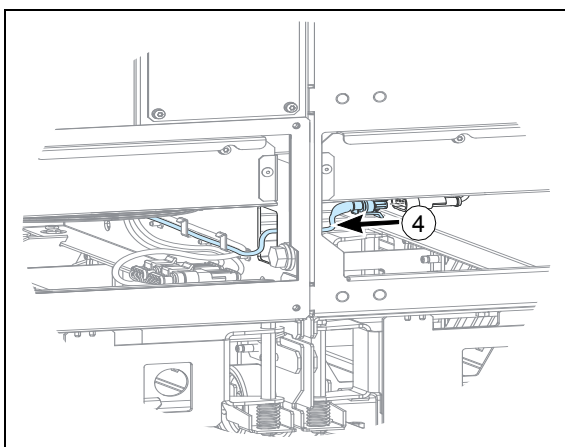

## ■ Replacing the auxiliary cooling fan of the drive module (frame R8)



**WARNING!** Obey the instructions in chapter [Safety instructions](#). If you ignore them, injury or death, or damage to the equipment can occur.

1. Stop the drive and do the steps in section [Electrical safety precautions](#) on page 19 before you start the work.
2. Open the cabinet door.
3. Open the swing-out frame or remove the shroud if there is no swing-out frame.
4. Unplug the power supply wires from the control unit terminal X208:FAN2.
5. Lift the fan up.
6. Install the new fan in reverse order. Make sure that the arrow on the fan points up.
7. Close the swing-out frame and cabinet door.
8. Reset the counter (if used) in group 5 in the primary control program.

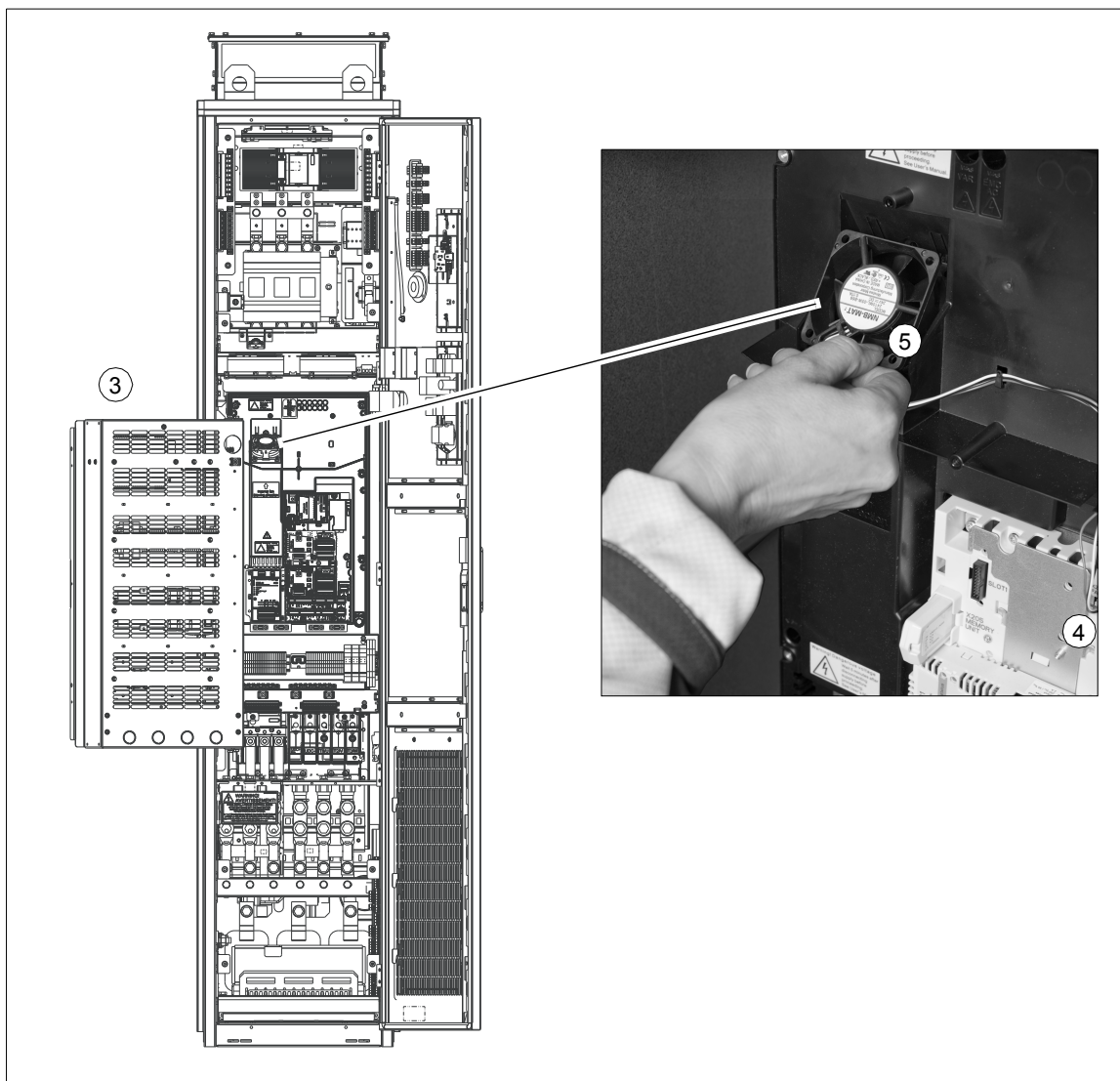

■ Replacing the auxiliary cooling fans of the drive module (frame R11)



**WARNING!** Obey the safety instructions in chapter *Safety instructions*. If you ignore them, injury or death, or damage to the equipment can occur.

Fan in the front panel:

1. Stop the drive and do the steps in section *Electrical safety precautions* on page 19 before you start the work.
2. Open the cabinet doors.
3. Undo the mounting screw of the fan cassette.
4. Unplug the power supply cable of the fan.
5. Undo the mounting screws of the fan.
6. Install the new fan in reverse order to the above. Make sure that the arrow in the fan points to the drive module.
7. Close the cabinet door.
8. Reset the counter in group 5 in the primary control program.

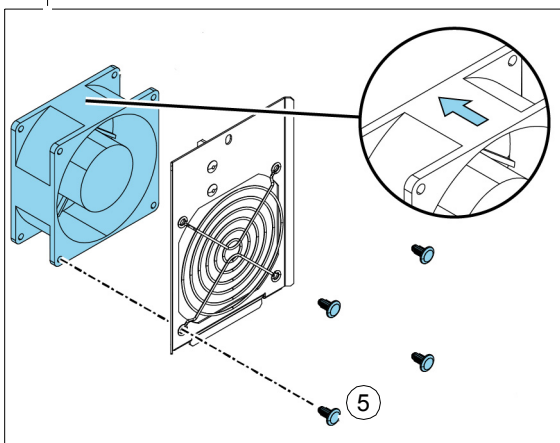
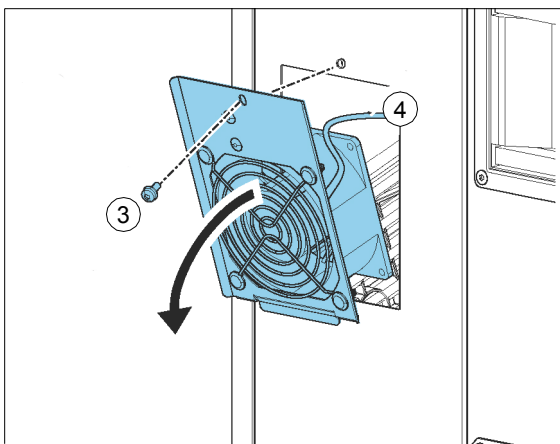
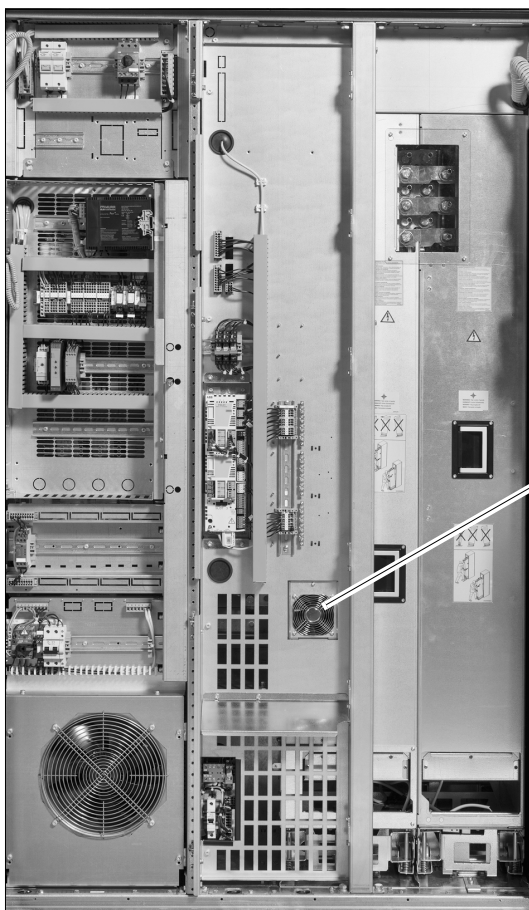

Fan at the bottom of the circuit board compartment:

1. Stop the drive and do the steps in section *Electrical safety precautions* on page 19 before you start the work.
2. Open the cabinet door.
3. To remove the marine supports in drives with option +C121, see *Replacing the drive and LCL filter modules (frame R11)* on page 197.
4. To open the swing-out frame, undo the M10 bolts from top and bottom (4 pcs). The fan locates in the bottom part of drive module circuit board compartment.

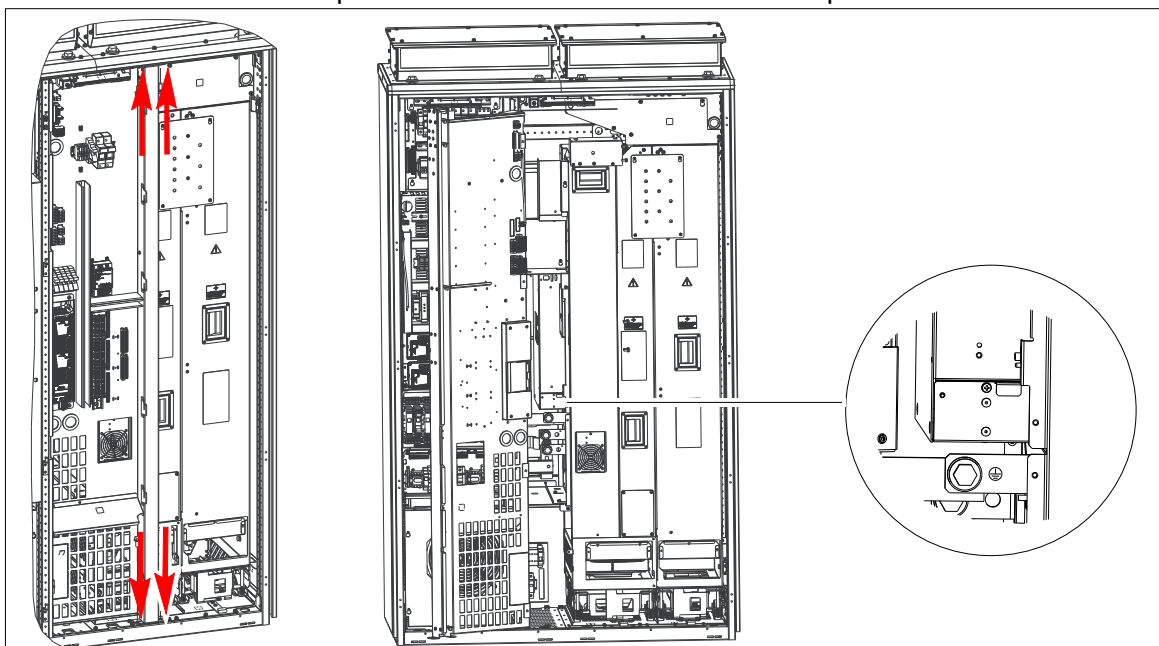

5. Undo the mounting screw of the fan cassette.
6. Pull the fan cassette out.
7. Unplug the power supply cable of the fan.
8. Undo the mounting screws of the fan.
9. Install the new fan in reverse order to the above. Make sure that the arrow in the fan points up.
10. Close the swing-out frame, reinstall the 4 screws and marine supports (option +C121) and close the cabinet doors.
11. Reset the counter (if used) in group 5 in the primary control program.

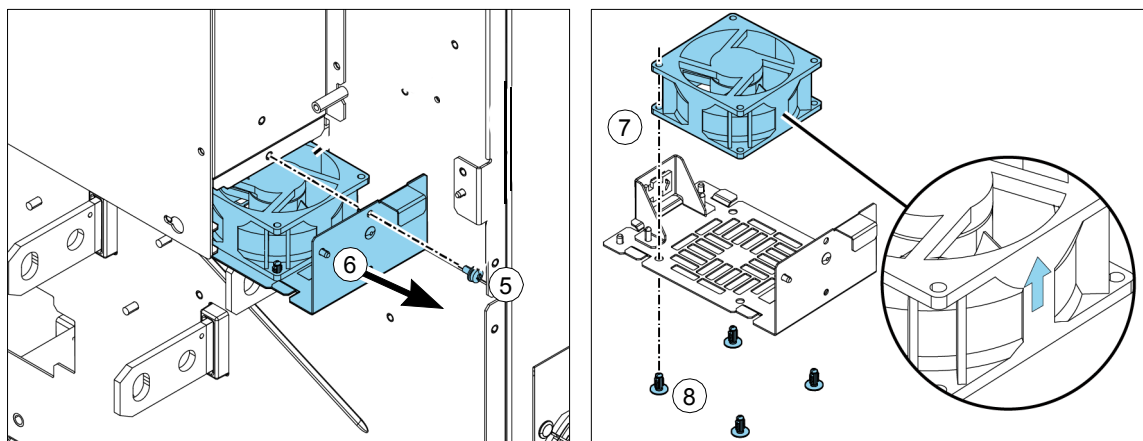

## ■ Frame R8: Replacing the IP54 (UL Type 12) roof fan and brake chopper (option +D150) cubicle fan G101.2



**WARNING!** Obey the instructions in chapter [Safety instructions](#). If you ignore them, injury or death, or damage to the equipment can occur.

1. Stop the drive and do the steps in section [Electrical safety precautions](#) on page 19 before you start the work.
2. Slide the front grating upwards and remove it.
3. Remove the air filter.
4. Loosen the mounting screws of the front mesh. Remove the mesh.
5. Disconnect the fan supply wires.
6. Undo the mounting screws of the fan.
7. Pull the fan out.
8. Install the new fan in reverse order.

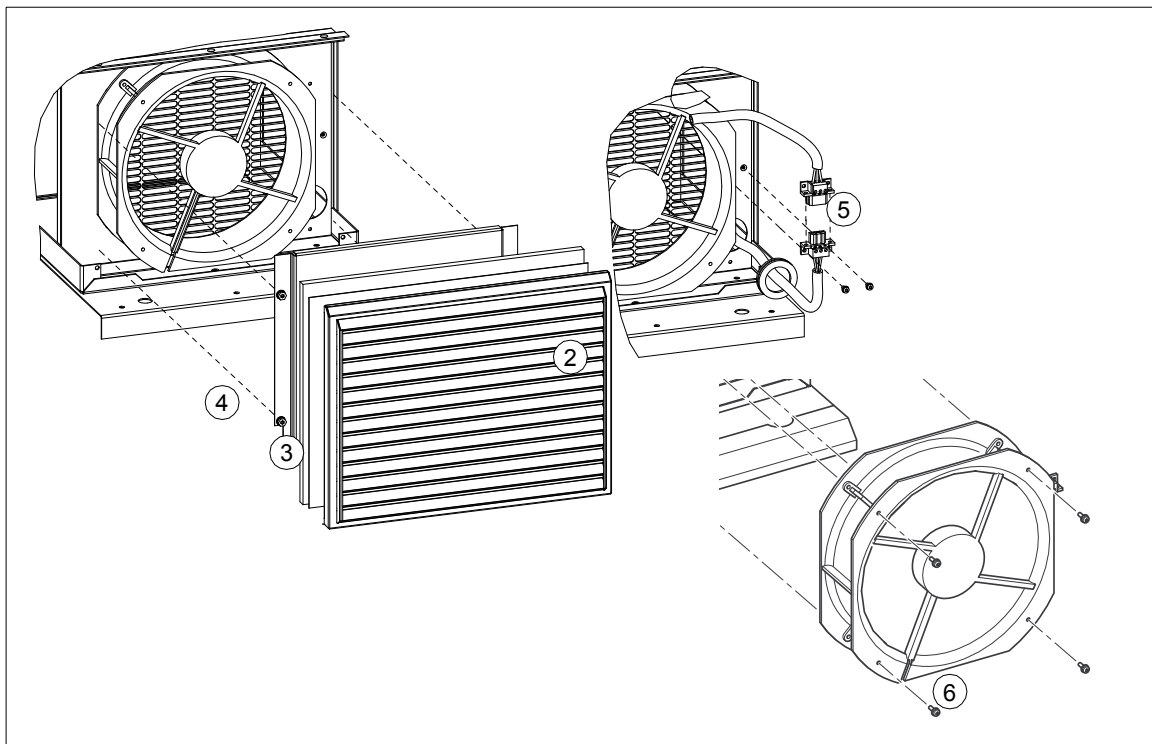



## ■ Frame R11 with options +B055 and +C128: Replacing the roof fan



**WARNING!** Obey the instructions in chapter [Safety instructions](#). If you ignore them, injury or death, or damage to the equipment can occur.

1. Stop the drive and do the steps in section [Electrical safety precautions](#) on page 19 before you start the work.
2. Slide the front gratings upwards and remove them.
3. Remove air filters.
4. To remove the wire mesh, undo the mounting screws.
5. Disconnect the fan power supply wires.
6. Remove the mounting screws of the fan.
7. Remove the fan.
8. Install the new fan in reverse order.

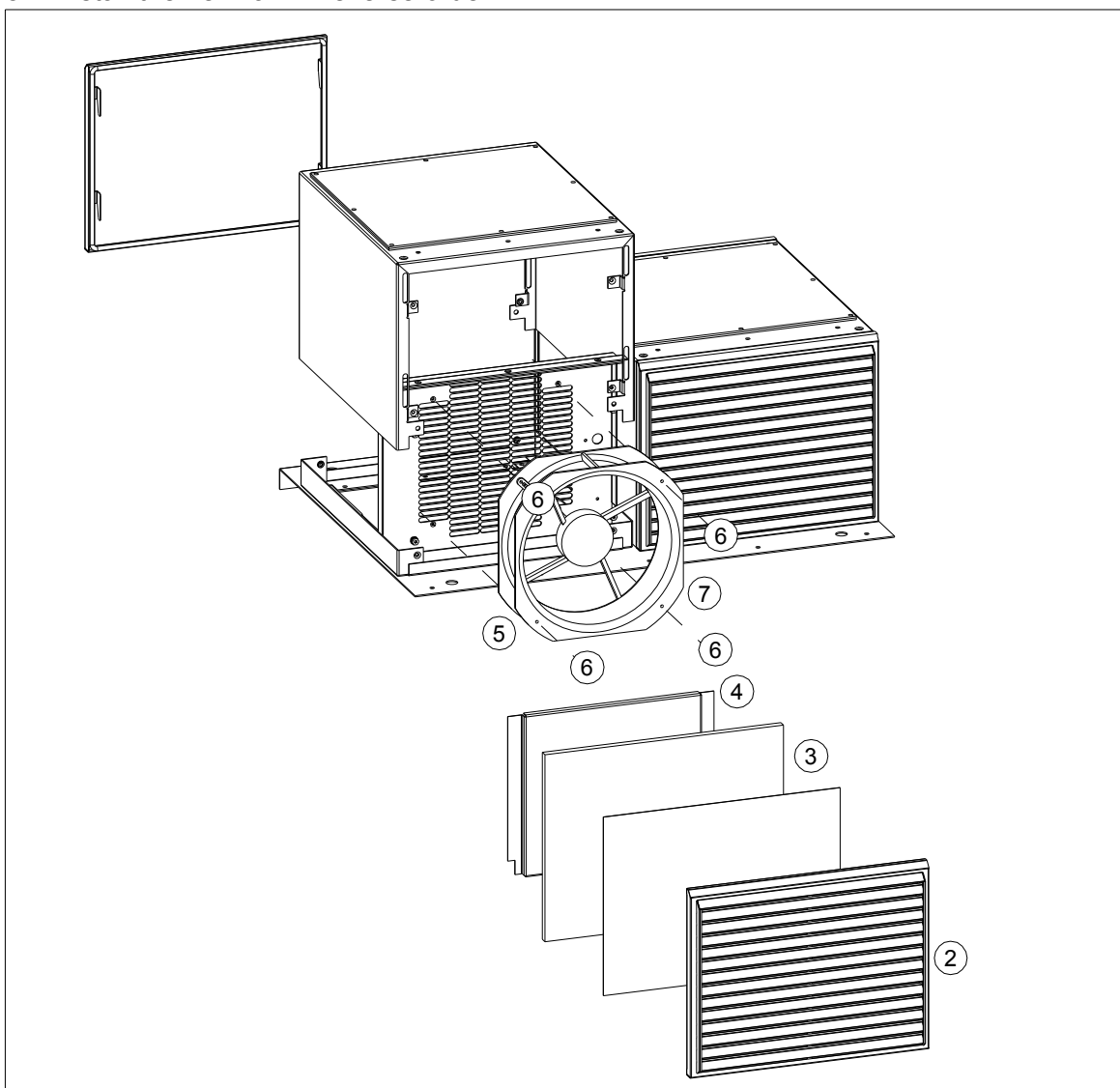

## ■ Frame R11 with option +B055: Replacing the roof fan



**WARNING!** Obey the instructions in chapter [Safety instructions](#). If you ignore them, injury or death, or damage to the equipment can occur.

1. Stop the drive and do the steps in section [Electrical safety precautions](#) on page 19 before you start the work.
2. Slide the front grating upwards and remove it.
3. Remove the air filter.
4. Undo the four M6 combi screws and remove the mesh.
5. Disconnect the fan power supply wires.
6. Undo the two M6 combi screws, lift the fan assembly upwards and slide it out.
7. Remove the mounting screws of the fan and replace the fan.

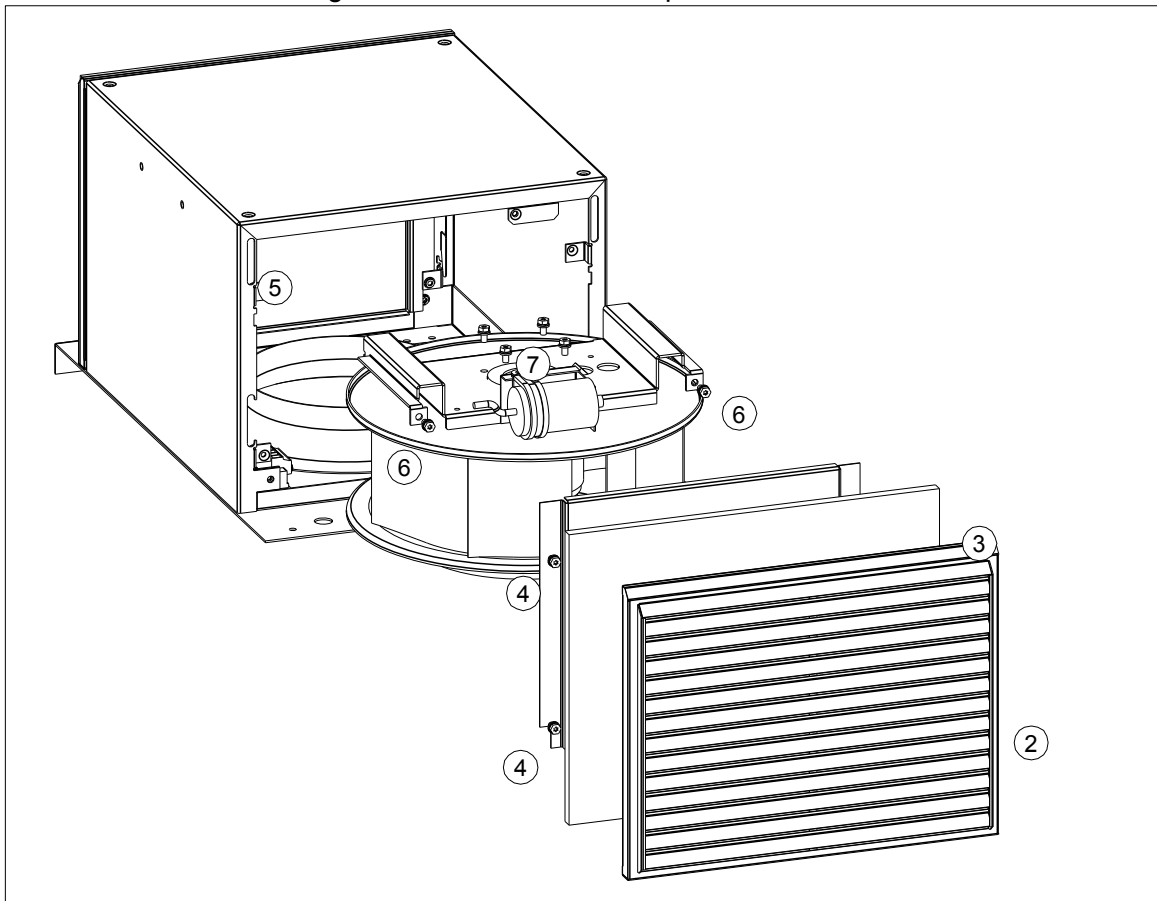

## ■ Replacing the brake chopper (option +D150) cubicle fan



**WARNING!** Obey the instructions in chapter [Safety instructions](#). If you ignore them, injury or death, or damage to the equipment can occur.

1. Stop the drive and do the steps in section [Electrical safety precautions](#) on page 19 before you start the work.
2. Open the cabinet door.
3. Unplug fan socket.
4. Unscrew fan mounting screws (4 pcs).
5. Slide the fan out.
6. Install the new fan in reverse order.

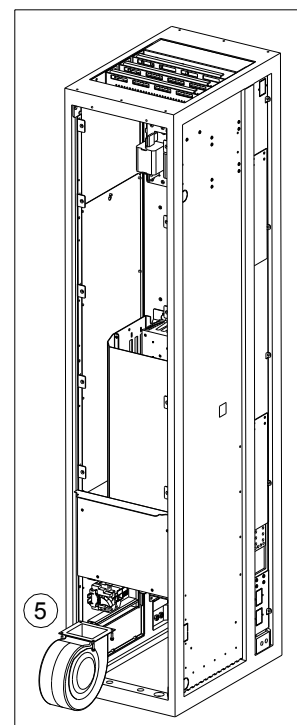
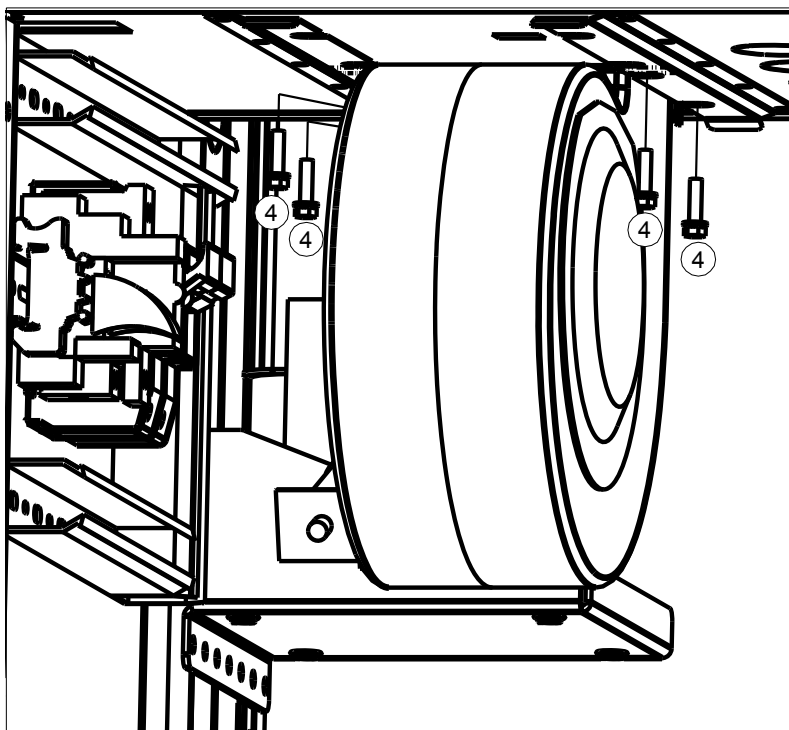

## ■ Replacing the sine filter cooling fan

For replacing the cooling fans of NSINxxx-x sine filters, see *Sine filters hardware manual* (3AXD50000016814 [English]).

## Replacing the drive module (frame R8)

### ■ Required tools

- lifting device
- set of screw drivers
- torque wrench with an extension bar
- lifting chains.

A lifting device is available from ABB with order code 3AXD50000047447.

### ■ Safety



**WARNING!** Obey the instructions in chapter [Safety instructions](#). If you ignore them, injury or death, or damage to the equipment can occur. Secure the cabinet to the floor to prevent it from toppling over when you slide out the heavy drive module.

---

1. Stop the drive (if running) and do the steps in section [Electrical safety precautions](#) (page [19](#)) before you start the work.
  2. Open the cabinet door.
  3. Remove the fuse replacement handle.
  4. Remove the shroud. For drives with option +C121: Remove the marine shroud.
  5. Unplug the connectors and remove the mounting plate.
-

6. For drives with option +C121: Undo the three M6 screws on the left side of the swing-out frame.

All drives: Undo the two M6 screws on the right side of the swing-out frame and open the swing-out frame or remove the shroud and four shroud fixing brackets if there is no swing-out frame.

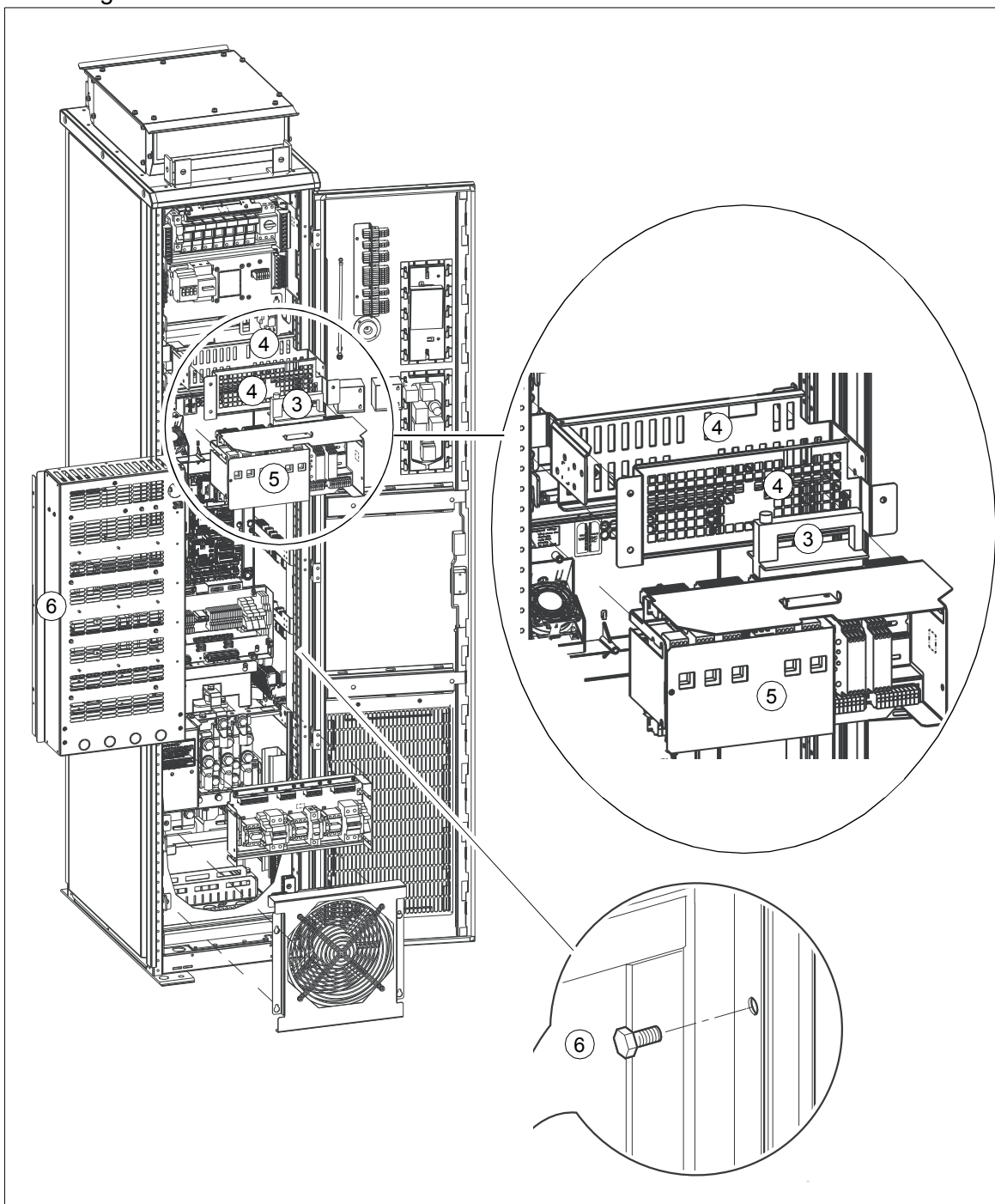

7. Disconnect the control panel cable from the module and the control wire terminals on the right side of the cabinet.
8. If the swing-out frame does not open enough to allow module replacement, undo the swing-out frame grounding wire and lift the swing-out frame off its hinges.
9. To remove the mounting plate above the “door fan”, loosen the mounting screws and lift the plate up or remove the shroud and four fixing brackets if there is no mounting plate.

For drives with options +G300, +G301, +G307 and +G313: Disconnect the control cable terminals at the back side of the mounting plate.

10. Unplug the connector and remove the fan or remove the shroud if there is no fan.

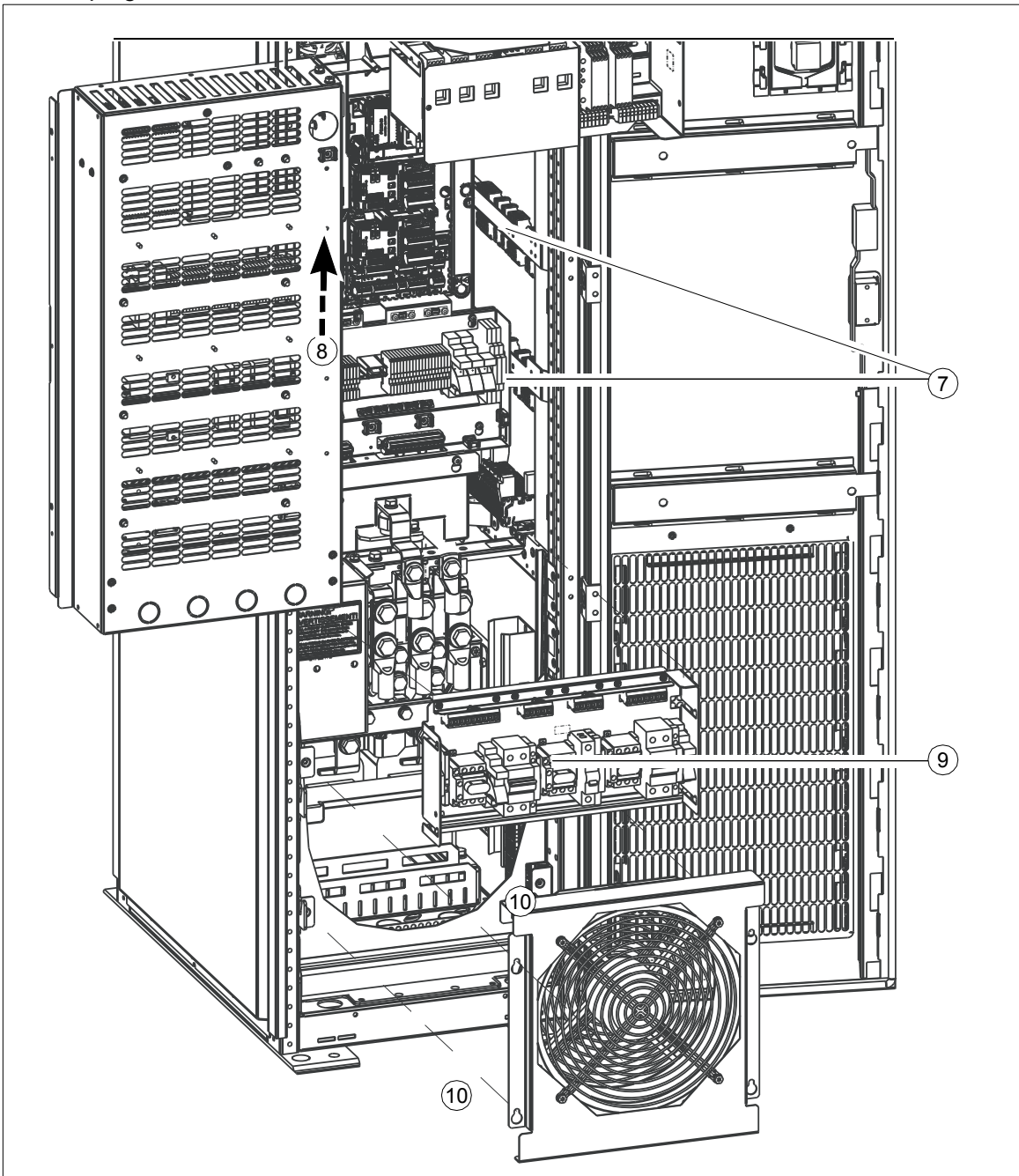

11. Loosen the four M5 screws and remove the plastic shroud.

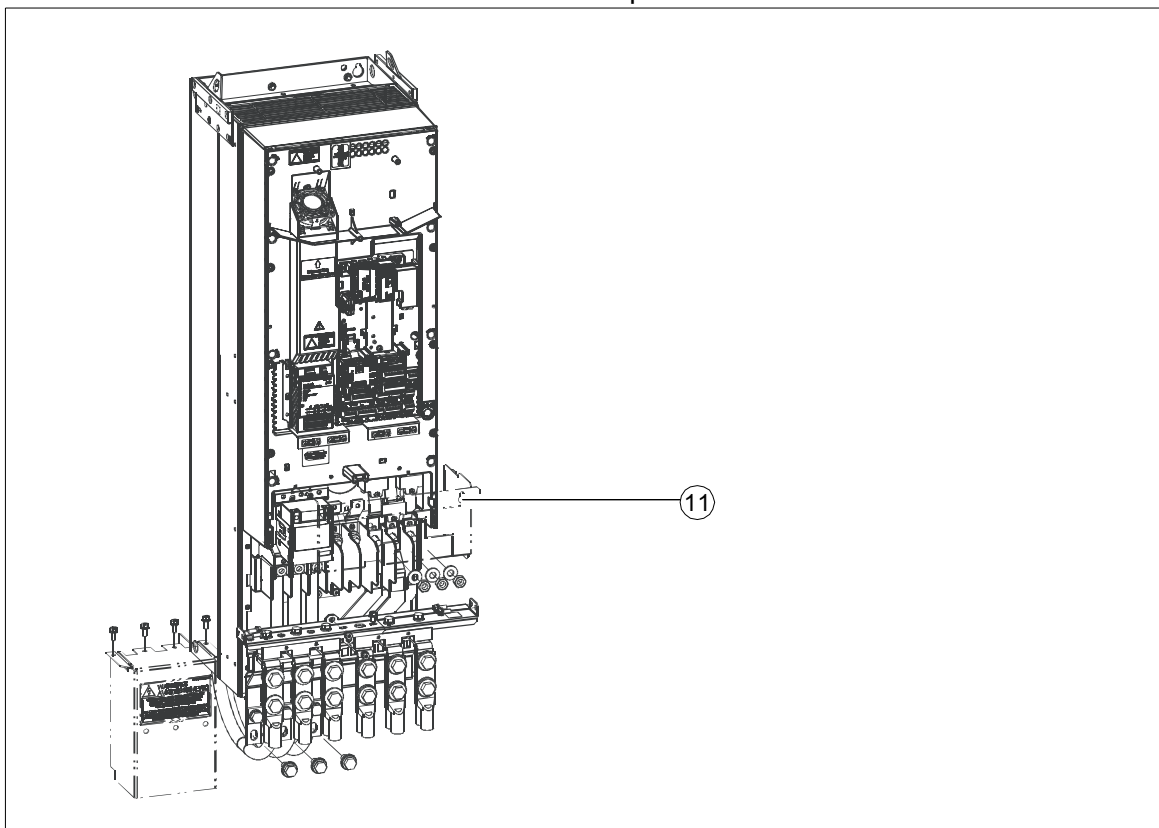

12. For drives with bottom entry: Undo the four M6 combi screws and remove the plastic shroud.
13. For drives with bottom entry or exit: Remove the connection terminal subassembly:  
Undo the screws or nuts:
- Bottom entry (a): three M10 screws
- Note:** If you find it difficult to access the screws of steps 13a or 13c, you can disconnect the power cables of step 14 and remove the terminal subassembly.
- Bottom exit from module (b): three M10 nuts
  - Bottom exit and common mode filter (option +E208) or du/dt filter (option +E205) (c): three M10 nuts
14. For drives with bottom entry or exit: Undo the 7 M6 screws and bend down the left half of the connection terminal subassembly. Then bend down the right half of the subassembly so that the power cables do not disturb the module replacement.
- Note:** If you find it difficult to access the screws of steps 13a or 13c, you can disconnect the power cables of step 14 and remove the terminal subassembly.
15. Top exit or bottom exit and option +E208 or E205: Undo the three M10 nuts. Bend the three motor cables down so that they do not disturb the module replacement.
16. Loosen the three hex head screws, pull out three power cables and bend them down so that they do not disturb the module replacement.
17. For drives with brake chopper (option +D150) : Undo the two M10 nuts and bend the two power cables down so that they do not disturb the module replacement.

Bottom exit from module

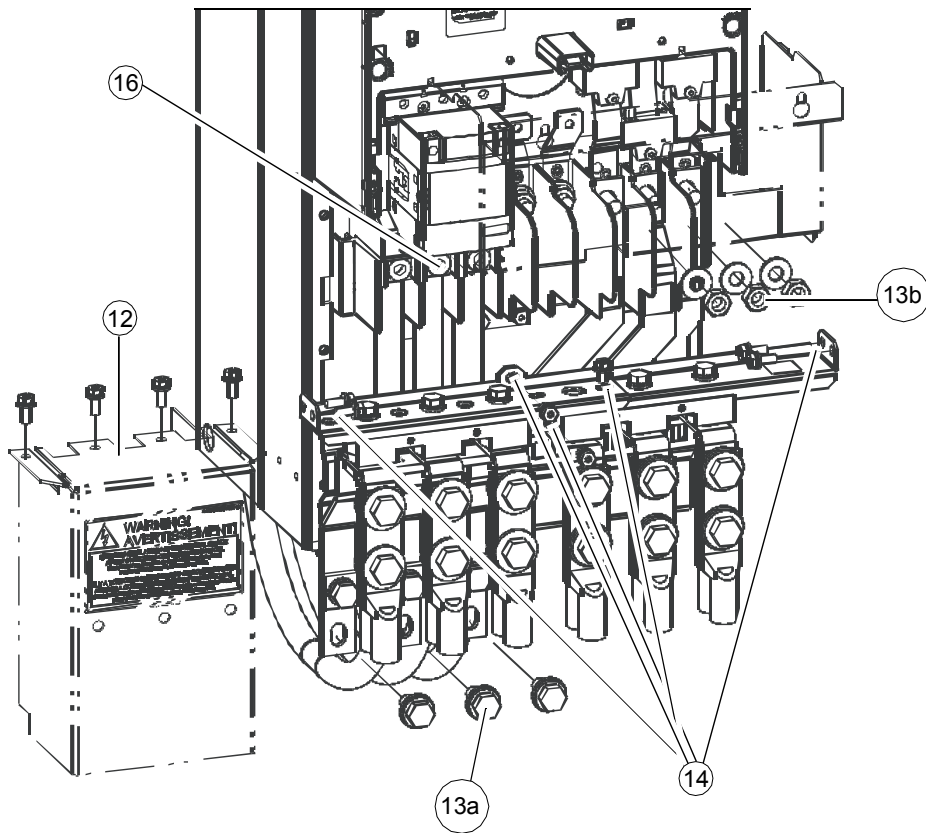

Bottom exit with +E208 or +E205

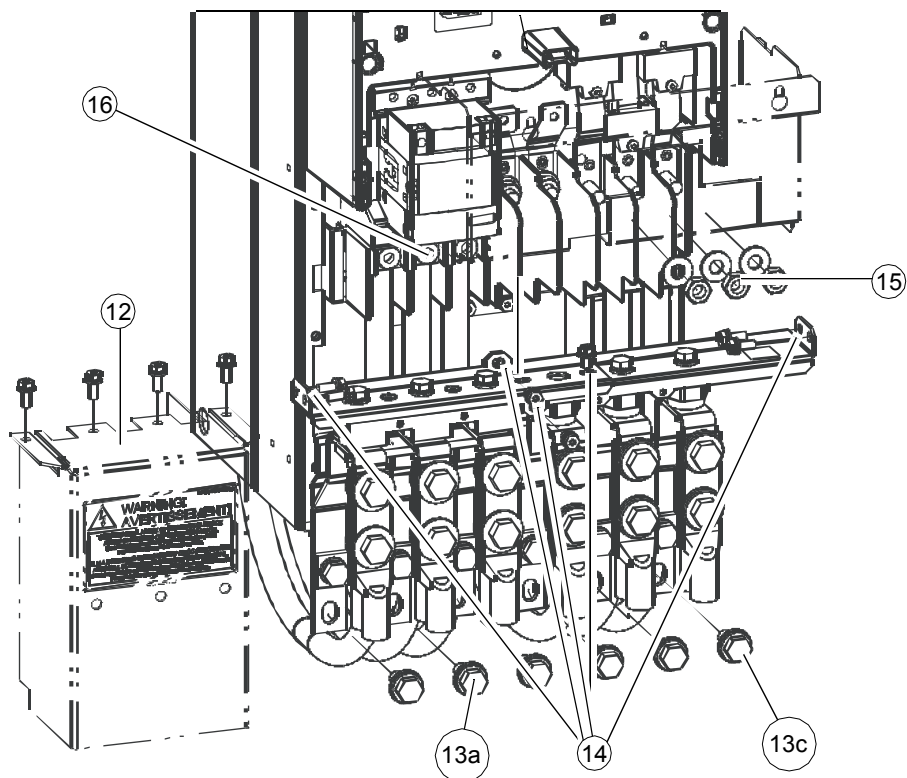



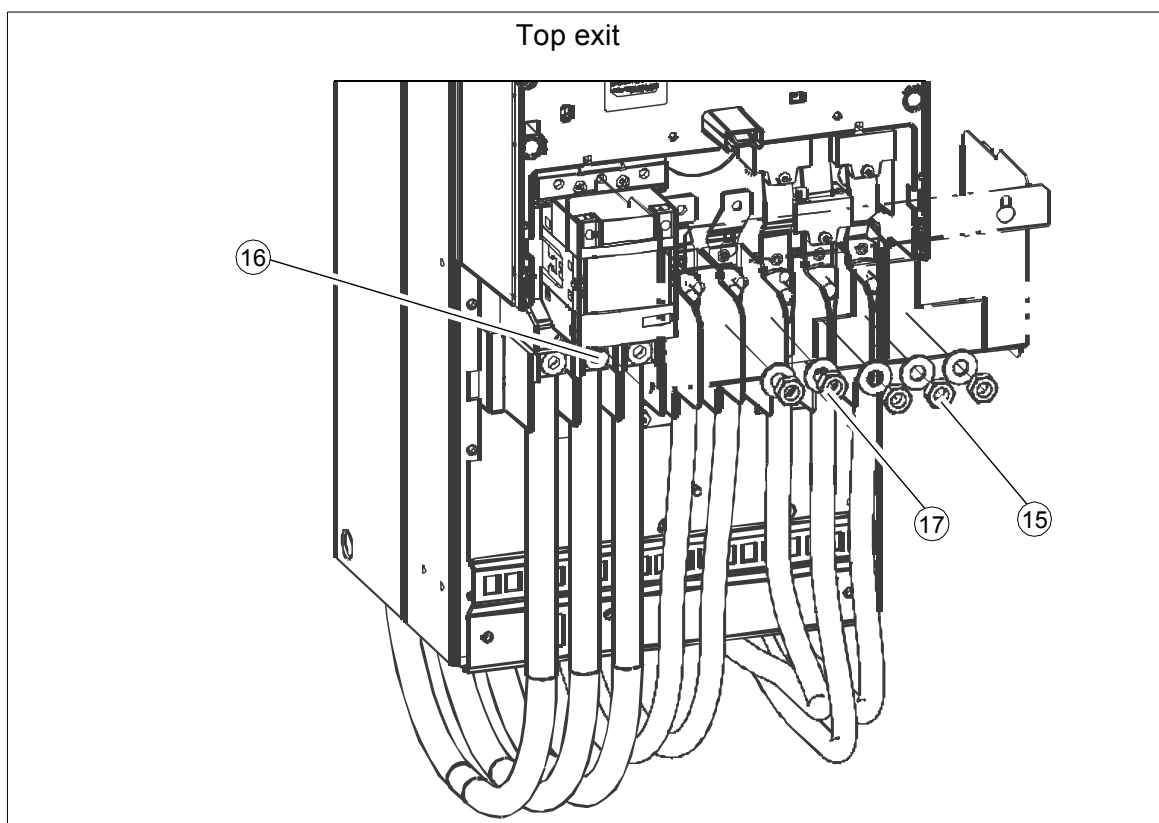

18. Undo the four M6 combi screws and remove the plastic air guide.
19. Loosen the four M6 combi screws, unplug the connector, lift the fan up a bit and remove the fan plate.
20. For easier removal of the module, undo the four M6 combi screws, disconnect the wires of the thermal switch and remove the plastic air guide.
21. For easier removal of the module, undo the four M6 combi screws and remove the plastic air guide.

22. Unplug the wires and connectors of X504 mounting plate.

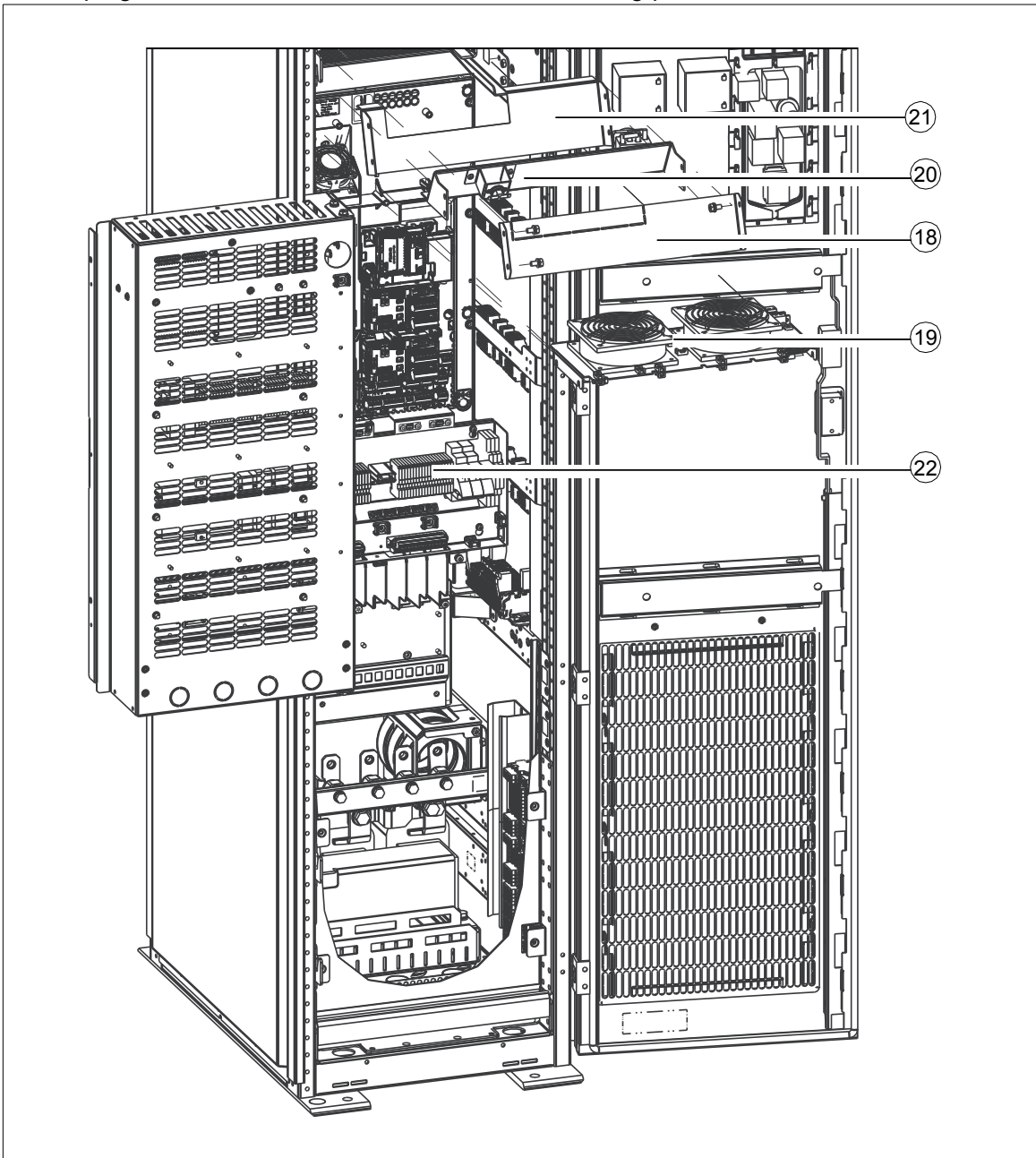

23. Undo the four M8 Serpress® nuts.

24. Undo the two M6 self-tapping screws in the bottom left side of the cabinet and remove the module slide extension rails.

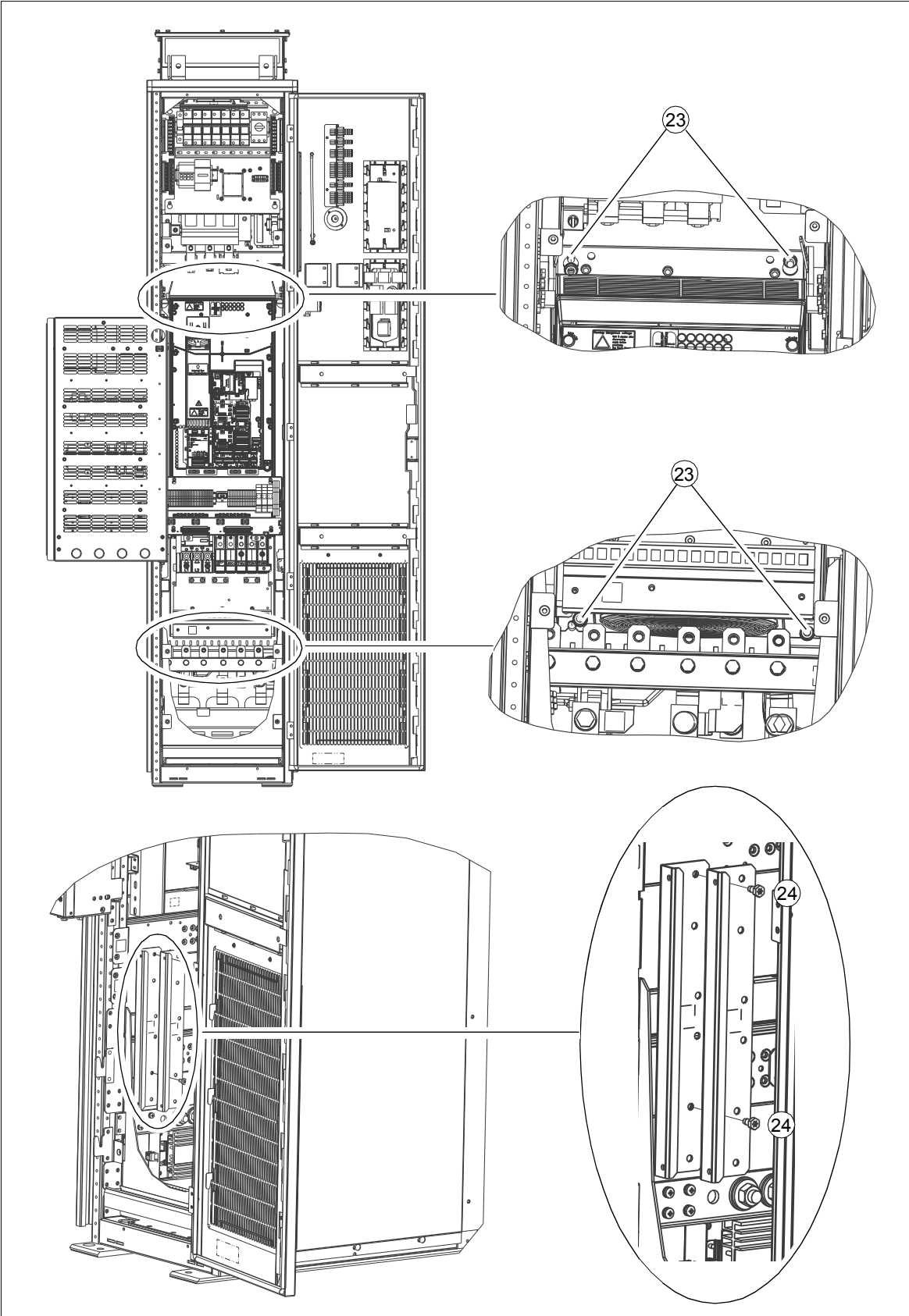

25. Install the extension rails at the end of the sliding bars.

26. Slide the drive module towards the end of the sliding bars.

27. Secure the drive module with chains from the lifting eyes.
28. Lift the module out of the cabinet with a lifting device.
29. Loosen the four M5 combi screws and remove X504 mounting plate.
30. Remove the four M4 standoffs and place them to a new module.
31. Place X504 mounting plate to the new module and attach the M5 combi screws.
32. Install the new module in reverse order.

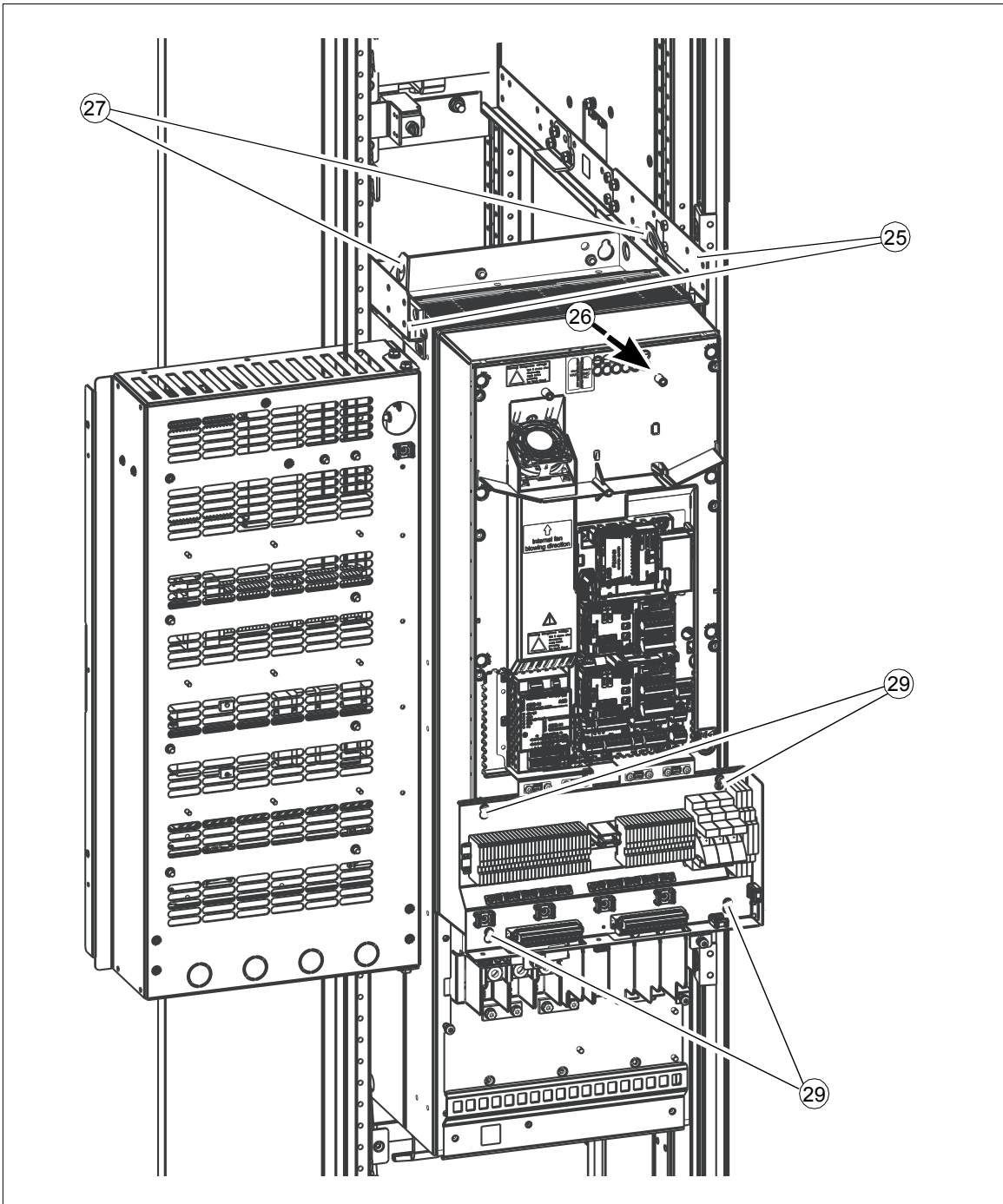

## Replacing the drive and LCL filter modules (frame R11)

### ■ Required tools

- installation ramp
- set of screw drivers
- torque wrench with an extension bar
- lifting chains.

### ■ Safety



**WARNING!** Obey the instructions in chapter [Safety instructions](#). If you ignore them, injury or death, or damage to the equipment can occur.

- Handle the drive and LCL filter modules carefully:
  - Use safety shoes with a metal toe cap to avoid foot injury.
  - Lift the module only by the lifting lugs.
  - Make sure that the module does not topple over when you move it on the floor: Extend the support legs: Press each leg a little down and turn it aside. Whenever possible secure the module also with chains.

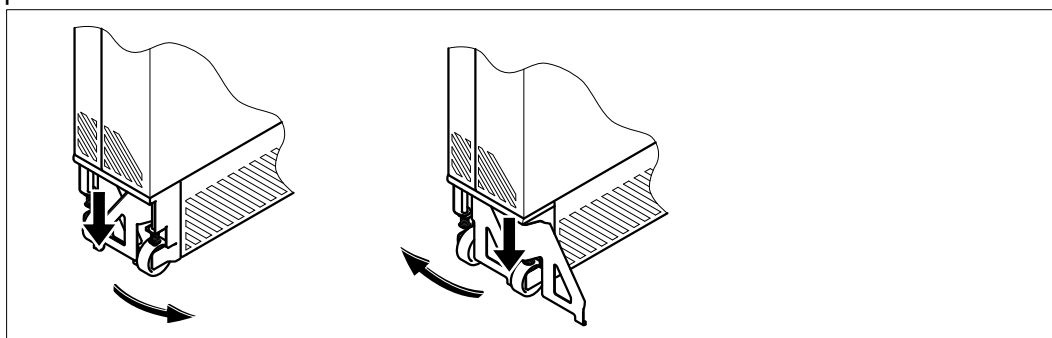

- Do not tilt the drive module. It is **heavy** and its **center of gravity is high**. Do not leave the module unattended on a sloping floor.

### ■ Replacing the drive module (frame R11)

Replacing the drive module requires preferably two persons.

1. Stop the drive (if running) and do the steps in section [Electrical safety precautions](#) (page 19) before you start the work.
2. Open the cabinet doors.
3. For drives with option +C121:  
 Undo the two module attaching screws (3a).  
 Undo the M6 screws and remove the three supports (3b).  
 Undo the five M6 screws on the left side of the swing-out frame (3c).

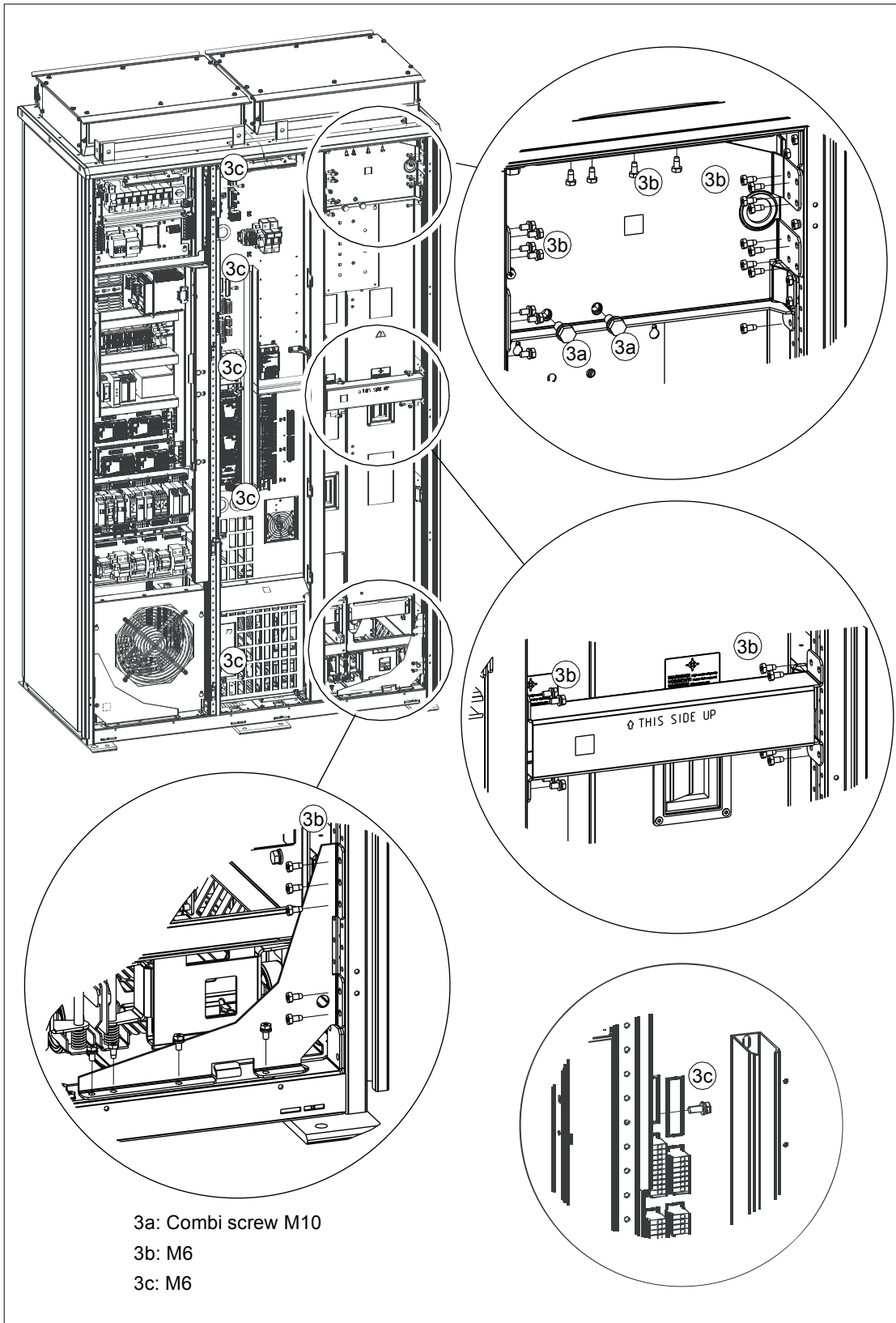

- 4. To open the module section swing-out frame, undo the M10 bolts from top and bottom (4 pcs).

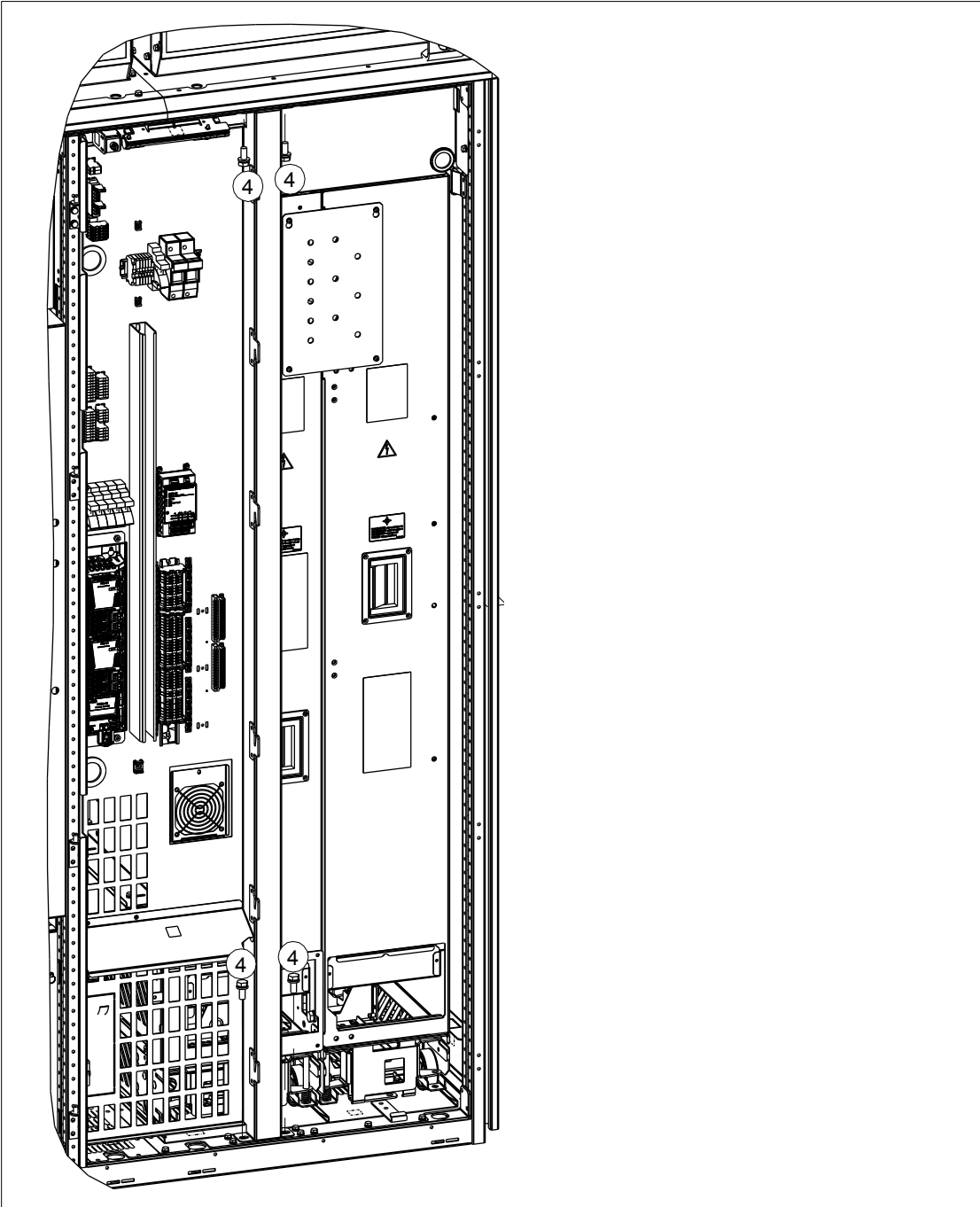

5. Loosen the two M6 screws of the air baffle and push it to the left. (Not for drives with option +C128.)
6. Remove the air baffle.
7. Remove the air baffle. (Not for drives with option +C121.)
8. Remove the air baffle: (8a) in IP22/IP42 drives, (8b) in IP54 drives.
9. Disconnect all cables from line-side converter control unit (from terminal X2, INU STO connector and the fiber optic cables from the V8, V13, V2 and V7 connectors).

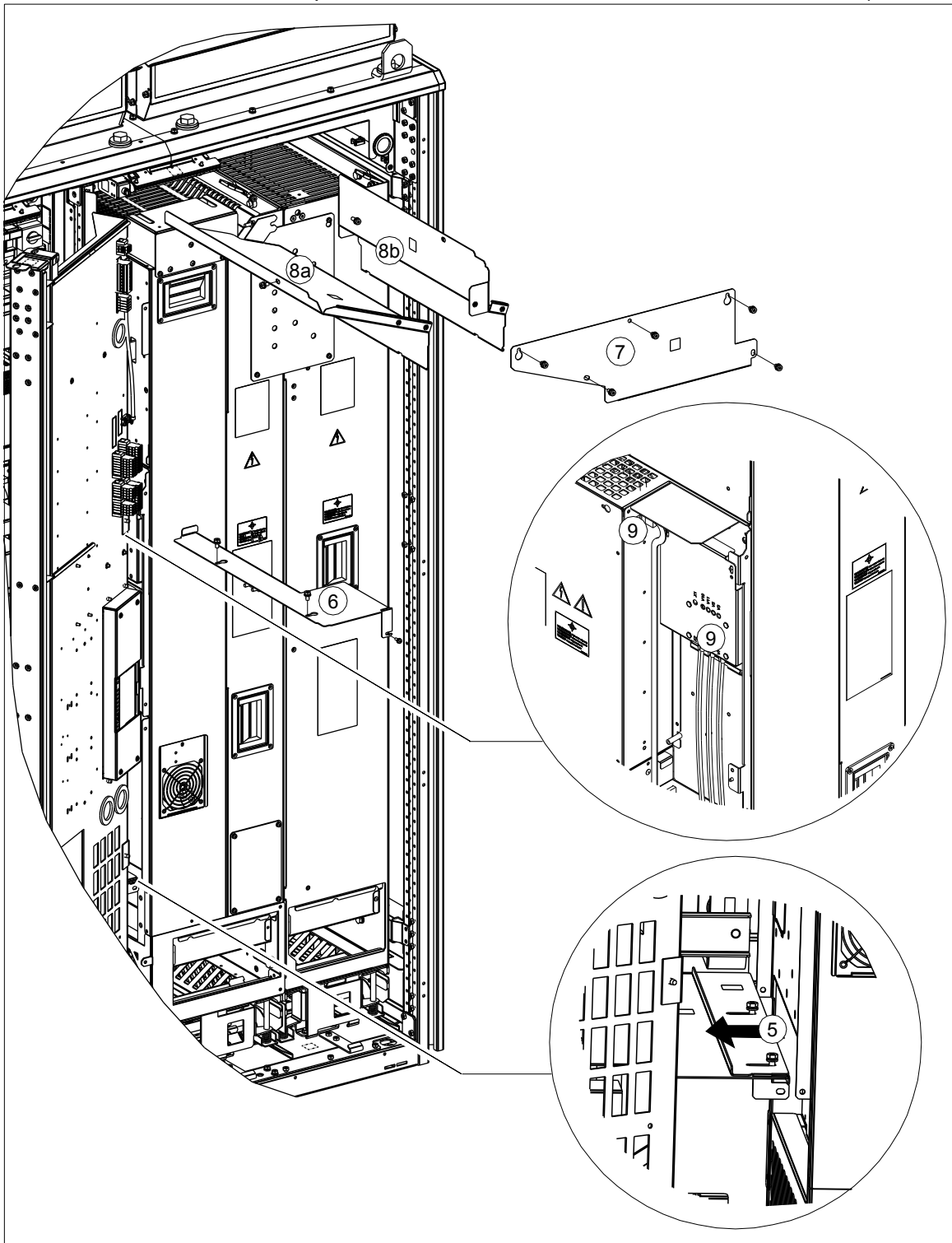



The connections between the line-side converter control unit and drive control unit are shown below. The drive control unit remains in its place when you remove the drive module.

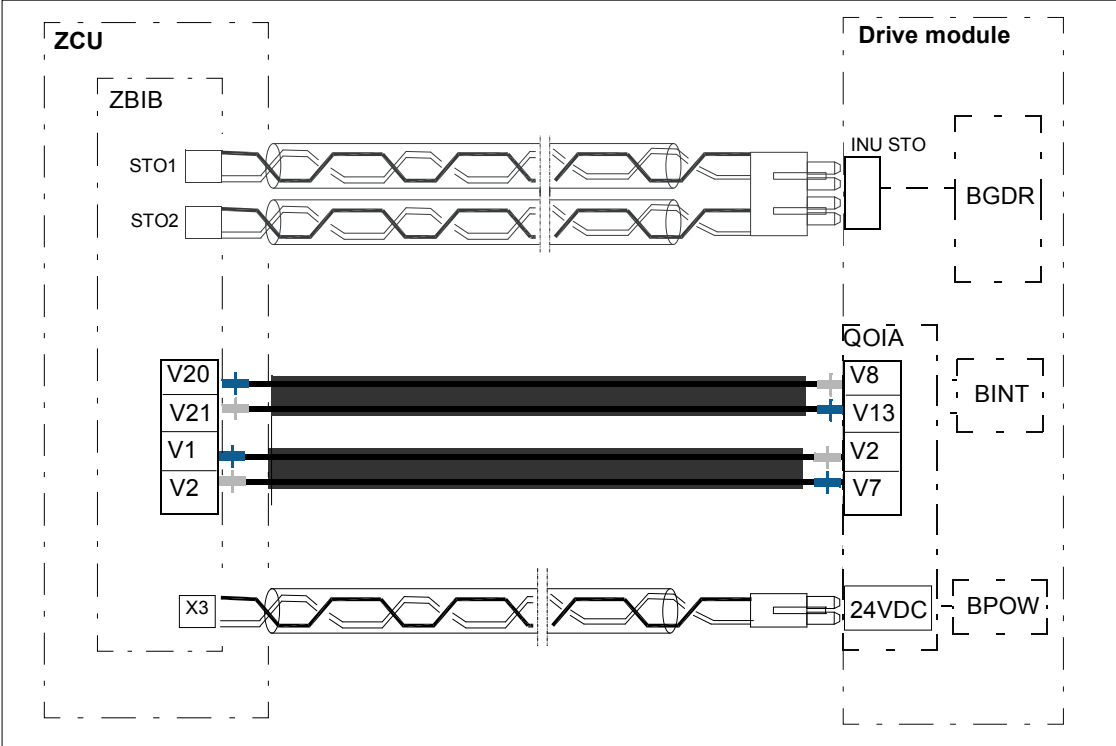

10. Loosen the M4 screws, lift the plastic shroud of the DC busbars up and remove it.
11. Disconnect the input power cabling busbars from the drive module busbar terminals. For drives with option +D150, disconnect the DC busbars also.
12. Disconnect the output power cabling and PE busbars from the drive module busbar terminals.

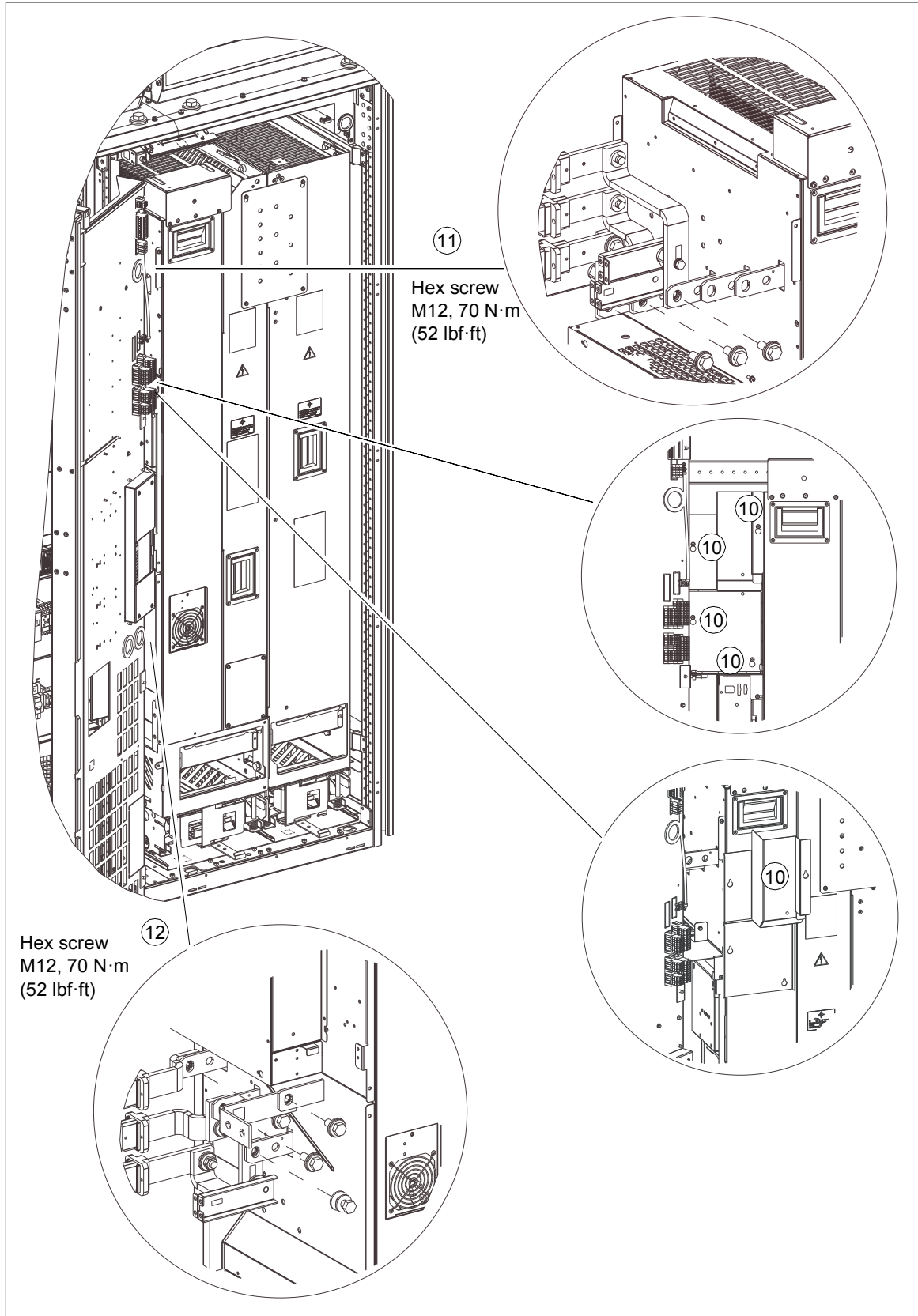

## 13. To disconnect the drive module from the LCL filter module:

- (13a) Remove the shroud.
- (13b) Remove the bolts that connect the power busbars.
- (13c) Remove the attaching bolt.
- (13d) Remove the shroud.
- (13e) Remove the bolts.
- (13f) Disconnect the power wire of the LCL filter fan from connector FAN3:LCL.

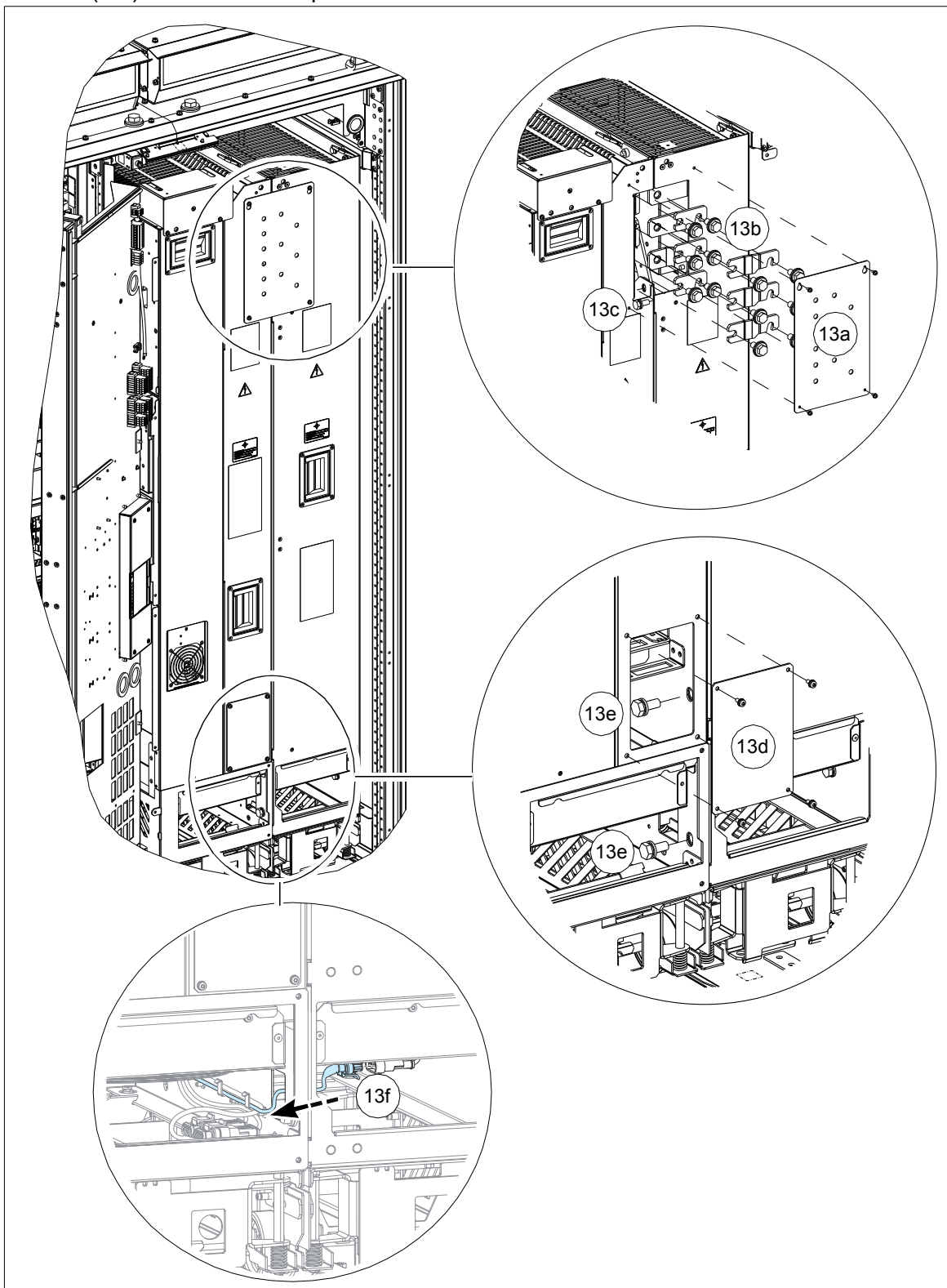

14. To open the support legs 90 degrees, press each leg a little down and turn it aside.
15. To remove the lower support bracket of the drive module, undo the two screws.
16. Adjust the extraction ramp to the correct height and attach it to the cabinet base with the two mounting screws of the support bracket that was removed.
17. For drives with marine construction (option +C121): Remove the bolts that attach the drive module to the cabinet frame at the lower part.

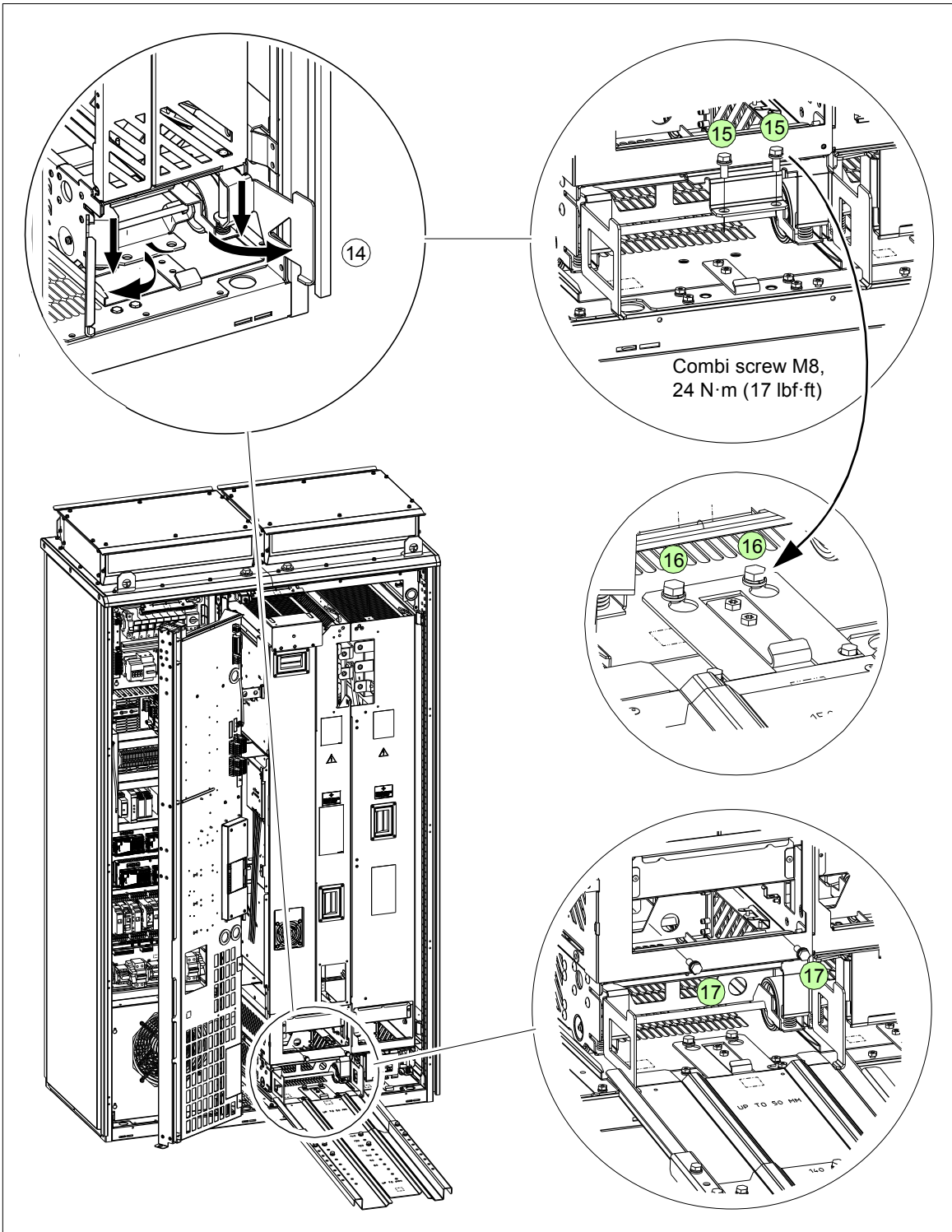

18. To remove the shroud on the charging circuit switch/contactor, undo the two mounting screws.
19. Unplug the connector and auxiliary contact wires of the charging circuit switch/contactor.
20. Undo the two bolts that attach drive module to the LCL filter module.
21. Undo the bolts that attach drive module from back to the cabinet frame.

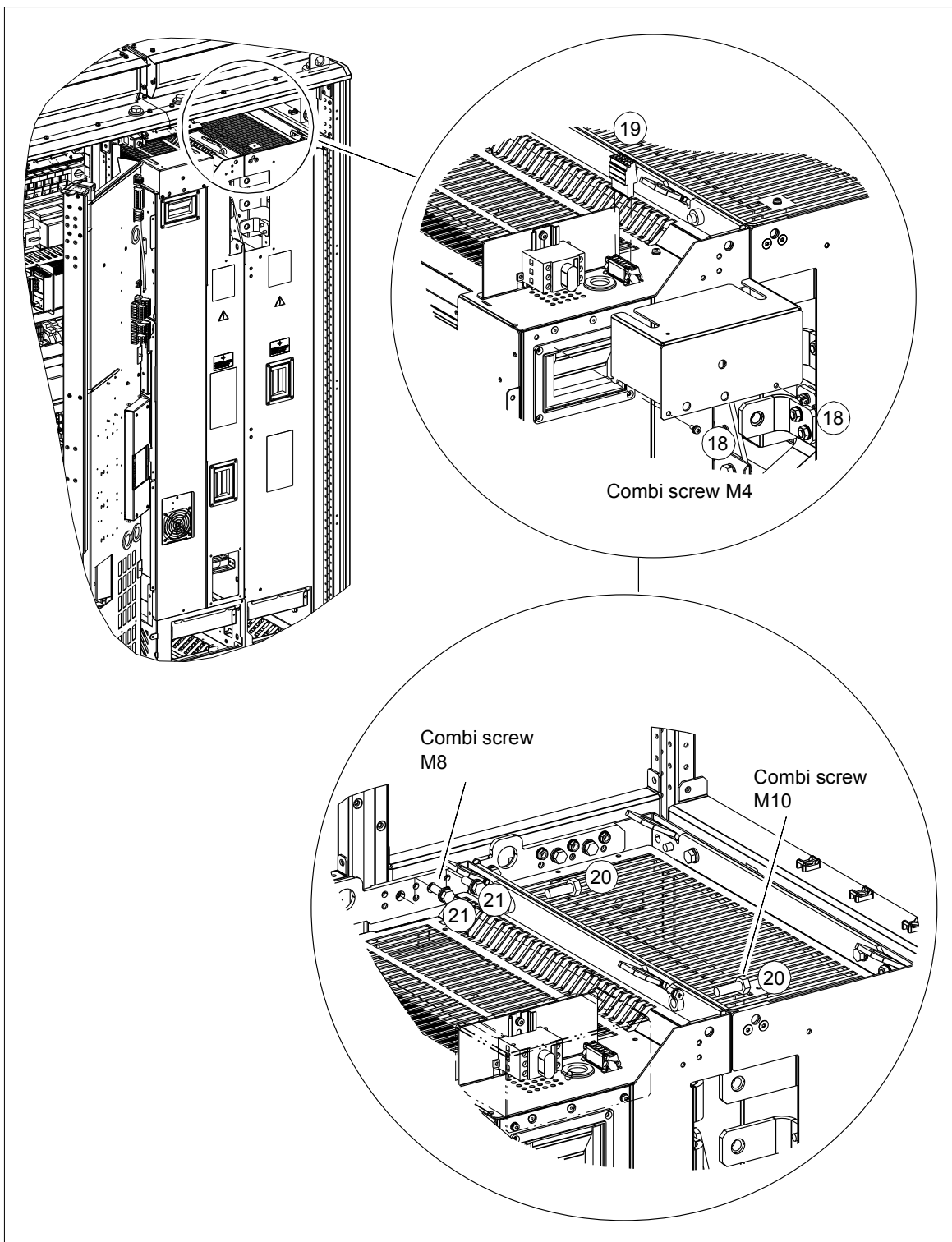

22. Attach the lifting lugs of the module to be removed to the cabinet lifting lug with chains.
23. Pull the module carefully out of the cabinet preferably with help from another person.
24. Before the module back wheels reach the attaching hook on the floor, open also the back support legs of the drive module by pressing each leg a little downwards and turning it aside. Close the legs when the module back wheels have passed the attaching hook.
25. Install the new module in reverse order.

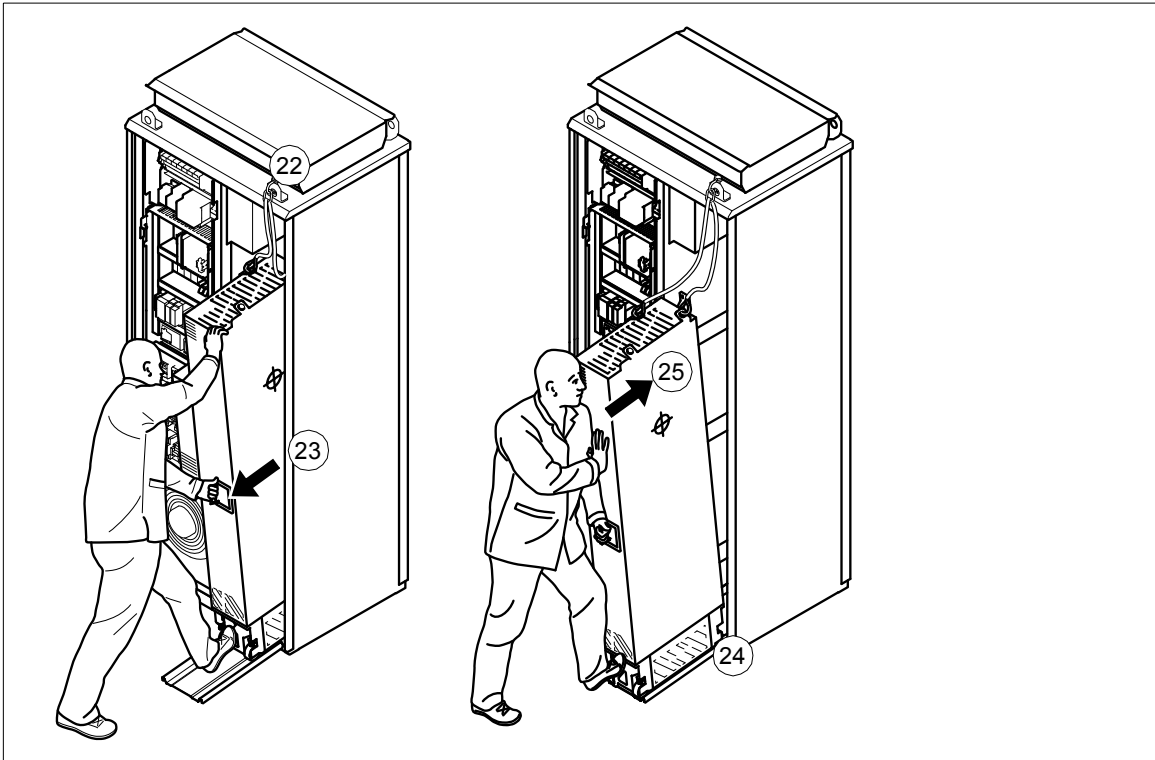

## ■ Replacing the LCL filter module

If LCL filter module is also to be replaced:

1. To open the support legs 90 degrees, press each leg a little down and turning it aside.
2. To remove the lower support bracket of the LCL filter module, undo the two screws.
3. Adjust the extraction ramp to the correct height and attach it to the cabinet base with the two mounting screws of the lower support bracket that was removed.
4. Undo the two lower screws that attach the LCL filter module to the cabinet from the right.
5. For drives with marine construction (option +C121): Undo the two lower screws that attach the LCL filter module to the cabinet frame from back.
6. Undo the 5 bolts that attach LCL filter module from back and from the right to the cabinet frame.

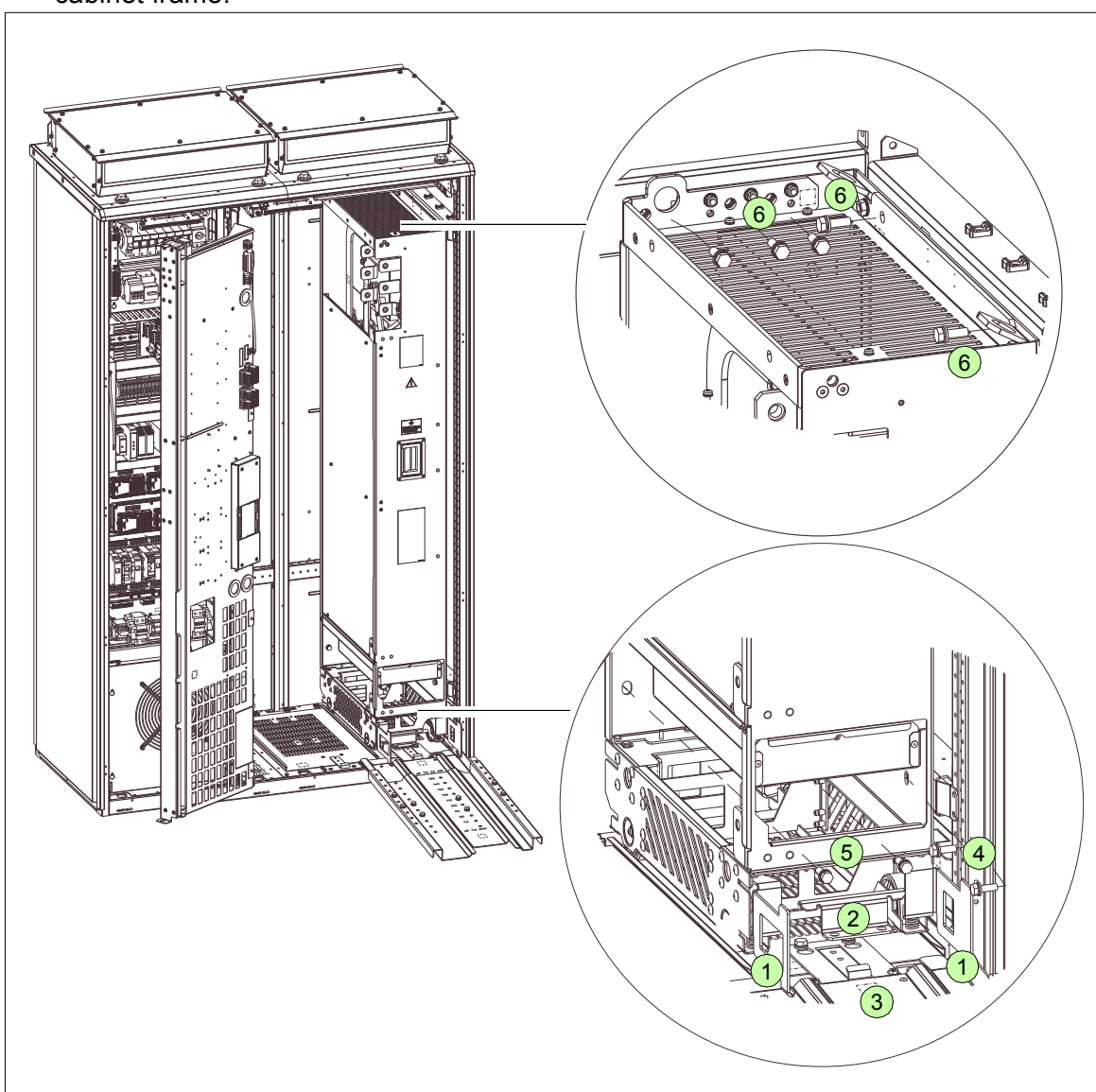

7. Attach the lifting lugs of the module to be removed to the cabinet lifting lug with chains.
8. Pull the LCL filter module carefully out of the cabinet preferably with help from another person.
9. Install new module in reverse order.

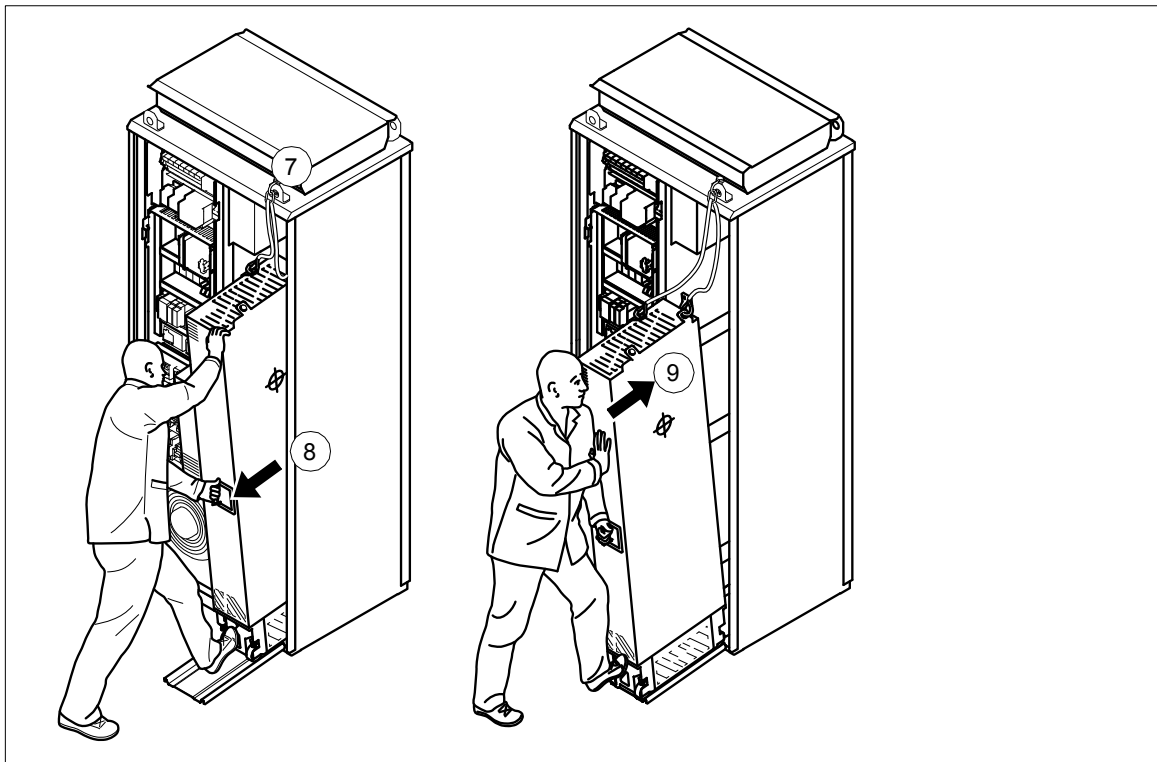

## Capacitors

The DC circuit of the drive modules of the drive contain several electrolytic capacitors. Their lifespan depends on the operating time of the drive, loading and ambient temperature. Capacitor life can be prolonged by lowering the ambient temperature.

Capacitor failure is usually followed by damage to the unit and an input cable fuse failure, or a fault trip. Contact ABB if capacitor failure is suspected. Replacements are available from ABB. Do not use other than ABB-specified spare parts.

### ■ Reforming the capacitors

The capacitors must be reformed if the drive has not been powered (either in storage or unused) for a year or more. See section *Type designation label* on page 62 for how to find out the manufacturing date from the serial number.

For information on reforming the capacitors, see *Converter module capacitor reforming instructions* (3BFE64059629 [English]), available on the Internet (go to <http://www.abb.com> and enter the document code in the Search field).



## Fuses

### ■ Replacing fuses (frame R8)



**WARNING!** Obey the instructions in chapter [Safety instructions](#). If you ignore them, injury or death, or damage to the equipment can occur.

1. Stop the drive (if running) and do the steps in section [Electrical safety precautions](#) (page 19) before you start the work.
2. Open the cabinet door.
3. Remove the fuse replacement handle.
4. Remove the shroud.
5. Remove the top mounting plate.
6. Pull out the fuses with the fuse handle and replace them with the new fuses.
7. Reinstall the mounting plate, shroud and fuse handle.

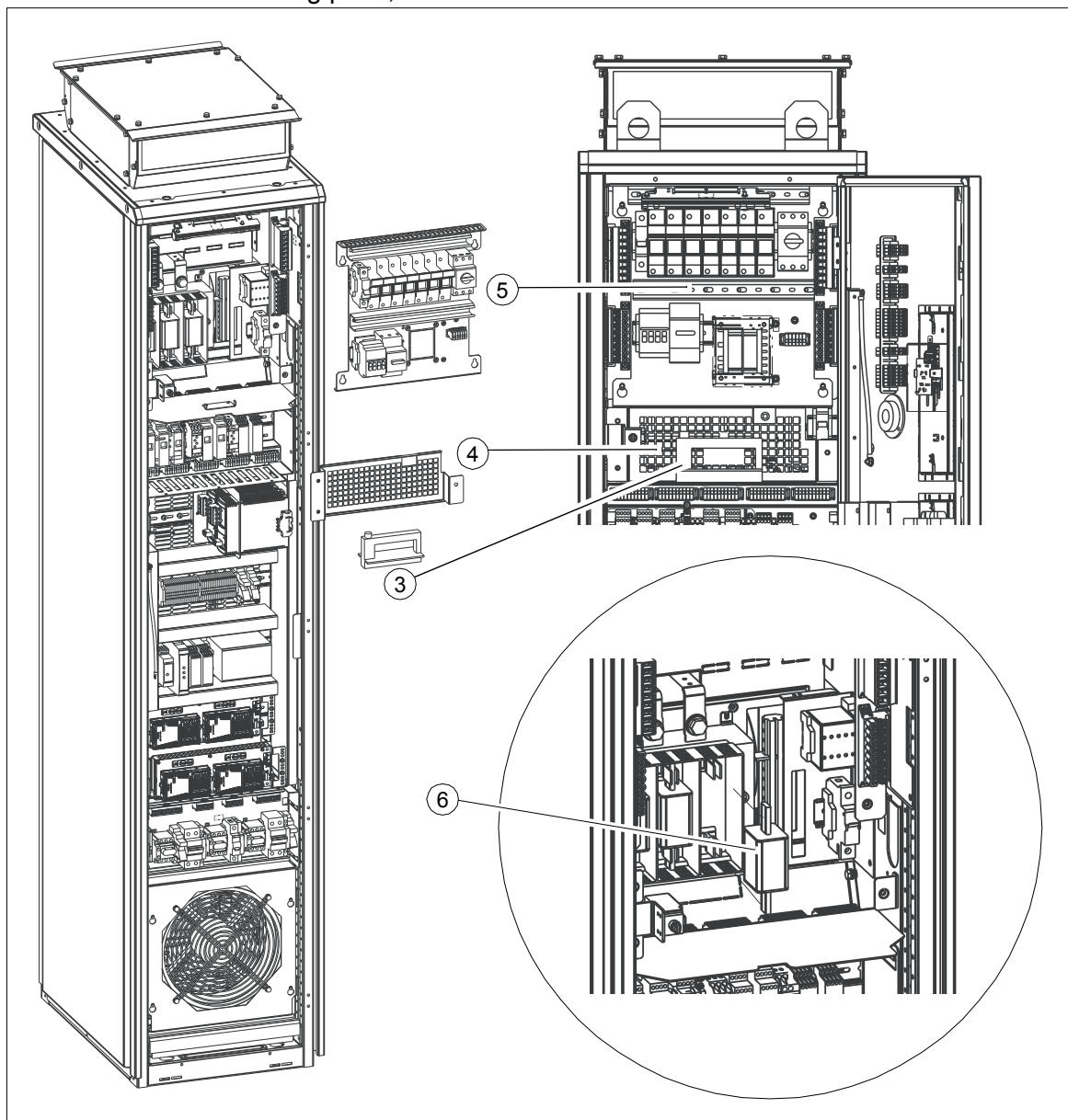

## ■ Replacing fuses (frame R11)



**WARNING!** Obey the instructions in chapter [Safety instructions](#). If you ignore them, injury or death, or damage to the equipment can occur.

1. Stop the drive (if running) and do the steps in section [Electrical safety precautions](#) (page 19) before you start the work.
2. Open the cabinet door.
3. Open the swing-out frame or remove the shroud – Bottom entry of cables:  
Marine drives (option +C121): Undo the three M6 screws on the left side of the swing-out frame. All drives: Undo the two M6 screws on the right side of the swing-out frame and open the swing-out frame, or remove the shroud if there is no swing-out frame.

Open the swing-out frame or remove the shroud – Top entry of cables:

Marine drives (option +C121): Undo the three M6 screws on the left side of the swing-out frame. All drives: Undo the two M6 screws on the right side of the swing-out frame and open the swing-out frame, or remove the shroud if there is no swing-out frame. Remove the plate under the swing-out frame (if present) or remove the shroud.

4. Remove the plastic shroud in front of the fuses.



**Note:** You can access the screws on the left side of the fuse shroud easier if you open the swing-out frame slightly and use the gap between the swing-out frame and cabinet frame to access the screws.

5. Slacken the nuts of the headless screws of the fuses so that you can slide out the fuse blocks. Make a note of the order of the washers on the screws.
6. Remove the screws, nuts and washers from the old fuses and attach them to the new fuses. Make sure to keep the washers in the original order.
7. Insert the new fuses into their slots in the cubicle.
8. Tighten the nuts to torque as follows:
  - Cooper-Bussmann fuses: 50 N·m (37 lbf·ft) if size 3; 40 N·m (30 lbf·ft) if size 2
  - Mersen (Ferraz-Shawmut): 46 N·m (34 lbf·ft) if size 33; 26 N·m (19 lbf·ft) if size 32
  - Other fuses: Refer to the fuse manufacturer's instructions.
9. Reinstall the shrouds and mounting plate if removed earlier. Close the swing-out frame. Close the cabinet door.

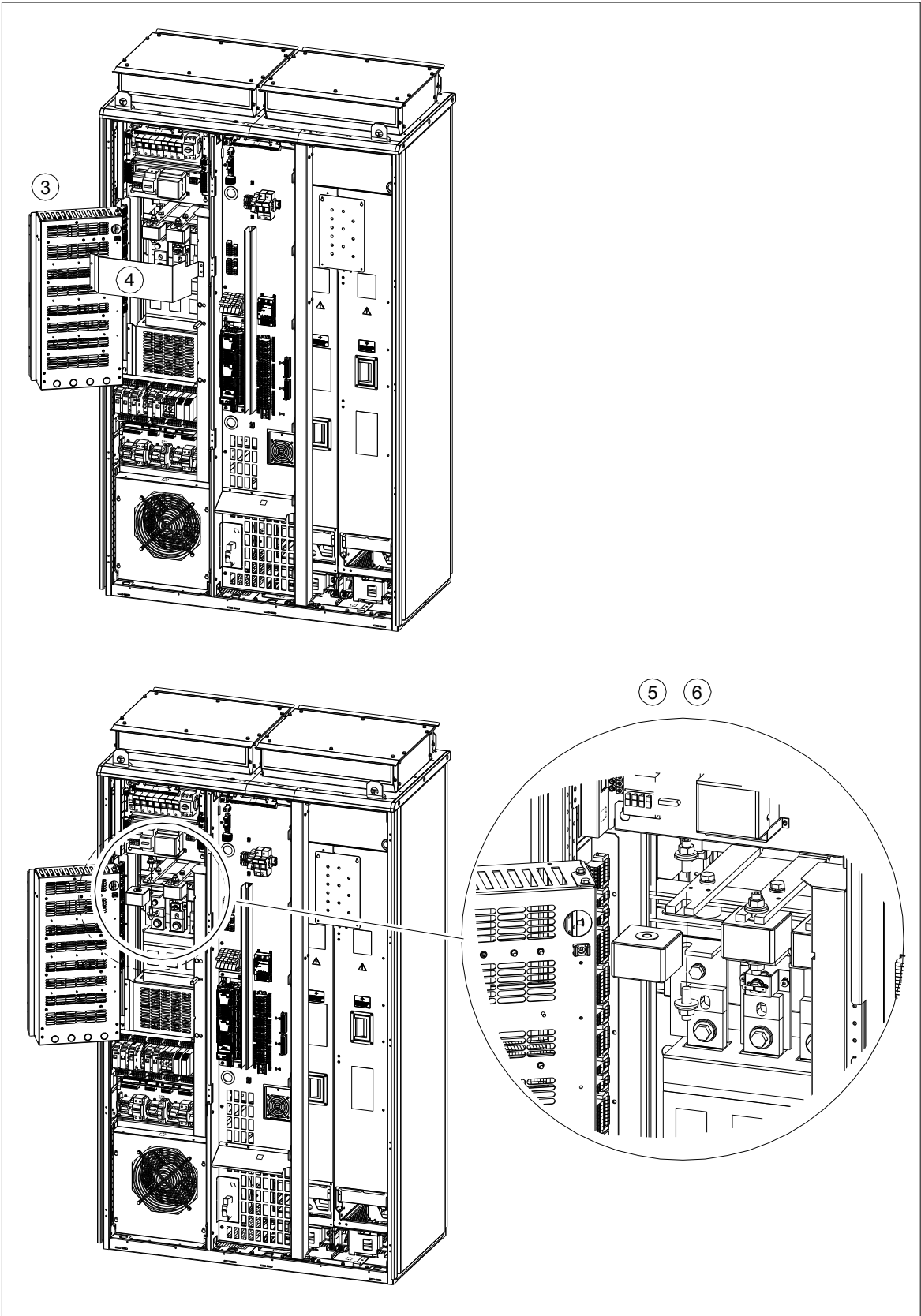

## Control panel

### ■ Replacing the battery

1. Turn the lid on the back of the panel counter-clockwise until the lid opens.
2. Replace the battery with a new CR2032 battery.
3. Put the lid back and tighten it by turning it clockwise.
4. Dispose of the old battery according to local disposal rules or applicable laws.



### ■ Cleaning

See *ACx-AP-x assistant control panels user's manual* [3AUA0000085685 (English)].

## Replacing the control unit battery



**WARNING!** Obey the instructions in chapter [Safety instructions](#). If you ignore them, injury or death, or damage to the equipment can occur.

1. Stop the drive and do the steps in section [Electrical safety precautions](#) on page 19 before you start the work.

To replace the control unit battery:

1. Remove the M4x8 (T20) screws at the ends of the control unit.
2. To see the battery, remove the XD2D terminal block.
3. Carefully lift the edge of the control unit cover on the side with the I/O terminal blocks.
4. Carefully pull the battery out of the battery holder.
5. Carefully put a new CR2032 battery into the battery holder.
6. Close the control unit cover.
7. Tighten the M4x8 (T20) screws.
8. Install the XD2D terminal block.

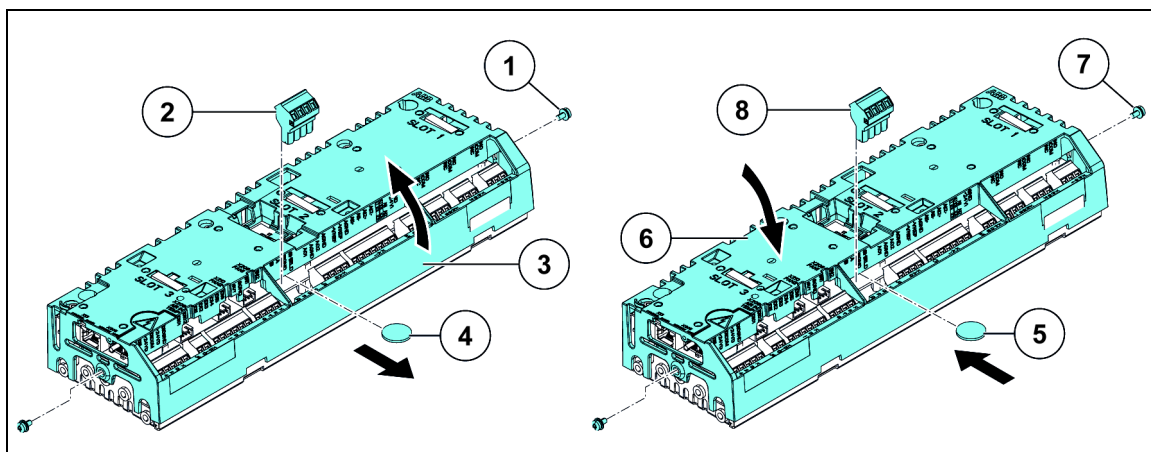

## Memory unit

When a drive is replaced, the parameter settings can be retained by transferring the memory unit from the defective drive to the new drive. One memory unit is located on the drive control unit (motor-side converter control unit), see page 152, another on the line-side converter control unit.



**WARNING!** Do not remove or insert the memory unit when the drive module is powered.

---

After power-up, the drive scans the memory unit. If a different control program or different parameter settings are detected, they are copied to the drive. This can take several minutes.

### ■ Replacing the memory unit of the motor-side converter control unit (frame R8)

---



**WARNING!** Obey the instructions in chapter [Safety instructions](#). If you ignore them, injury or death, or damage to the equipment can occur.

---

1. Stop the drive and do the steps in section [Electrical safety precautions](#) on page 19 before you start the work.
2. Open the cabinet door and swing-out frame or remove the shroud if there is no swing-out frame. The control unit is located behind swing-out frame or shroud.

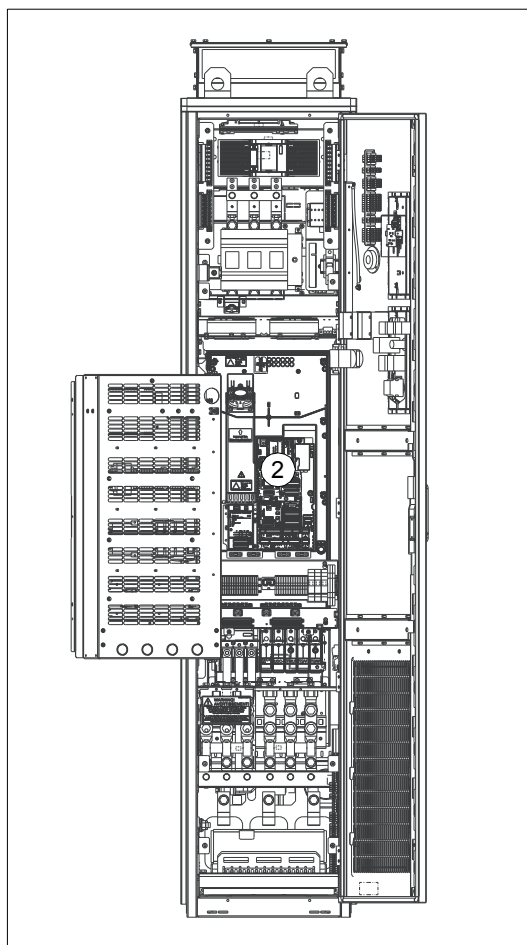

- Undo the memory unit mounting screw and take the memory unit out. Replace the unit in reverse order. **Note:** There is a spare screw next to the memory unit slot.

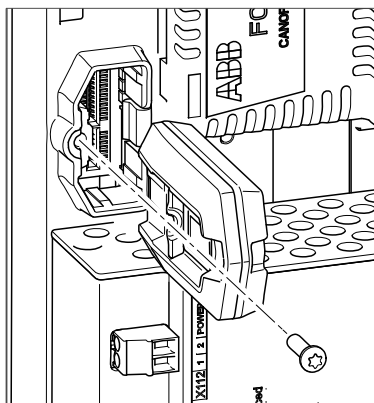

### ■ Replacing the memory unit of the motor-side converter control unit (frame R11)



**WARNING!** Obey the instructions in chapter [Safety instructions](#). If you ignore them, injury or death, or damage to the equipment can occur.

- Stop the drive and do the steps in section [Electrical safety precautions](#) on page 19 before you start the work.
- Open the cabinet doors. The control unit is located on the module-side swing-out frame. For the location, see also [Cabinet layout](#).

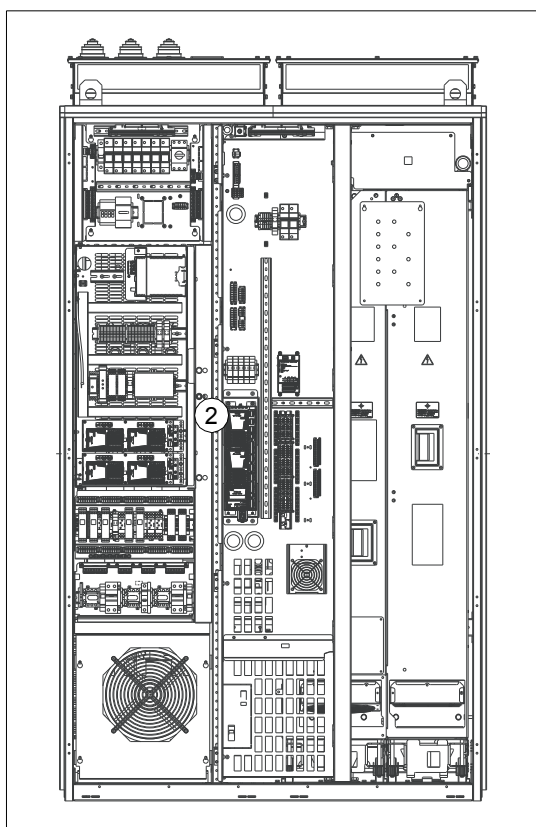

3. Remove the mounting screw.
4. Pull the memory unit out.
5. Install the new memory unit in reverse order. **Note:** There is a spare screw next to the memory unit slot.

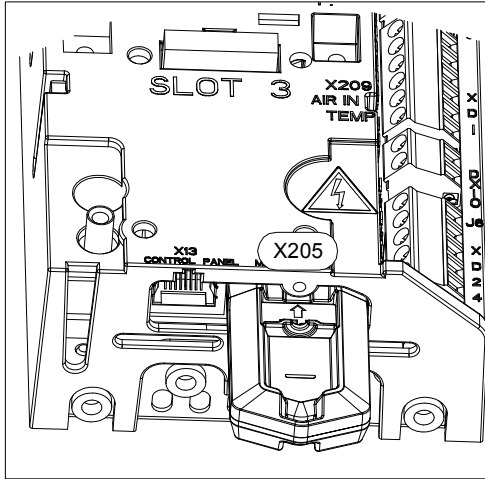

### ■ Replacing the memory unit of the line-side converter control unit (frame R11)



**WARNING!** Obey the instructions in chapter [Safety instructions](#). If you ignore them, injury or death, or damage to the equipment can occur.

1. Stop the drive and do the steps in section [Electrical safety precautions](#) on page 19 before you start the work.
2. To remove the marine supports in drives with option +C121, see [Replacing the drive and LCL filter modules \(frame R11\)](#).
3. To open the module section swing-out frame, undo the M10 bolts from top and bottom (4 pcs). See [Replacing the drive and LCL filter modules \(frame R11\)](#).
4. Remove the cover on the memory unit.
5. Pull the memory unit out.
6. Insert the new memory unit in reverse order.

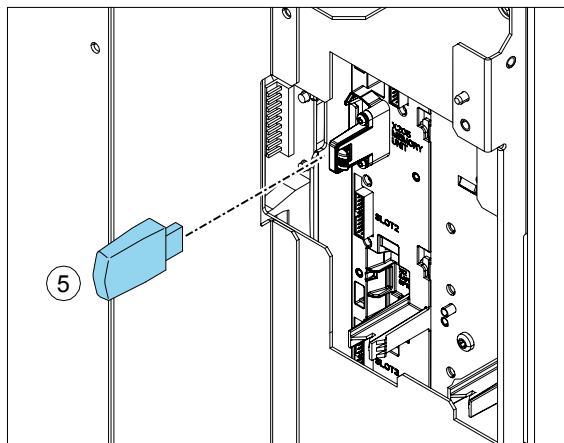
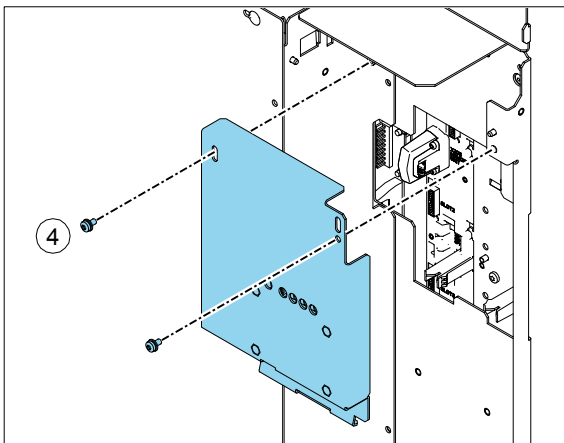



# 13

## Technical data

### Contents of this chapter

This chapter contains the technical specifications of the drive, for example, the ratings, fuse data, sizes and technical requirements, provisions for fulfilling the requirements for CE and other markings.

### Marine type-approved drives (option +C132)

See *ACS880 +C132 marine type-approved cabinet-built drives supplement* (3AXD50000039629 [English]) for the ratings, marine-specific data and reference to valid marine type approvals.

### Ratings

The nominal ratings for the drives with 50 Hz and 60 Hz supply are given below. The symbols are described in section [Definitions](#) on page 219.

#### ■ IEC ratings

Drive type ACS880-37-	Frame size	Input current	Nominal ratings				Output ratings			
							Light-overload use		Heavy-duty use	
			$I_1$	$I_2$	$I_{max}$	$P_N$	$S_N$	$I_{Ld}$	$P_{Ld}$	$I_{Hd}$
A	A	A	kW	kVA	A	kW	A	kW		
$U_N = 400\text{ V}$										
0105A-3	R8	88	105	148	55	73	100	55	87	45
0145A-3	R8	120	145	178	75	100	138	75	105	55
0169A-3	R8	144	169	247	90	117	161	90	145	75
0206A-3	R8	176	206	287	110	143	196	110	169	90

Drive type ACS880-37-	Frame size	Input current	Nominal ratings				Output ratings			
							Light-overload use		Heavy-duty use	
			$I_1$	$I_2$	$I_{max}$	$P_N$	$S_N$	$I_{Ld}$	$P_{Ld}$	$I_{Hd}$
A	A	A	kW	kVA	A	kW	A	kW		
0293A-3	R11	257	293	418	160	203	278	160	246	132
0363A-3	R11	321	363	498	200	251	345	200	293	160
0442A-3	R11	401	442	545	250	306	420	250	363	200
0505A-3	R11	401	505	560	250	350	480	250	363	200
0585A-3	R11	505	585	730	315	405	556	315	442	250
0650A-3	R11	569	650	730	355	450	618	355	505	250
<b><math>U_N = 500\text{ V}</math></b>										
0101A-5	R8	71	101	148	55	87	91	55	77	45
0124A-5	R8	96	124	178	75	107	118	75	96	55
0156A-5	R8	115	156	247	90	135	148	90	124	75
0180A-5	R8	141	180	287	110	156	171	110	156	90
0260A-5	R11	205	260	418	160	225	247	160	240	132
0361A-5	R11	257	361	542	200	313	343	200	260	160
0414A-5	R11	321	414	542	250	359	393	250	361	200
0460A-5	R11	404	460	560	315	398	450	315	414	250
0503A-5	R11	455	503	560	355	436	492	355	460	315
<b><math>U_N = 690\text{ V}</math></b>										
0174A-7	R11	149	174	274	160	208	165	160	142	132
0210A-7	R11	186	210	384	200	251	200	200	174	160
0271A-7	R11	232	271	411	250	324	257	250	210	200
0330A-7	R11	293	330	480	315	394	320	315	271	250
0370A-7	R11	330	370	520	355	442	360	355	330	315
0430A-7	R11	375	430	520	400	514	420	400	370	355

3AXD1000425795

**UL (NEC) ratings**

Drive type ACS880-37-	Frame size	Input current	Max. current	App. power	Output ratings			
					Light-overload use		Heavy-duty use	
					$I_1$	$I_{max}$	$S_N$	$I_{Ld}$
A	A	kVA	A	hp	A	hp		
<b><math>U_N = 480\text{ V}</math></b>								
0101A-5	R8	74	148	87	96	75	77	60
0124A-5	R8	100	178	107	124	100	96	75
0156A-5	R8	120	247	135	156	125	124	100
0180A-5	R8	147	287	156	180	150	156	125
0260A-5	R11	205	418	225	260	200	240	200
0302A-5	R11	239	498	262	302	250	260	200
0361A-5	R11	257	542	313	361	300	302	250
0414A-5	R11	321	542	359	414	350	361	300
0460A-5	R11	404	560	398	430	350	414	350
0503A-5	R11	455	560	436	483	400	483	400

Drive type ACS880-37-	Frame size	Input current	Max. current	App. power	Output ratings			
					Light-overload use		Heavy-duty use	
					$I_1$	$I_{\max}$	$S_N$	$I_{Ld}$
		A	A	kVA	A	hp	A	hp
$U_N = 600\text{ V}$								
0174A-7	R11	146	274	208	168	175	144	150
0210A-7	R11	166	384	251	192	200	168	175
0271A-7	R11	208	411	324	242	250	192	200
0330A-7	R11	250	480	394	289	300	242	250
0370A-7	R11	291	520	442	336	350	289	300
0430A-7	R11	375	520	514	412	450	336	350

3AXD10000425795

## ■ Definitions

- $I_1$  Nominal rms input current at 40 °C (104 °F)
- $I_2$  Continuous rms output current. No overload capability at 40 °C (104 °F)
- $I_{\max}$  Maximum output current. Available for 10 seconds at start, then as long as allowed by drive temperature.
- $P_N$  Typical motor power in no-overload use
- $S_N$  Apparent power in no-overload use
- $I_{Ld}$  Continuous rms output current allowing 10% overload for 1 minute every 5 minutes.  
<sup>1)</sup> No overload
- $P_{Ld}$  Typical motor power in light-overload use
- $I_{Hd}$  Continuous rms output current allowing 50% overload for 1 minute every 5 minutes.
- $P_{Hd}$  Typical motor power in heavy-duty use

**Note 1:** The ratings apply at an ambient temperature of 40 °C (104 °F).

**Note 2:** To achieve the rated motor power given in the table, the rated current of the drive must be higher than or equal to the rated motor current.

The DriveSize dimensioning tool available from ABB is recommended for selecting the drive, motor and gear combination.

## Derating

### Ambient temperature derating

In the temperature range +40...50 °C (+104...122 °F), the rated output current is derated by 1% for every added 1 °C (1.8 °F).

To calculate the output current, multiply the current in the ratings table by the derating factor ( $k$ ):

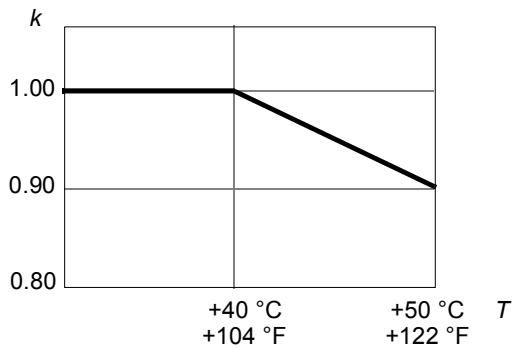

For example:

Temperature	Derated current		
	$I_2$	$I_{Ld}$	$I_{Hd}$
40 °C (104 °F)	$I_2$	$I_{Ld}$	$I_{Hd}$
45 °C (113 °F)	$0.95 \cdot I_2$	$0.95 \cdot I_{Ld}$	$0.95 \cdot I_{Hd}$
50 °C (122 °F)	$0.90 \cdot I_2$	$0.90 \cdot I_{Ld}$	$0.90 \cdot I_{Hd}$

### Altitude derating

At altitudes from 1000 to 4000 m (3281 to 13123 ft) above sea level, the output current derating is 1% for every 100 m (328 ft). If ambient temperature is below +40 °C (+104 °F), the derating can be reduced by 1.5% for every 1 °C reduction in temperature.

For a more accurate derating, use the DriveSize PC tool. A few altitude derating curves are shown below.

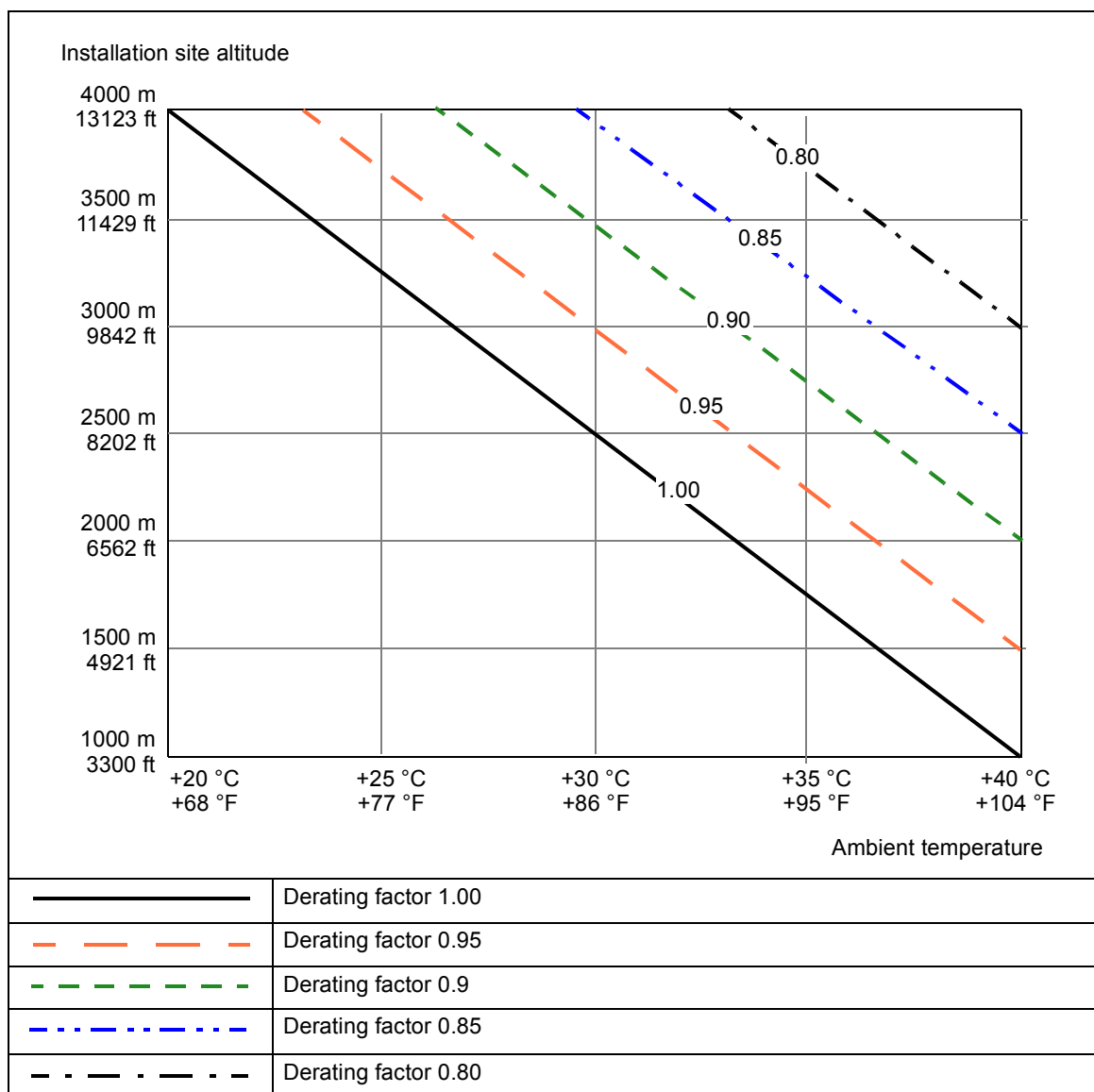

### Deratings for special settings in the drive control program

Enabling special settings in the motor-side converter control program can require output current derating.

#### Ex motor, sine filter, low noise

- drive is used with an ABB motor for explosive atmospheres (Ex) and **EX motor** in parameter **95.15 Special HW settings** is enabled
- sine filter option +E206 is selected and **ABB sine filter** in parameter **95.15 Special HW settings** is enabled
- **Low noise optimization** is selected in parameter **97.09 Switching freq mode**.

For non-ABB Ex motors, contact ABB.

**Note:** If Ex motors are used together with sine filters, EX motor in Parameter **95.15 Special HW settings** is disabled and ABB Sine filter in Parameter **95.15 Special HW settings** is enabled. Obey the instructions of the motor manufacturer.

Drive type ACS880-37-	Output ratings for special settings											
	Ex motor (ABB Ex motor)				ABB sine filter				Low noise mode			
	Nominal use		Light-duty use	Heavy-duty use	Nominal use		Light-duty use	Heavy-duty use	Nominal use		Light-duty use	Heavy-duty use
	$I_N$	$P_N$	$I_{Ld}$	$I_{Hd}$	$I_N$	$P_N$	$I_{Ld}$	$I_{Hd}$	$I_N$	$P_N$	$I_{Ld}$	$I_{Hd}$
A	kW	A	A	A	kW	A	A	A	kW	A	A	
<b><math>U_N = 400\text{ V}</math></b>												
0105A-3	105	55	100	105	105	55	100	87	105		100	87
0145A-3	145	75	138	145	145	75	138	105	145		138	105
0169A-3	169	90	161	169	169	90	161	145	169		161	145
0206A-3	206	110	196	196	206	110	196	169	206		196	169
0293A-3	234	132	222	234	264	160	251	221	217	132	204	180
0363A-3	278	160	264	278	327	200	310	264	258	160	243	215
0442A-3	345	200	328	345	398	250	378	327	320	200	301	256
0505A-3	420	250	399	345	455	250	432	327	390	250	367	317
0585A-3	480	315	456	420	527	315	500	398	445	250	419	317
0650A-3	556	315	528	480	585	355	556	455	516	315	485	386
<b><math>U_N = 500\text{ V}</math></b>												
0101A-5	101	45	91	45	101	45	91	45	101		91	77
0124A-5	124	55	118	55	124	55	118	55	124		118	96
0156A-5	156	75	148	75	156	75	148	75	156		148	124
0180A-5	180	90	171	90	180	90	171	90	180		171	156
0260A-5	228	132	217	171	216	132	205	162	212	132	199	157
0302A-5	247	160	235	228	234	160	222	216	229	160	216	210
0361A-5	287	250 (hp)	287	247	272	250 (hp)	272	234	266	250 (hp)	264	227
0414A-5	343	200	326	247	325	200	309	234	318	200	300	227
0460A-5	393	250	373	343	373	250	354	325	365	250	343	315
0503A-5	437	315	428	393	414	315	405	373	406	250	393	362
<b><math>U_N = 690\text{ V}</math></b>												
0174A-7	125	132	119	105	128	132	122	107	66	75	63	55
0210A-7	153	160	145	125	157	160	149	128	81	90	77	66
0271A-7	185	200	176	153	189	200	180	157	98	110	93	81
0330A-7	238	250	226	185	244	250	231	189	126	132	119	98
0370A-7	290	315	282	238	297	315	288	244	154	160	149	126
0430A-7	326	355	317	290	333	355	324	297	172	200	167	153

3AXD10000425795

$U_N$	Nominal voltage of the drive
$I_N$	Continuous rms output current. No overload capability at 40 °C (104 °F)
$P_N$	Typical motor power in no-overload use.
$I_{Ld}$	Continuous rms output current allowing 10% overload for 1 minute every 5 minutes
$I_{Hd}$	Continuous rms output current allowing 50% overload for 1 minute every 5 minutes
The ratings apply at an ambient temperature of 40 °C (104 °F).	

## High speed mode

Selection **High speed mode** of parameter 95.15 **Special HW settings** improves control performance at high output frequencies. ABB recommends it to be selected with output frequency of 120 Hz and above.

This table gives the drive module ratings for 120 Hz output frequency and the maximum output frequency for the drive ratings when **High speed mode** in parameter **95.15 Special HW settings** is enabled: With output frequencies smaller than this recommended maximum output frequency, the current derating is less than the values given in the table. Contact ABB for operation above the recommended maximum output frequency or for the output current derating with output frequencies above 120 Hz and below the maximum output frequency.

Drive type ACS880-37-	Deratings with selection High speed mode of parameter 95.15 Special HW settings							
	120 Hz output frequency (no derating)				Maximum output frequency 500 Hz			
	Nominal use		Light-duty use	Heavy-duty use	Nominal use		Light-duty use	Heavy-duty use
	$I_N$	$P_N$	$I_{Ld}$	$I_{Hd}$	$I_N$	$P_N$	$I_{Ld}$	$I_{Hd}$
A	kW	A	A	A	kW	A	A	
<b><math>U_N = 400\text{ V}</math></b>								
0105A-3	105	55	100	87	105		100	87
0145A-3	145	75	138	105	145		138	105
0169A-3	169	90	161	145	156		148	122
0206A-3	206	110	196	169	192		180	155
0293A-3	246	132	234	206	201	110	193	170
0363A-3	293	160	278	246	240	132	229	203
0442A-3	363	200	345	293	297	200	284	241
0505A-3	442	250	420	363	362	250	346	299
0585A-3	505	250	480	363	413	250	395	299
0650A-3	585	315	556	442	479	315	458	364
<b><math>U_N = 500\text{ V}</math></b>								
0101A-5	101	55	91	77	101		91	77
0124A-5	124	75	118	96	124		118	96
0156A-5	156	90	148	124	144		136	87
0180A-5	180	110	171	156	169		160	147
0260A-5	240	132	228	180	196	132	188	148
0302A-5	260	160	247	240	213	160	203	198
0361A-5	302	250 (hp)	302	260	247	200 (hp)	249	214
0414A-5	361	200	343	260	295	250	283	214
0460A-5	414	250	393	361	339	250	324	297
0503A-5	460	315	450	414	376	315	371	341
<b><math>U_N = 690\text{ V}</math></b>								
0174A-7	142	132	135	119	82	75	78	68
0210A-7	174	160	165	142	100	110	95	82
0271A-7	210	200	200	174	121	132	115	100
0330A-7	271	250	257	210	156	160	148	121
0370A-7	330	315	320	271	190	200	184	156

3AXD10000425795

$f$	Output frequency
-----	------------------

$f_{\max}$	Maximum output frequency with High speed mode
$U_N$	Nominal voltage of the drive
$I_N$	Continuous rms output current. No overload capability at 40 °C (104 °F)
$P_N$	Typical motor power in no-overload use.
$I_{Ld}$	Continuous rms output current allowing 10% overload for 1 minute every 5 minutes
$P_{Ld}$	Typical motor power for light-overload use.
$I_{Hd}$	Continuous rms output current allowing 50% overload for 1 minute every 5 minutes
The ratings apply at an ambient temperature of 40 °C (104 °F).	

## Fuses (IEC)

The drive is equipped with aR fuses listed below as standard.

Drive type ACS880-37-	Input current (A)	Ultrarapid (aR) fuses (one fuse per phase)					
		A	A <sup>2</sup> s	V	Manufacturer	Type	Size
<b><math>U_N = 400\text{ V}</math></b>							
0105A-3	88	160	8250	690	Bussmann	170M3814D	1
0145A-3	120	250	31000	690	Bussmann	170M3816D	1
0169A-3	144	250	31000	690	Bussmann	170M3816D	1
0206A-3	176	315	52000	690	Bussmann	170M3817D	1
0293A-3	257	500	145000	690	Bussmann	170M5410	2
0363A-3	321	630	210000	690	Bussmann	170M6410	3
0442A-3	401	700	300000	690	Bussmann	170M6411	3
0505A-3	401	800	465000	690	Bussmann	170M6412	3
0585A-3	505	900	670000	690	Bussmann	170M6413	3
0650A-3	569	1000	945000	690	Bussmann	170M6414	3
<b><math>U_N = 500\text{ V}</math></b>							
0101A-5	71	160	8250	690	Bussmann	170M3814D	1
0124A-5	96	250	31000	690	Bussmann	170M3816D	1
0156A-5	115	250	31000	690	Bussmann	170M3816D	1
0180A-5	141	315	52000	690	Bussmann	170M3817D	1
0260A-5	205	400	74000	690	Bussmann	170M5408	2
0361A-5	257	630	210000	690	Bussmann	170M6410	3
0414A-5	321	700	300000	690	Bussmann	170M6411	3
0460A-5	404	700	300000	690	Bussmann	170M6411	3
0503A-5	455	800	465000	690	Bussmann	170M6412	3
<b><math>U_N = 690\text{ V}</math></b>							
0174A-7	149	400	74000	690	Bussmann	170M5408	2
0210A-7	186	400	74000	690	Bussmann	170M5408	2
0271A-7	232	500	105000	690	Bussmann	170M5410	2
0330A-7	293	630	210000	690	Bussmann	170M6410	3
0370A-7	330	630	210000	690	Bussmann	170M6410	3
0430A-7	375	700	300000	690	Bussmann	170M6411	3

3AXD10000425795

**Note 1:** See also [Implementing thermal overload and short-circuit protection](#) on page 97.

**Note 2:** Fuses with higher current rating than the recommended ones must not be used. Fuses with lower current rating can be used.

**Note 3:** Fuses from other manufacturers can be used if they meet the ratings and the melting curve of the fuse does not exceed the melting curve of the fuse mentioned in the table.



## Fuses (UL)

The drive with options +C129 and +C134 is equipped for branch circuit protection per NEC with standard fuses listed below. The fuses restrict drive damage and prevent damage to adjoining equipment in case of a short-circuit inside the drive. **Check that the operating time of the fuse is below 0.1 seconds.** The operating time depends on the fuse type, supply network impedance and the cross-sectional area, material and length of the supply cable. The fuses must be of the “non-time delay” type. Obey local regulations.

Drive type ACS880-37-	Input current A	Fuse (one fuse per phase)				
		A	V	Manufacturer	Type	UL class / Size
$U_N = 400\text{ V}$						
0105A-3	88	250	600	Bussmann	DFJ-250	Class J
0145A-3	120	250	600	Bussmann	DFJ-250	Class J
0169A-3	144	250	600	Bussmann	DFJ-250	Class J
0206A-3	176	300	600	Bussmann	DFJ-300	Class J
0293A-3	257	500	690	Bussmann	170M5410	2
0363A-3	321	630	690	Bussmann	170M6410	3
0442A-3	401	700	690	Bussmann	170M6411	3
0505A-3	401	800	690	Bussmann	170M6412	3
0585A-3	505	900	690	Bussmann	170M6413	3
0650A-3	569	1000	690	Bussmann	170M6414	3
$U_N = 480\text{ V}$						
0101A-5	74	250	600	Bussmann	DFJ-250	Class J
0124A-5	100	250	600	Bussmann	DFJ-250	Class J
0156A-5	120	250	600	Bussmann	DFJ-250	Class J
0180A-5	147	300	600	Bussmann	DFJ-300	Class J
0260A-5	205	400	600	Bussmann	170M5408	2
0302A-5	239	500	690	Bussmann	170M5410	2
0361A-5	257	630	690	Bussmann	170M6410	3
0414A-5	321	700	690	Bussmann	170M6411	3
0460A-5	404	700	690	Bussmann	170M6411	3
0503A-5	455	800	690	Bussmann	170M6412	3
$U_N = 600\text{ V}$						
0174A-7*	146	315	600	Bussmann	170M4410	1
0210A-7	166	400	690	Bussmann	170M5408	2
0271A-7	208	500	690	Bussmann	170M5410	2
0330A-7	250	630	690	Bussmann	170M6410	3
0370A-7*	291	700	690	Bussmann	170M6411	3
0430A-7	375	700	690	Bussmann	170M6411	3

3AXD10000425795

**Note 1:** See also [Implementing thermal overload and short-circuit protection](#) on page 97.

**Note 2:** Fuses with higher current rating than the recommended ones must not be used. Fuses with lower current rating can be used.

**Note 3:** Fuses from other manufacturers can be used if they meet the ratings and the melting curve of the fuse does not exceed the melting curve of the fuse mentioned in the table.

## Dimensions and weights

Frame size	Height <sup>1)</sup>				Width <sup>2)</sup>		Depth <sup>3)</sup>				Weight	
	IP22/42		IP54				IP22/42		IP54			
	mm	in.	mm	in.	mm	in.	mm	in.	mm	in.	kg	lb
Standard cabinet												
R8	2145	84.45	2315	91.14	430	16.93	685	26.97	702	27.64	320	705
R11	2145	84.45	2315	91.14	1230	48.43	710	27.95	710	27.95	750	1653

3AXD10000425795

- For marine construction (option +C121) extra height is 10 mm (0.39 in.) due to the attaching bars at the bottom of the cabinet.
- Extra width with brake chopper (option +D150): 400 mm (15.75 in.).  
Extra width with brake resistors (option +D151): SAFURxxxFxxx 400 mm (15.75 in.), 2×SAFURxxxFxxx 800 mm (19.68 in.). Extra width with EMC filter (option +E202): 200 mm (7.87 in.) for frame R8 and 400 mm (15.75 in.) for frame R11.
- For drives with marine attaching bars (option +C121): Depth is 757 mm (29.80 in.).

### ■ Dimensions and weights of sine filter cabinet (option +E206)

Frame size	Height				Width		Depth		Weight	
	IP22/42		IP54							
	mm	in.	mm	in.	mm	in.	mm	in.	kg	lb
<b><math>U_N = 400\text{ V}</math></b>										
0105A-3	2145	84.45	2315	91.14	600	23.62	646	25.43	330	728
0145A-3	2145	84.45	2315	91.14	600	23.62	646	25.43	330	728
0169A-3	2145	84.45	2315	91.14	600	23.62	646	25.43	330	728
0206A-3	2145	84.45	2315	91.14	600	23.62	646	25.43	330	728
0293A-3	2145	84.45	2315	91.14	600	23.62	646	25.43	430	948
0363A-3	2145	84.45	2315	91.14	600	23.62	646	25.43	430	948
0442A-3	2145	84.45	2315	91.14	600	23.62	646	25.43	430	948
0505A-3	2145	84.45	2315	91.14	1000	39.37	646	25.43	840	1852
0585A-3	2145	84.45	2315	91.14	1000	39.37	646	25.43	840	1852
0650A-3	2145	84.45	2315	91.14	1000	39.37	646	25.43	840	1852
<b><math>U_N = 500\text{ V}</math></b>										
0101A-5	2145	84.45	2315	91.14	600	23.62	646	25.43	330	728
0124A-5	2145	84.45	2315	91.14	600	23.62	646	25.43	330	728
0156A-5	2145	84.45	2315	91.14	600	23.62	646	25.43	330	728
0180A-5	2145	84.45	2315	91.14	600	23.62	646	25.43	330	728
0260A-5	2145	84.45	2315	91.14	600	23.62	646	25.43	340	750
0302A-5 <sup>1)</sup>	2145	84.45	2315	91.14	600	23.62	646	25.43	340	750
0361A-5	2145	84.45	2315	91.14	600	23.62	646	25.43	430	948
0414A-5	2145	84.45	2315	91.14	600	23.62	646	25.43	430	948
0460A-5	2145	84.45	2315	91.14	1000	39.37	646	25.43	840	1852
0503A-5	2145	84.45	2315	91.14	1000	39.37	646	25.43	840	1852
<b><math>U_N = 690\text{ V}</math></b>										
0174A-7	2145	84.45	2315	91.14	600	23.62	646	25.43	410	904
0210A-7	2145	84.45	2315	91.14	600	23.62	646	25.43	410	904
0271A-7	2145	84.45	2315	91.14	600	23.62	646	25.43	410	904

Frame size	Height				Width		Depth		Weight	
	IP22/42		IP54		mm	in.	mm	in.	kg	lb
	mm	in.	mm	in.						
0330A-7	2145	84.45	2315	91.14	400	15.75	646	25.43	340	750
0370A-7	2145	84.45	2315	91.14	400	15.75	646	25.43	340	750
0430A-7	2145	84.45	2315	91.14	400	15.75	646	25.43	340	750

3AXD10000425795

1) US type

## Free space requirements

Front		Side		Above*	
mm	in.	mm	in.	mm	in.
150	5.91	-	-	400	15.75

\* Measured from the base plate of the cabinet top.

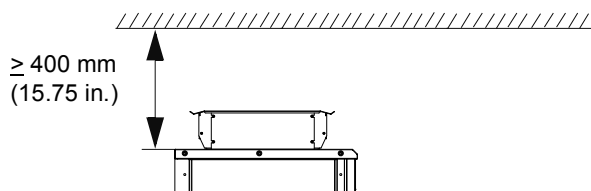

Door opening:

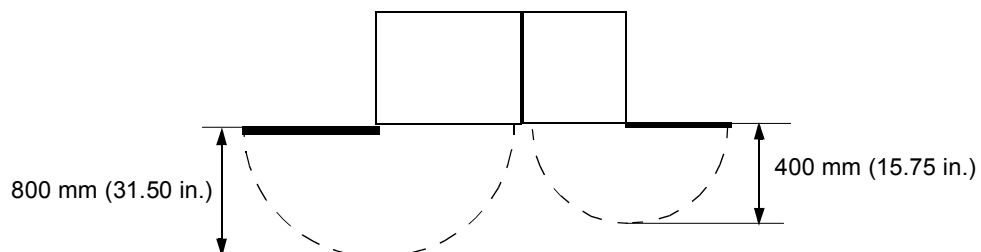

## Cooling data, noise

This table shows typical heat dissipation values, required air flow and noise at the nominal ratings of the drive. The heat loss values can vary depending on product configuration, voltage, cable conditions, motor efficiency and power factor. To obtain more accurate values for given conditions, use ABB DriveSize tool (<http://new.abb.com/drives/softwaretools/drivesize>).

Drive type ACS880-37-	Air flow <sup>3)</sup>				Heat dissipation		Noise	
	-		+E206		-	+E206 <sup>1)</sup>	-	+E206 <sup>2)</sup>
	m <sup>3</sup> /h	ft <sup>3</sup> /min	m <sup>3</sup> /h	ft <sup>3</sup> /min	kW	kW	dB(A)	dB(A)
<b>U<sub>N</sub> = 400 V</b>								
0105A-3	700	412	*	*	2.22	0.6	70	70
0145A-3	700	412	*	*	3.33	0.55	70	70
0169A-3	700	412	*	*	3.57	0.55	70	70
0206A-3	805	474	*	*	4.44	0.9	70	70
0293A-3	2100	1279	*	*	6.88	1.57	77	77
0363A-3	2100	1279	*	*	8.52	1.57	77	77
0442A-3	2100	1279	*	*	10.52	1.7	77	77
0505A-3	2100	1279	2000	1177	10.54	3.0	77	80
0585A-3	2100	1279	2000	1177	13.16	3.4	77	80
0650A-3	2100	1279	2000	1177	14.78	3.8	77	80
<b>U<sub>N</sub> = 500 V</b>								
0101A-5	700	412	*	*	2.32	0.63	70	70
0124A-5	700	412	*	*	3.14	0.63	70	70
0156A-5	700	412	*	*	3.54	0.55	70	70
0180A-5	805	474	*	*	4.27	0.55	70	70
0260A-5	2100	1279	*	*	6.86	0.9	77	77
0302A-5	2100	1279	-	-	-	-	77	77
0361A-5	2100	1279	*	*	8.50	1.57	77	77
0414A-5	2100	1279	*	*	10.51	1.57	77	77
0460A-5	2100	1279	2000	1177	13.15	3.3	77	80
0503A-5	2100	1279	2000	1177	14.76	3.6	77	80
<b>U<sub>N</sub> = 690 V</b>								
0174A-7	2100	1279	*	*	6.86	0.93	77	77
0210A-7	2100	1279	*	*	8.46	0.93	77	77
0271A-7	2100	1279	*	*	10.49	0.93	77	77
0330A-7	2100	1279	700	412	13.09	2.2	77	80
0370A-7	2100	1279	700	412	14.71	2.3	77	80
0430A-7	2100	1279	700	412	16.53	2.4	77	80

3AXD10000425795

<sup>1)</sup> Additional heat dissipation of sine filter (option +E206)

<sup>2)</sup> Noise of the drive + sine filter (option +E206)

<sup>3)</sup> Air flow for the 400 mm (15.75 in) wide brake resistor (option +D151) cubicle: 525 m<sup>3</sup>/h (309 ft<sup>3</sup>/min). Air flow for the 800 mm (31.50 in) wide brake resistor cubicle: 2210 m<sup>3</sup>/h (1300 ft<sup>3</sup>/min).

\* Natural convection

## Sine output filter data

Sine output filters are available as option +E206. The table below shows the types and technical data of the filters and filter cubicles used in the drive.

Drive type ACS880-37-	Sine filter(s) used		$I_N$ A	Cooling data	
	Qty	Type		Heat dissipation kW	Air flow m <sup>3</sup> /h (ft <sup>3</sup> /min)
<b><math>U_N = 400\text{ V}</math></b>					
0105A-3	1	B84143V0130R230	91	0.63	*
0145A-3	1	B84143V0162R229	126	0.55	*
0169A-3	1	B84143V0162R229	153	0.55	*
0206A-3	1	B84143V0230R229	187	0.90	*
0293A-3	1	B84143V0390R229	264	1.57	*
0363A-3	1	B84143V0390R229	327	1.57	*
0442A-3	1	B84143V0390R229	398	1.57	*
0505A-3	1	NSIN0900-6	455	2.89	2000 (1177)
0585A-3	1	NSIN0900-6	527	3.35	2000 (1177)
0650A-3	1	NSIN0900-6	585	3.73	2000 (1177)
<b><math>U_N = 500\text{ V}</math></b>					
0101A-5	1	B84143V0130R230	80	0.63	*
0124A-5	1	B84143V0130R230	104	0.63	*
0156A-5	1	B84143V0162R229	140	0.55	*
0180A-5	1	B84143V0162R229	162	0.55	*
0260A-5	1	B84143V0230R229	234	0.90	*
0302A-5 <sup>1)</sup>	1	B84143V0390R229	272	1.57	*
0361A-5	1	B84143V0390R229	325	1.57	*
0414A-5	1	B84143V0390R229	373	1.57	*
0460A-5	1	NSIN0900-6	414	3.16	2000 (1177)
0503A-5	1	NSIN0900-6	453	3.46	2000 (1177)
<b><math>U_N = 690\text{ V}</math></b>					
0174A-7	1	B84143V0207R230	157	0.93	*
0210A-7	1	B84143V0207R230	189	0.93	*
0271A-7	1	B84143V0207R230	244	0.93	*
0330A-7	1	NSIN0485-6	297	2.0	700 (412)
0370A-7	1	NSIN0485-6	333	2.2	700 (412)
0430A-7	1	NSIN0485-6	387	2.6	700 (412)

3AXD10000425795

<sup>1)</sup>	USA only
*	Natural convection
$I_N$	Continuous rms output current. No overload capability at 40 °C (104 °F)

## Terminal and exit data for the power cables

The locations and sizes of exits are shown in the dimension drawings delivered with the drive, and in the dimension drawing examples starting on page [243](#).

The location and size of power cable terminals are shown in the drawings starting on page [257](#).

### ■ IEC

Frame size	Number of holes in the entry plate for the power cables. Hole diameter 60 mm.	Terminals L1, L2, L3, U2, V2, W2, UDC+/R+, UDC- and R-			Grounding terminals	
		Max. phase conductor size mm <sup>2</sup>	Bolt size	Tightening torque	Bolt size	Tightening torque N·m
R8	6...12	185	M10	20...40 N·m	M12	50...75 N·m
R11	12	3×240 or 4×185	M12	50...75 N·m	M12	50...75 N·m

### US

Frame size	Terminals L1, L2, L3, U2, V2, W2, UDC+/R+, UDC- and R-			Grounding terminals	
	Max. phase conductor size AWG/kcmil	Busbar bolt size – Hole spacing	Tightening torque bf·ft	Bolt size	Tightening torque bf·ft
R8	350 MCM...1×500 MCM or 4×350 MCM	M12 7/16" × 1 – 1.75"	15...30	M10 (3/8")	37...55
R11	1×500 MCM or 4×350 MCM	M12 (7/16") × 3 – 1.75"	37...55	M10 (3/8")	37...55

## Terminal data for the drive control unit

See chapter [Control unit of frame R11](#) (page [151](#)).

## Electrical power network specification

<b>Voltage (<math>U_1</math>)</b>	<p><u>ACS880-37-xxxx-3 drives:</u> 380...415 VAC 3-phase +10%...-15%. This is indicated in the type designation label as typical input voltage level. 3 ~ 400 V AC.</p> <p><u>ACS880-37-xxxx-5 drives:</u> 380...500 VAC 3-phase +10%...-15%. This is indicated in the type designation label as typical input voltage levels. 3 ~ 400/480/500 V AC.</p> <p><u>ACS880-37-xxxx-7 drives:</u> 525...690 VAC 3-phase +10%...-15%. This is indicated in the type designation label as typical input voltage levels. 3 ~ 525/600/690 V AC.</p>
<b>Network type</b>	TN (grounded) and IT (ungrounded) systems
<b>Frequency (<math>f_1</math>)</b>	50/60 Hz, Variation $\pm 5\%$ of nominal frequency
<b>Imbalance</b>	Max. $\pm 3\%$ of nominal phase-to-phase voltage
<b>Short-circuit withstand strength (IEC 61439-1)</b>	<p>Maximum allowable prospective short-circuit current is 65 kA when the input cable is protected with gG type fuses (IEC 60269) having maximum operating time of 0.1 seconds and maximum current rating as follows:</p> <ul style="list-style-type: none"> <li>• 400 A for frame R8</li> <li>• 1250 A for frame R11.</li> </ul>
<b>Short-circuit current protection (UL 508C)</b>	The drive is suitable for use on a circuit capable of delivering not more than 100,000 rms symmetrical amperes at 600 V maximum when the input cable is protected with class T fuses.
<b>Short-circuit current protection (CSA C22.2 No. 14-13)</b>	The drive is suitable for use on a circuit capable of delivering not more than 100,000 rms symmetrical amperes at 600 V maximum when the input cable is protected with T class fuses.
<b>Power factor</b>	$\cos \phi_1 = 1$ , $\cos \phi$ (total) = 0.99
<b>Harmonic distortion</b>	<p>THD (Total harmonic distortion) current <math>&lt; 0.05 \cdot I_{1\text{cont.max}}</math> if supply network voltage is not distorted by other loads and when the drive operates at the nominal load.</p> <p><math>I_{1\text{cont.max}}</math> is continuous maximum input current of the line-side converter.</p> <p>The table below shows typical results on indicated networks. The values are measured at the drive's input terminals.</p>

$R_{sc}$	THD Voltage [%]	THD Current [%]
20	3	2.5*
100	1.9	2.5*

Harmonics are below the limits defined in IEEE519, IEC61000-3-12 and G5/4 standards.

$$\sqrt{\sum_{n=2}^{50} \left(\frac{I_n}{I_N}\right)^2}$$

$I_n$   $n^{\text{th}}$  harmonic component  
 $I_N$  nominal current

**THD** Total Harmonic Distortion (THD). The voltage THD depends on the short-circuit ratio ( $R_{sc}$ ). The spectrum of the distortion also contains interharmonics.

$$R_{sc} = I_{sc}/I_N$$

$I_{sc}$  short-circuit current at point of common coupling (PCC)

$I_N$  drive nominal current

\* Other loads can influence the THD value.

## Motor connection data

<b>Motor types</b>	Asynchronous AC induction motors, permanent magnet synchronous motors, AC induction servomotors, ABB synchronous reluctance (SynRM) motors
<b>Voltage (<math>U_2</math>)</b>	0 to $U_1$ , 3-phase symmetrical, This is indicated in the type designation label as typical output voltage level as $3 \sim 0 \dots U_1$ , $U_{\max}$ at the field weakening point.
<b>Frequency (<math>f_2</math>)</b>	0...±500 Hz. Operation above 120 Hz can require type-specific derating, see section <a href="#">High speed mode</a> (page 223). For drives with sine filter (option +E206): 120 Hz. For drives with du/dt filter (option +E205): 120 Hz.
<b>Current</b>	See section <a href="#">Ratings</a> .
<b>Switching frequency</b>	3 kHz (typically)
<b>Maximum recommended motor cable length</b>	500 m (1640 ft). <b>Note:</b> Longer cables cause a motor voltage decrease which limits the available motor power. The decrease depends on the motor cable length and characteristics. Contact ABB for more information. Note that a sine filter (optional) at the drive output also causes a voltage decrease. <b>Note:</b> With motor cables longer than 100 m (328 ft) the EMC Directive requirements may not be fulfilled.

## Control unit connection data

See chapter [Control unit of frame R11](#) (page 151).

## Efficiency

97% at nominal power level

## Protection classes

<b>Degrees of protection (IEC/EN 60529)</b>	IP22 (standard), IP42 (option +B054), IP54 (option +B055)
<b>Enclosure types (UL 61800-5-1)</b>	UL Type 1 (standard), UL Type 1 Filtered (option +B054), UL Type 12 (option +B055). For indoor use only
<b>Overvoltage category (IEC 60664-1)</b>	III
<b>Protective class (IEC/EN 61800-5-1)</b>	I

## Ambient conditions

Environmental limits for the drive system are given below. The drive is to be used in a heated, indoor, controlled environment.

	<b>Operation</b> installed for stationary use	<b>Storage</b> in the protective package	<b>Transportation</b> in the protective package
<b>Installation site altitude</b>	0 to 2000 m (6561 ft) above sea level. For altitudes over 2000 m, contact ABB. Output derated above 1000 m (3281 ft). See section <a href="#">Derating</a> .	-	-



<b>Air temperature</b>	0 ... +40 °C (+32 ... +104 °F). No condensation allowed. Output derated in the range +40 ... +50 °C (+104 ... +122 °F). See section <a href="#">Derating</a> .	-40 to +70 °C (-40 to +158 °F)	-40 to +70 °C (-40 to +158 °F)
<b>Relative humidity</b>	Max. 95%	Max. 95%	Max. 95%
	No condensation allowed. Maximum allowed relative humidity is 60% in the presence of corrosive gases.		
<b>Contamination</b>	IEC/EN 60721-3-3:2002: Classification of environmental conditions - Part 3-3: Classification of groups of environmental parameters and their severities - Stationary use of weather protected locations	IEC 60721-3-1	IEC 60721-3-2
Chemical gases	Class 3C2	Class 1C2	Class 2C2
Solid particles	Class 3S2 (3S1 with IP20). No conductive dust allowed.	Class 1S3 (packing must support this, otherwise 1S2)	Class 2S2
<b>Pollution degree</b> (IEC/EN 61800-5-1)	Pollution degree 2	-	-
<b>Vibration</b>	IEC 61800-5-1 IEC 60068-2-6:2007, EN 60068-2-6:2008 Environmental testing Part 2: Tests –Test Fc: Vibration (sinusoidal) 10...57 Hz: max. 0.075 mm amplitude 57... 150 Hz: 1 g	IEC 60721-3-1:2018 Part 3-1: Class 1M12	IEC 60721-3-2:2018 Part 3-2: Class 2M4
<b>Shock</b> IEC 60068-2-27:2008, EN 60068-2-27:2009 Environmental testing - Part 2-27: Tests - Test Ea and guidance: Shock	Not allowed	With packing max. 100 m/s <sup>2</sup> (330 ft./s <sup>2</sup> ) 11 ms	With packing max. 100 m/s <sup>2</sup> (330 ft./s <sup>2</sup> ) 11 ms

## Auxiliary circuit power consumption

<b>Cabinet heater and lighting (options +G300 and +G301)</b>	150 W
<b>External uninterruptible power supply (option +G307)</b>	150 W
<b>Motor heater (option +G313)</b>	According to heater type

## Materials

**Cabinet** Hot-dip zinc coated 1.5 mm thick steel sheet (thickness of coating approximately 100...200 micrometers). Polyester thermosetting powder coating (thickness approximately 80 micrometers) on visible surfaces, color RAL 7035 and RAL 9017.

Plastic parts are made of UV resistant f1 classified plastics.

**Busbars**

Tin-plated copper

**Air filters of IP54 units**

Inlet (door)	Outlet (roof)
Camfil/airComp 300-50 288 mm x 521 mm 688 mm x 521 mm	Camfil/airTex G150 2 pcs: 398 mm x 312 mm

**Fire safety of materials**  
(IEC 60332-1)

Insulating materials and non-metallic items mostly self-extinctive

**Package**

Standard package:

- timber, polyethylene sheet (thickness 0.15 mm), stretch film (thickness 0.023 mm), PP tape, PET strap, sheet metal (steel)
- for land and air transport when planned storage time is less than 2 months or when storage can be arranged in clean and dry conditions less than 6 months
- can be used when products will not be exposed to corrosive atmosphere during transport or storage

Container package:

- timber, VCI sheet film (PE, thickness 0.10 mm), VCI stretch film (PE, thickness 0.04 mm), VCI emitter bags, PP tape, PET strap, sheet metal (steel)
- for sea transport in containers
- recommended for land and air transport when storage time prior to installation exceeds 6 months or storage is arranged in partially weather-protected conditions

Seaworthy package:

- timber, plywood, VCI sheet film (PE, thickness 0.15 mm), VCI stretch film (PE, thickness 0.04 mm), VCI emitter bags, PP tape, PET strap, sheet metal (steel)
- for sea transport with or without containerization
- for long storage periods in environments where roofed and humidity-controlled storage cannot be arranged

Cabinets are attached to the pallet with screws and braced from the top end to the package walls to prevent swaying inside the package. Package elements are attached together with screws. For handling the packages, see section [Moving and unpacking the drive](#) on page 69.

**Disposal**

The main parts of the drive can be recycled to preserve natural resources and energy. Product parts and materials should be dismantled and separated.

Generally all metals, such as steel, aluminum, copper and its alloys, and precious metals can be recycled as material. Plastics, rubber, cardboard and other packaging material can be used in energy recovery. Printed circuit boards and large electrolytic capacitors need selective treatment according to IEC 62635 guidelines. To aid recycling, plastic parts are marked with an appropriate identification code.

Contact your local ABB distributor for further information on environmental aspects and recycling instructions for professional recyclers. End of life treatment must follow international and local regulations.

## Applicable standards

The drive complies with the standards below. The compliance with the European Low Voltage Directive is verified according to standard EN 61800-5-1.

### European electrical safety requirements product standards

<b>EN 61800-5-1:2007</b>	<i>Adjustable speed electrical power drive systems. Part 5-1: Safety requirements – electrical, thermal and energy</i>
<b>IEC 60146-1-1:2009</b>	<i>Semiconductor converters – General requirements and line commutated converters – Part 1-1: Specification of basic requirements</i>
<b>EN 60146-1-1:2010</b>	
<b>IEC 60204-1:2005 +A1:2008</b>	<i>Safety of machinery. Electrical equipment of machines. Part 1: General requirements.</i>
<b>EN 60204-1:2006 +AC:2010</b>	Provisions for compliance: The final assembler of the machine is responsible for installing emergency-stop device.
<b>IEC 60529:1989</b>	<i>Degrees of protection provided by enclosures (IP code)</i>
<b>EN 60529:1991</b>	
<b>IEC/EN 60664-1:2007</b>	<i>Insulation coordination for equipment within low-voltage systems. Part 1: Principles, requirements and tests</i>
<b>IEC/EN 61439-1:2011</b>	<i>Low-voltage switchgear and control gear assemblies -- Part 1: General rules</i>
<b>UL 50:2015</b>	<i>Enclosures for Electrical Equipment, Non-Environmental Considerations, 13th edition</i>
<b>UL 508A: 2016</b>	<i>UL Standard for Safety, Power Conversion</i>
<b>UL 508A: 2013</b>	<i>UL Standard for Industrial Control Panels, second edition</i>

### EMC performance

<b>IEC 61800-3:2004/A1:2011</b>	<i>Adjustable speed electrical power drive systems. Part 3: EMC requirements and specific test methods</i>
<b>EN 61800-3/A1:2012</b>	

## CE marking

A CE mark is attached to the drive to verify that the drive complies with the provisions of the European Low Voltage and EMC Directives. The CE marking also verifies that the drive, in regard to its safety functions (such as Safe torque off), conforms with the Machinery Directive as a safety component.

### ■ Compliance with the European Low Voltage Directive

The compliance with the European Low Voltage Directive has been verified according to standard EN 61800-5-1.

### ■ Compliance with the European EMC Directive

The EMC Directive defines the requirements for immunity and emissions of electrical equipment used within the European Union. The EMC product standard (EN 61800-3:2004) covers requirements stated for drives. See section [Compliance with EN 61800-3:2004 + A1:2012](#) below.

### ■ Compliance with the European Machinery Directive

The drive is an electronic product which is covered by the European Low Voltage Directive. However, the drive includes the Safe torque off function and can be equipped with other safety functions for machinery which, as safety components, are in the scope of the Machinery Directive. These functions of the drive comply with European harmonized standards such as EN 61800-5-2. The declaration of conformity is shown below.

## EU Declaration of Conformity



# EU Declaration of Conformity

Machinery Directive 2006/42/EC

We

Manufacturer: ABB Oy

Address: Hiomotie 13, 00380 Helsinki, Finland.

Phone: +358 10 22 11

declare under our sole responsibility that the following products:

**Frequency converters and frequency converter components**

**ACS880-04, -14, -34** (frames nxR8i)

**ACS880-04XT**

**ACS880-07, -17, -37**

**ACS880-104**

**ACS880 multidrives**

**ACS880-104LC** (frames nxR8i)

**ACS880-07CLC**

identified with serial numbers beginning with 1 or 8

with regard to the safety functions

**Safe torque off**

**Safe motor temperature** with FPTC-01 module (option code +L536)

**Safe stop 1, Safe stop emergency, Safely-limited speed, Safe maximum speed, Safe brake control, Prevention of unexpected start-up**, with FSO-12 module (option code +Q973)

**Safe stop 1, Safe stop emergency, Safely-limited speed, Safe maximum speed, Safe brake control, Safe Speed monitor, Safe direction, Prevention of unexpected start-up**, with FSO-21 and FSE-31 modules (option codes +Q972 and +L521)

**ACS880-07, -17, -37, -07CLC and ACS880 multidrives: Prevention of unexpected start-up** (option codes +Q950; +Q957), **Emergency stop** (option codes +Q951; +Q952; +Q963; +Q964; +Q978; +Q979), **Safely-limited speed** (option codes +Q965; Q966)

are in conformity with all the relevant safety component requirements of EU Machinery Directive 2006/42/EC, when the listed safety functions are used for safety component functionality.



The following harmonized standards have been applied:

EN 61800-5-2:2007	Adjustable speed electrical power drive systems – Part 5-2: Safety requirements - Functional
EN 62061:2005 + AC:2010 + A1:2013 + A2:2015	Safety of machinery – Functional safety of safety-related electrical, electronic and programmable electronic control systems
EN ISO 13849-1:2015	Safety of machinery – Safety-related parts of control systems. Part 1: General principles for design
EN ISO 13849-2:2012	Safety of machinery – Safety-related parts of the control systems. Part 2: Validation
EN 60204-1:2006 + A1:2009 + AC:2010	Safety of machinery – Electrical equipment of machines – Part 1: General requirements

The following other standard has been applied:

IEC 61508:2010, parts 1-2	Functional safety of electrical / electronic / programmable electronic safety-related systems
IEC 61800-5-2:2016	Adjustable speed electrical power drive systems – Part 5-2: Safety requirements - Functional

The products referred in this Declaration of conformity fulfil the relevant provisions of other European Union Directives which are notified in Single EU Declaration of conformity 3AXD10000497305.

Person authorized to compile the technical file:

Name and address: Vesa Tiihonen, Hiomotie 13, 00380 Helsinki, Finland

Helsinki, 09 May 2018

Manufacturer representative:



Peter Lindgren  
Vice President, ABB Oy

## Compliance with EN 61800-3:2004 + A1:2012

### ■ Definitions

EMC stands for **E**lectromagnetic **C**ompatibility. It is the ability of electrical/electronic equipment to operate without problems within an electromagnetic environment. Likewise, the equipment must not disturb or interfere with any other product or system within its locality.

*First environment* includes establishments connected to a low-voltage network which supplies buildings used for domestic purposes.

*Second environment* includes establishments connected to a network not supplying domestic premises.

*Drive of category C2:* drive of rated voltage less than 1000 V and intended to be installed and started up only by a professional when used in the first environment. **Note:** A professional is a person or organization having necessary skills in installing and/or starting up power drive systems, including their EMC aspects.

*Drive of category C3:* drive of rated voltage less than 1000 V and intended for use in the second environment and not intended for use in the first environment.

*Drive of category C4:* drive of rated voltage equal to or above 1000 V, or rated current equal to or above 400 A, or intended for use in complex systems in the second environment.

### ■ Category C2

The drive complies with the standard with the following provisions:

1. The drive is equipped with EMC filter option +E202.
2. The motor and control cables are selected as specified in the hardware manual.
3. The drive is installed according to the instructions given in the hardware manual.
4. Maximum motor cable length is 100 meters (328 ft).

---

**WARNING!** The drive may cause radio interference if used in a residential or domestic environment. The user is required to take measures to prevent interference, in addition to the requirements for CE compliance listed above, if necessary.

---

**Note:** Do not install a drive equipped with EMC filter +E202 on IT (ungrounded) systems. The supply network becomes connected to ground potential through the EMC filter capacitors which may cause danger or damage the unit.

### ■ Category C3

The drive complies with the standard with the following provisions:

1. Frame R8: The drive is equipped with EMC filter option +E200 or +E201.
2. The motor and control cables are selected as specified in the hardware manual.
3. The drive is installed according to the instructions given in the hardware manual.
4. Maximum motor cable length is 100 meters (328 ft).

---

**WARNING!** A drive of category C3 is not intended to be used on a low-voltage public network which supplies domestic premises. Radio frequency interference is expected if

---

the drive is used on such a network.

### ■ Category C4

If the provisions under [Category C3](#) cannot be met, the requirements of the standard can be met as follows:

1. It is ensured that no excessive emission is propagated to neighboring low-voltage networks. In some cases, the natural suppression in transformers and cables is sufficient. If in doubt, the supply transformer with static screening between the primary and secondary windings can be used.

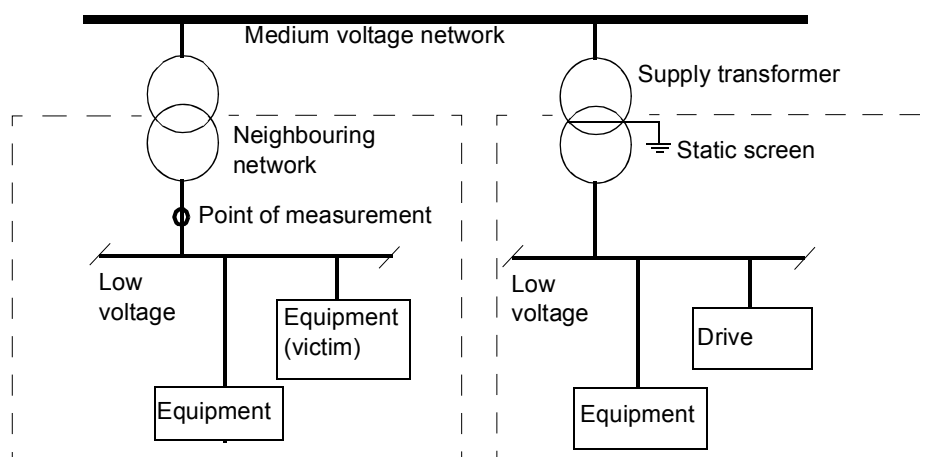

2. An EMC plan for preventing disturbances is drawn up for the installation. A template is available from the local ABB representative.
3. The motor and control cables are selected as specified in the hardware manual.
4. The drive is installed according to the instructions given in the hardware manual.

**WARNING!** A drive of category C4 is not intended to be used on a low-voltage public network which supplies domestic premises. Radio frequency interference is expected if the drive is used on such a network.

## UL marking

The drive is UL approved. The approval is valid with rated voltages.

### ■ UL checklist



**WARNING!** Operation of this drive requires detailed installation and operation instructions provided in the hardware and software manuals. The manuals are provided in electric format in the drive package or on the Internet. Retain the manuals with the drive at all times. Hard copies of the manuals can be ordered through the manufacturer.

- Make sure that the drive type designation label includes the cULus Listed marking.
- **CAUTION - Risk of electric shock.** After disconnecting the input power, always wait for 5 minutes to let the intermediate circuit capacitors discharge before you start working on the drive, motor or motor cable.
- The drive is to be used in a heated, indoor controlled environment. The drive must be installed in clean air according to enclosure classification. Cooling air must be clean, free from corrosive materials and electrically conductive dust.
- The maximum surrounding air temperature is 40 °C (104 °F) at rated current. The current is derated for 40 to 50 °C (104 to 122 °F).
- The drive is suitable for use in a circuit capable of delivering not more than 100,000 rms symmetrical amperes, 600 V maximum when the input cable is protected with fuses given on page 231. The ampere rating is based on tests done according to the appropriate UL standard.

If the short-circuit tests are done with other fuses than the ones given in the UL fuse table of the manual, give those fuses. See sections *Electrical power network specification / Short-circuit current protection (ANSI/UL 61800-5-1:2015)* and *Short-circuit current protection (CSA C22.2 No 14-13)*.

- The cables located within the motor circuit must be rated for at least 75 °C (167 °F) in UL-compliant installations.
- The input cable must be protected with fuses. These fuses provide branch circuit protection in accordance with the National Electrical Code (NEC) and Canadian Electrical Code. For installation in the United States, also obey any other applicable local codes. For installation in Canada, also obey any applicable provincial codes.

**Note:** Circuit breakers must not be used without fuses in the USA. For suitable circuit breakers, contact your local ABB representative.



**WARNING!** The opening of the branch-circuit protective device may be an indication that a fault current has been interrupted. To reduce the risk of fire or electric shock, current-carrying parts and other components of the controller should be examined and replaced if damaged.

- The drive is equipped with UL classified fuses which provide branch circuit protection in accordance with the National Electrical Code (NEC) and Canadian Electrical Code. The fuses are listed on page 225.
- The drive provides motor overload protection. For adjustments, see the firmware manual.
- For drive overvoltage category, see page 232. For pollution degree, see page 232.

## CSA marking

The drives are CSA marked. The approval is valid with rated voltages.



## RCM marking

RCM marking is required in Australia and New Zealand. An RCM mark is attached to the drive modules to verify compliance with the relevant standard (IEC 61800-3:2004), mandated by the Trans-Tasman Electromagnetic Compatibility Scheme.

For fulfilling the requirements of the standard, see section [Compliance with EN 61800-3:2004 + A1:2012](#).





## The KC (Korea Certification) marking

Product complies with Korea's product safety requirements for electrical and electronic equipment and components that utilize power from 50...1000 V AC.



## WEEE marking

The drive is marked with the wheelie bin symbol. It indicates that at the end of life the drive should enter the recycling system at an appropriate collection point and not placed in the normal waste stream. See section [Disposal](#) on page [234](#).

## EAC (Eurasian Conformity) marking

The drive has EAC certification. EAC marking is required in Russia, Belarus and Kazakhstan.



## EIP (Electronic Information Products) marking

An EIP mark is attached to the drive to verify that the drive complies with the regulations of the Chinese Administrative Measure on the Control of Pollution Caused by Electronic Information Products.

## Tightening torques

Unless a tightening torque is specified in the text, the following torques can be used.

### ■ Electrical connections

Size	Torque (N·m)	Note
M3	0.5	Strength class 4.6...8.8
M4	1	Strength class 4.6...8.8
M5	4	Strength class 8.8
M6	9	Strength class 8.8
M8	22	Strength class 8.8
M10	42	Strength class 8.8
M12	70	Strength class 8.8
M16	120	Strength class 8.8

### ■ Mechanical connections

Size	Max. torque (N·m)	Note
M5	6	Strength class 8.8
M6	10	Strength class 8.8
M8	24	Strength class 8.8

### ■ Insulation supports

Size	Max. torque (N·m)	Note
M6	5	Strength class 8.8
M8	9	Strength class 8.8
M10	18	Strength class 8.8
M12	31	Strength class 8.8

## ■ Cable lugs

Size	Max. torque (N·m)	Note
M8	15	Strength class 8.8
M10	32	Strength class 8.8
M12	50	Strength class 8.8

## Disclaimers

### ■ Generic disclaimer

The manufacturer shall have no obligation with respect to any product which (i) has been improperly repaired or altered; (ii) has been subjected to misuse, negligence or accident; (iii) has been used in a manner contrary to the manufacturer's instructions; or (iv) has failed as a result of ordinary wear and tear.

### ■ Cybersecurity disclaimer

This product is designed to be connected to and to communicate information and data via a network interface. It is Customer's sole responsibility to provide and continuously ensure a secure connection between the product and Customer network or any other network (as the case may be). Customer shall establish and maintain any appropriate measures (such as but not limited to the installation of firewalls, application of authentication measures, encryption of data, installation of anti-virus programs, etc) to protect the product, the network, its system and the interface against any kind of security breaches, unauthorized access, interference, intrusion, leakage and/or theft of data or information. ABB and its affiliates are not liable for damages and/or losses related to such security breaches, any unauthorized access, interference, intrusion, leakage and/or theft of data or information.

14

# Dimensions

---

## Contents of this chapter

This chapter contains example dimension drawings.

---

# R8: IP22 (UL Type 1), option +B054 (IP42 [UL Type 1 Filtered])

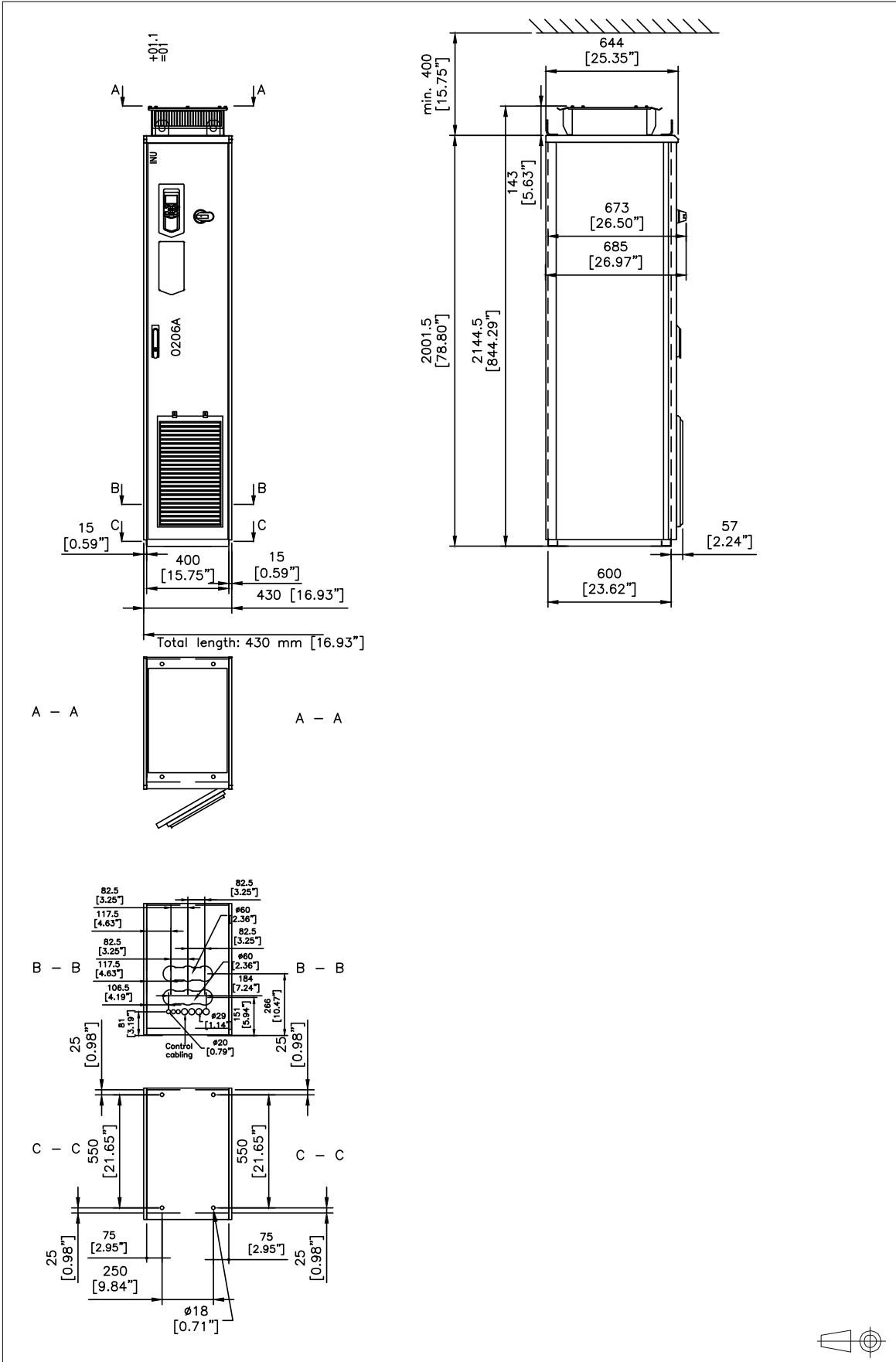

### R8 (IP54, UL Type 12, option +B055): option +C129

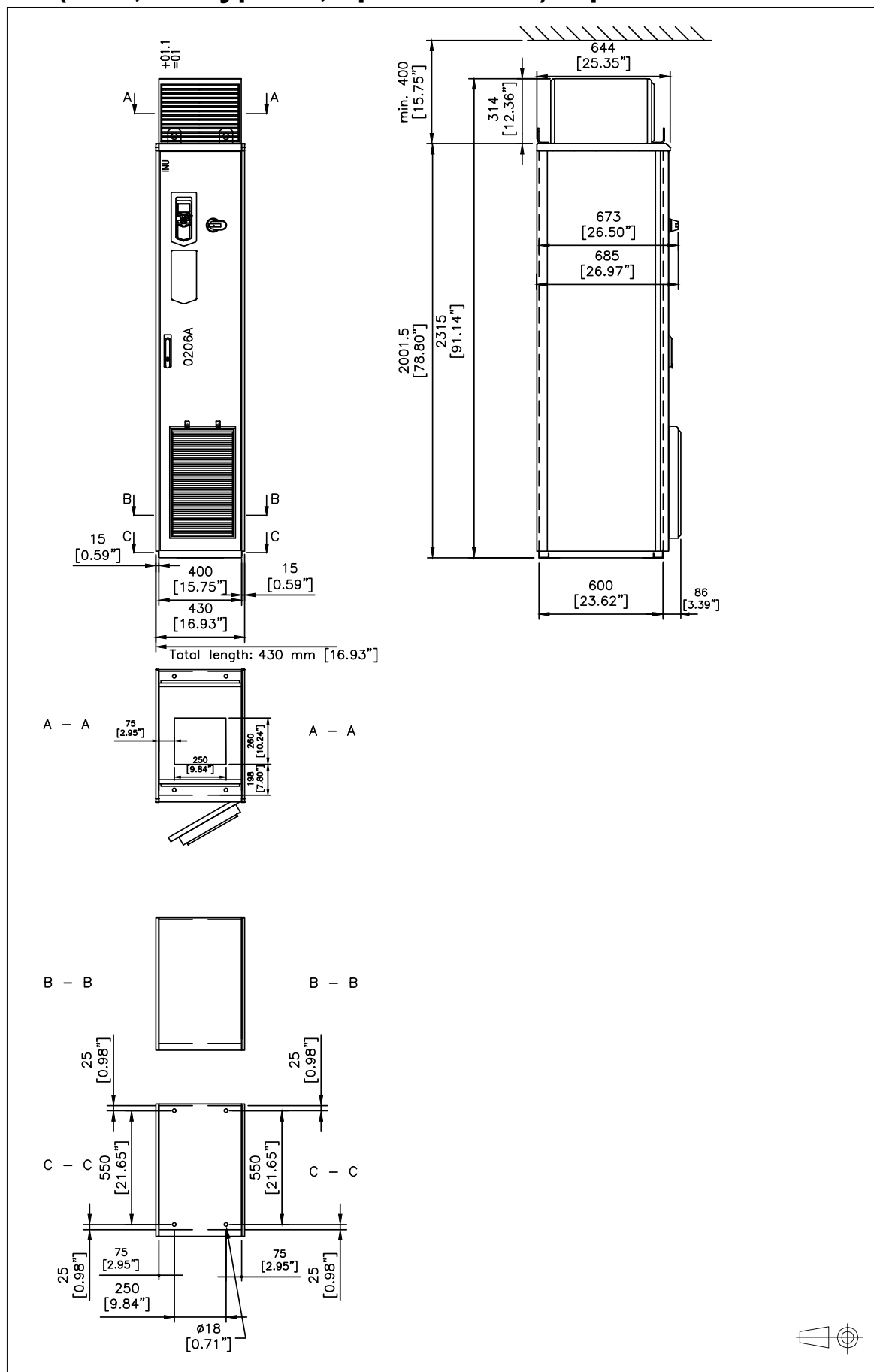

# R8 IP22 (UL Type 1) and IP42 (UL Type 1 Filtered, option +B054): options +D150, +D151

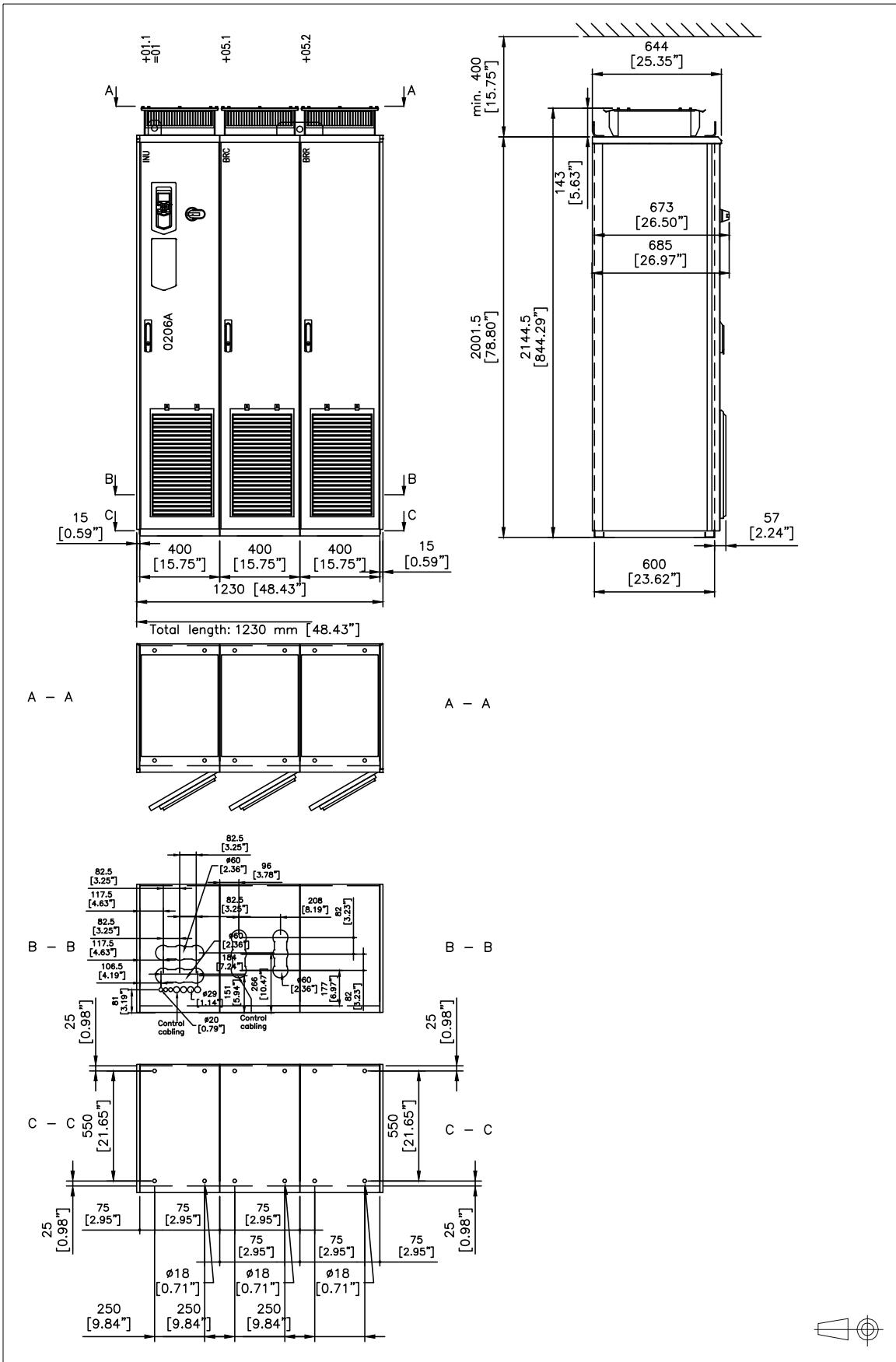



# R11 IP22 (UL Type 1) and IP42 (UL Type 1 Filtered, option +B054)

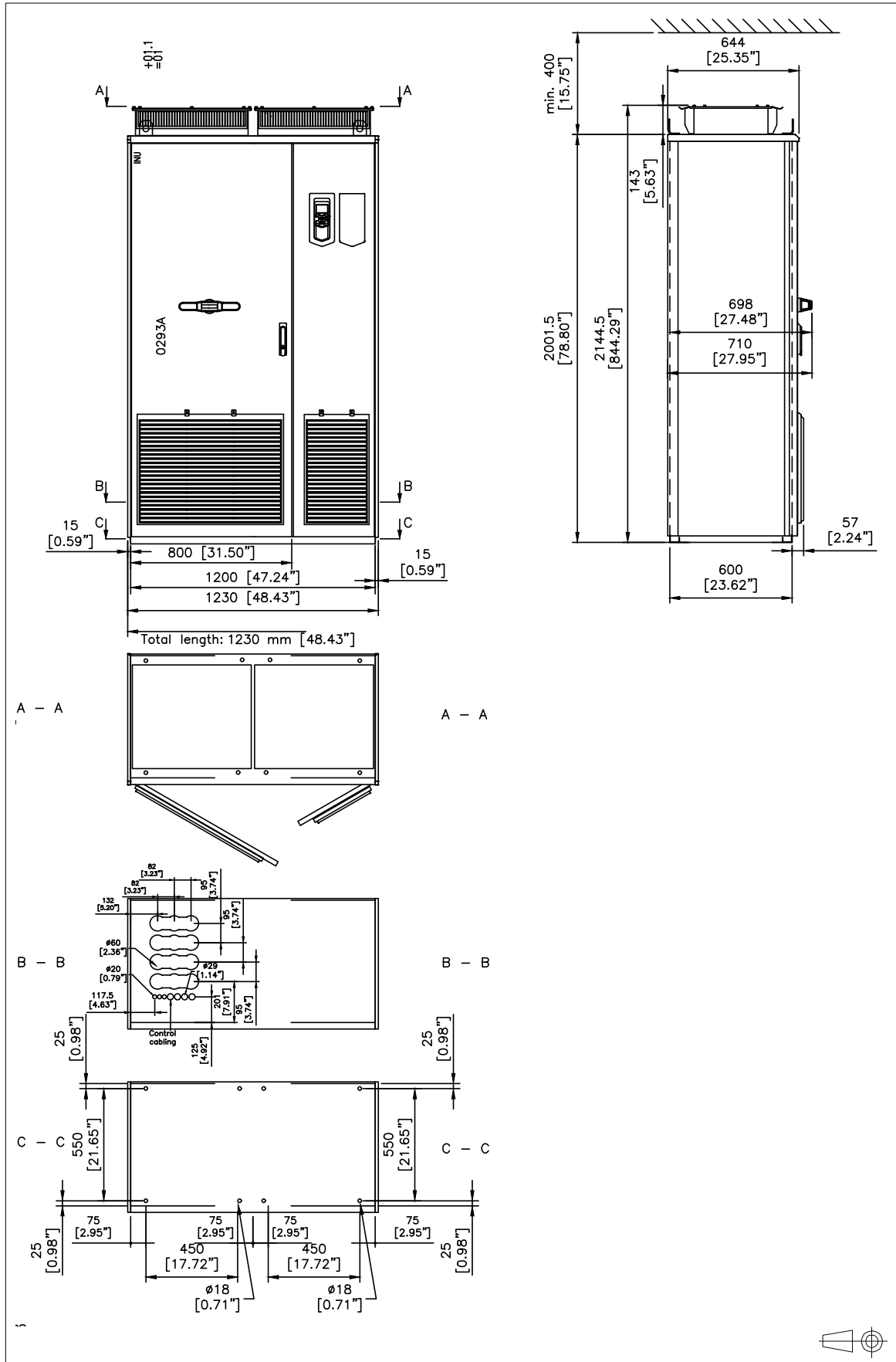



### R11: option+B055 (IP54 [UL Type 12])

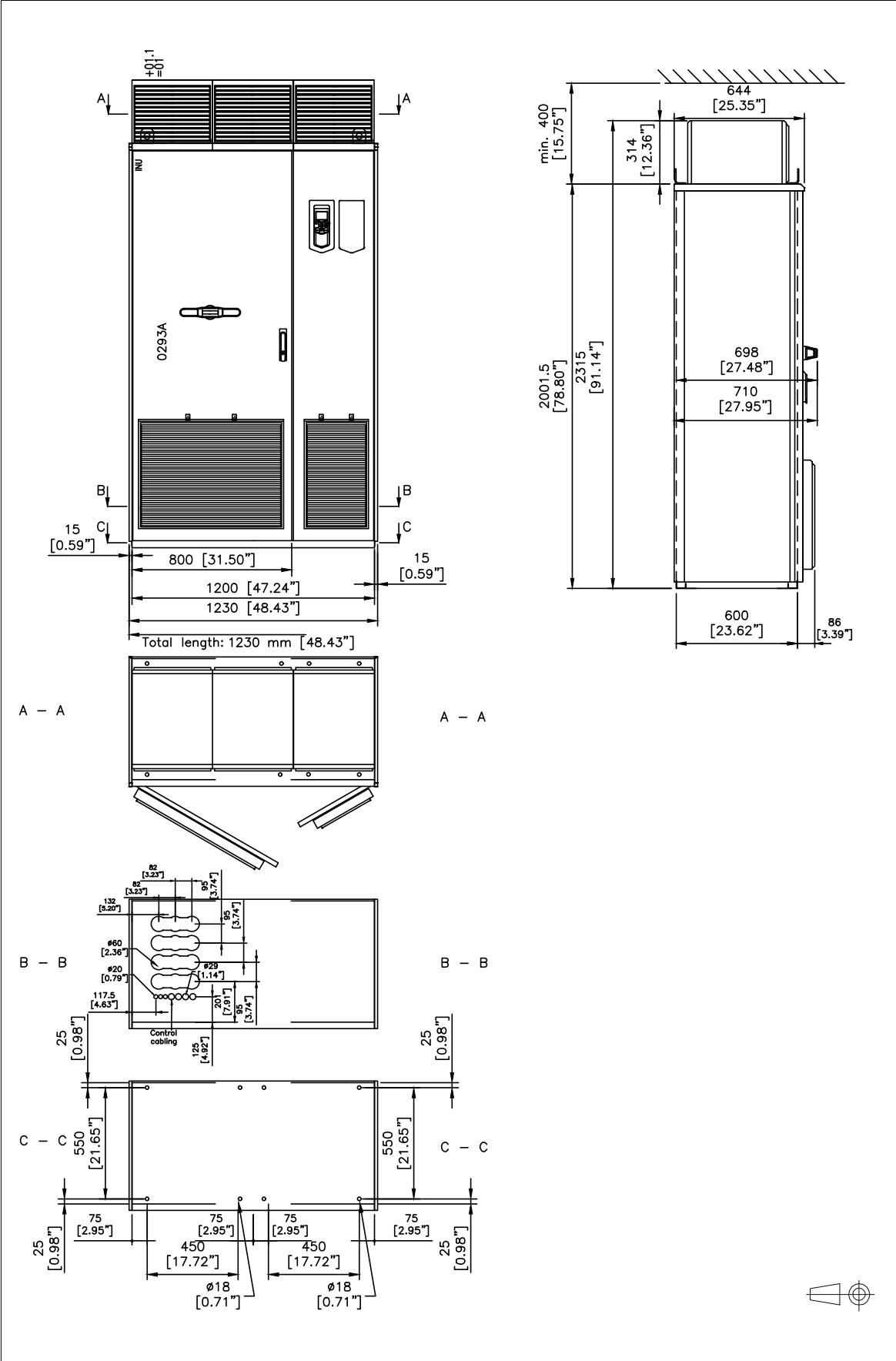

**R11 IP22 (UL Type 1) and IP42 (UL Type 1 Filtered, option +B054): options +C129, +H350, +H352**

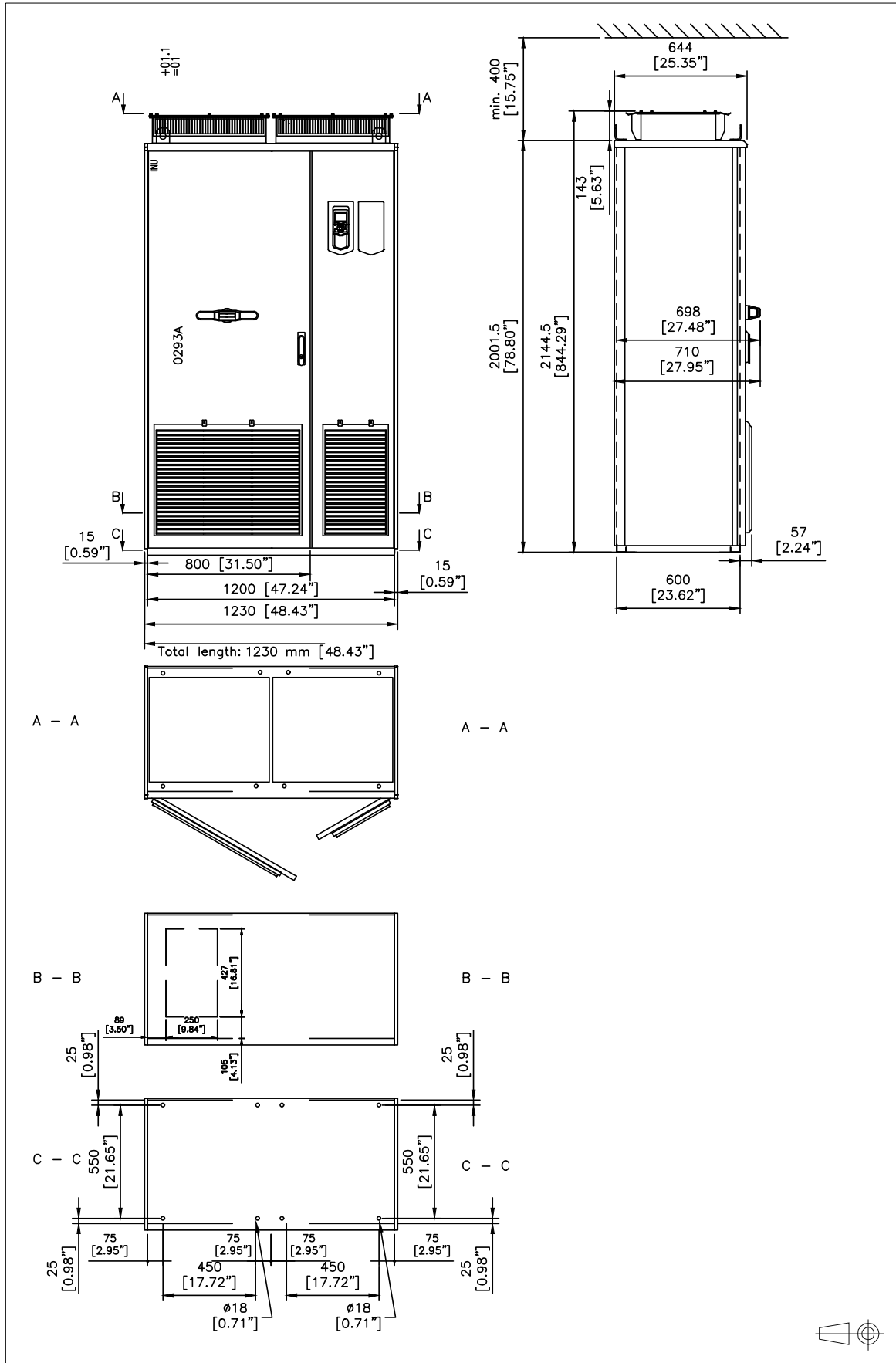

**R11 option +B055 (IP54 [UL Type 12]): option +C128**

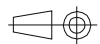
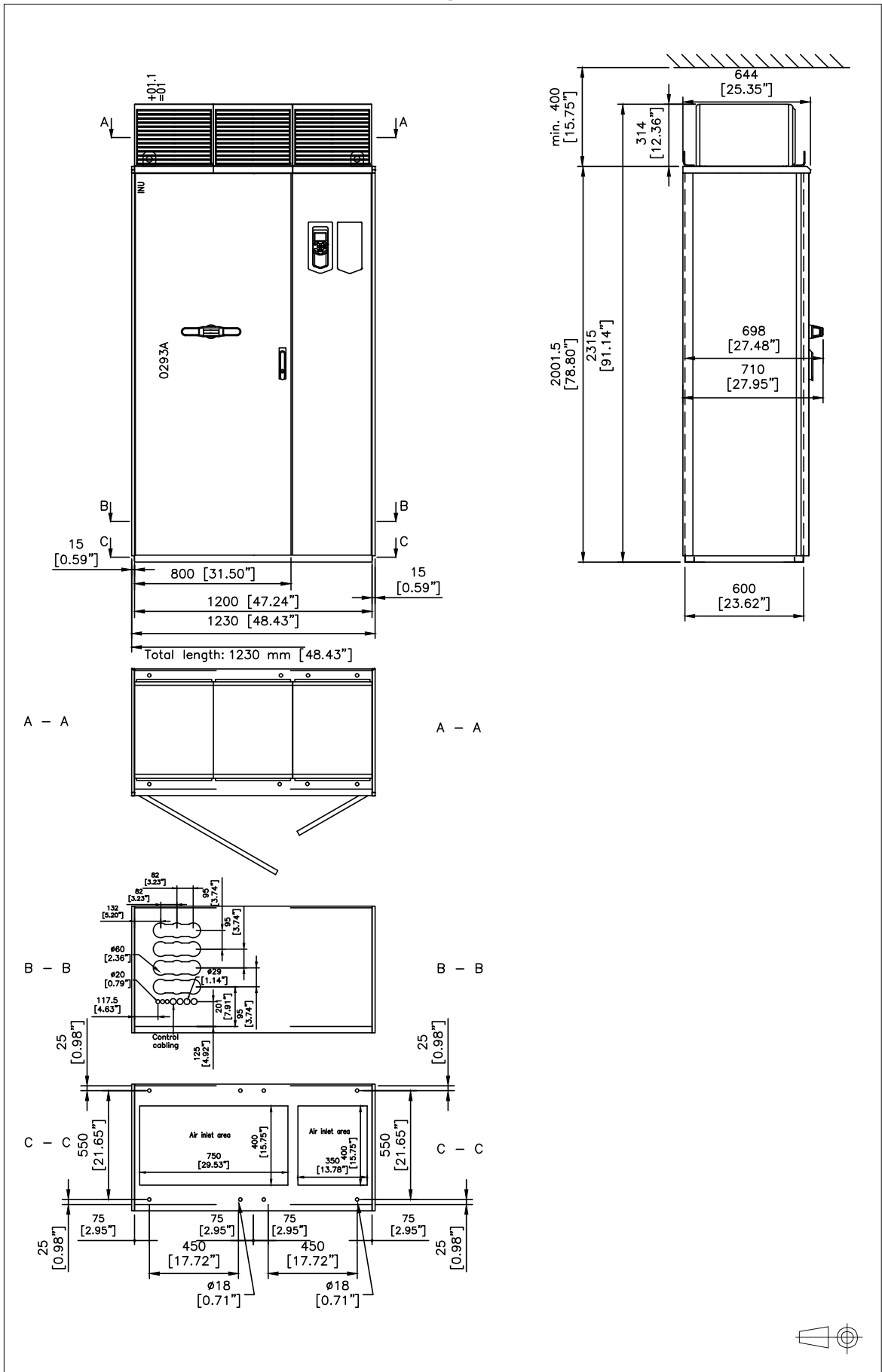

### R11 option +B055 (IP54 [UL Type 12]): option +C129

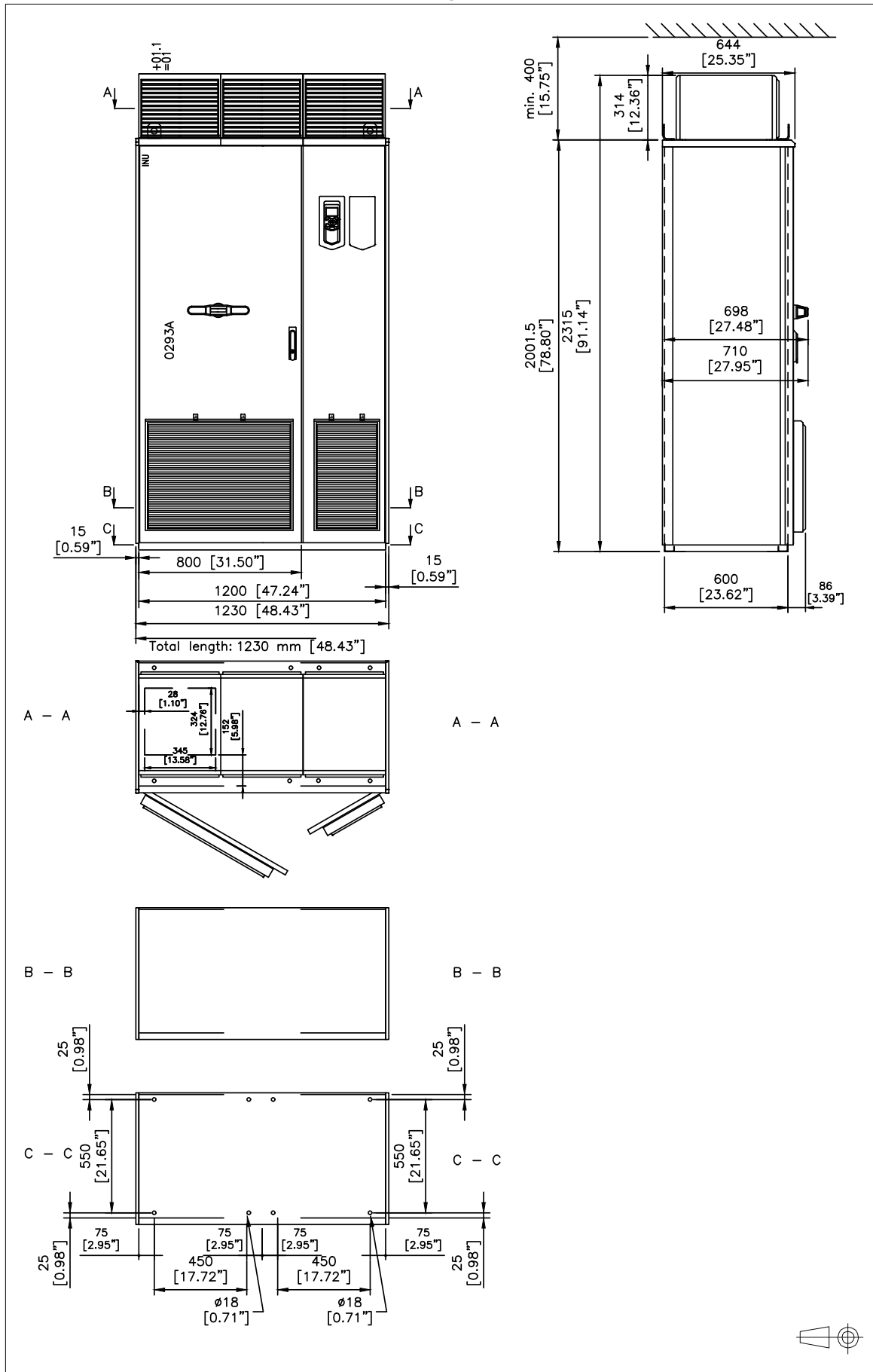

**R11 option +B055 (IP54 [UL Type 12]): options +C129, +H350, +H352**

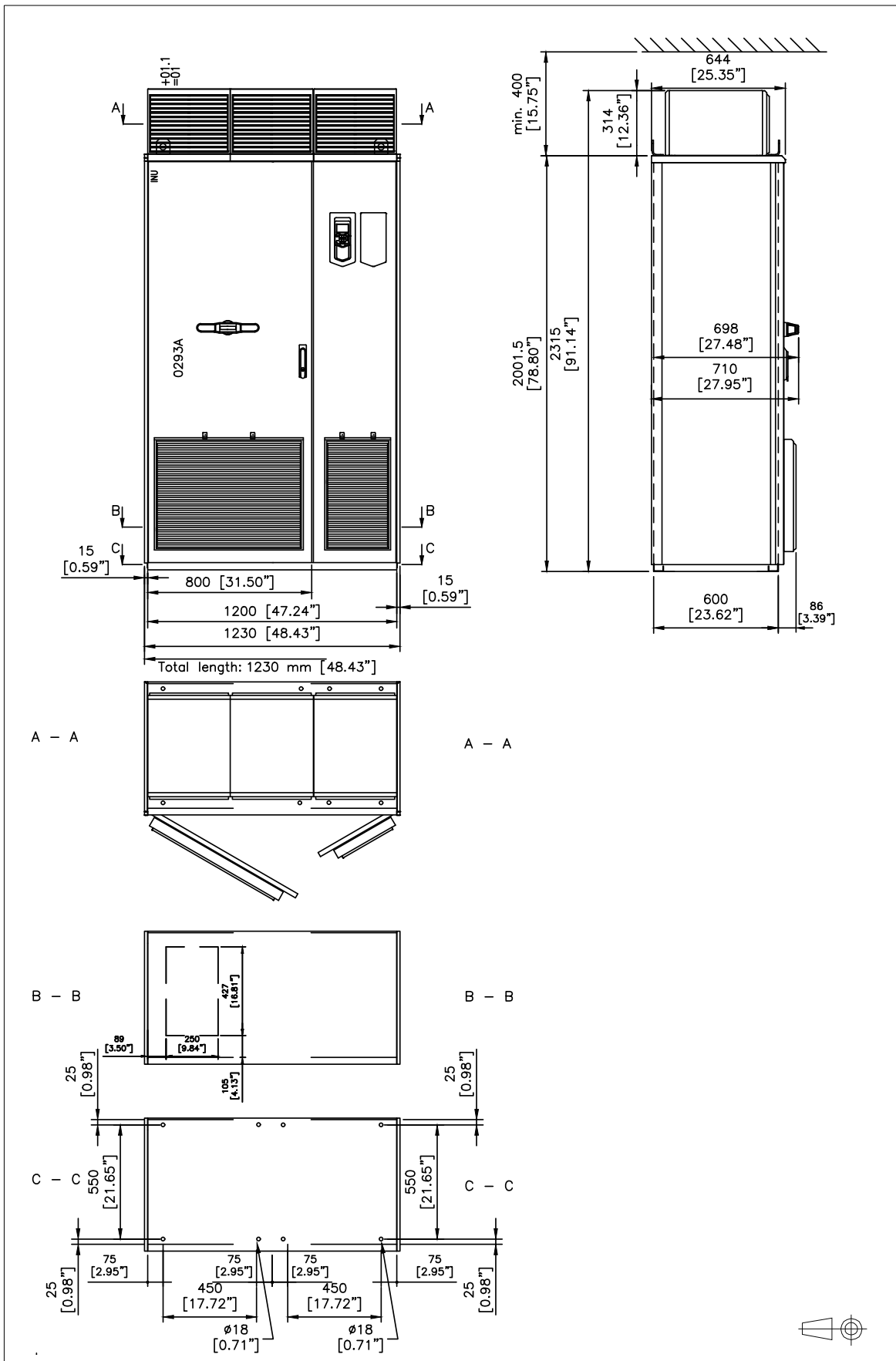

# R11 IP22 (UL Type 1) and IP42 (UL Type 1 Filtered, option +B054): option +D150

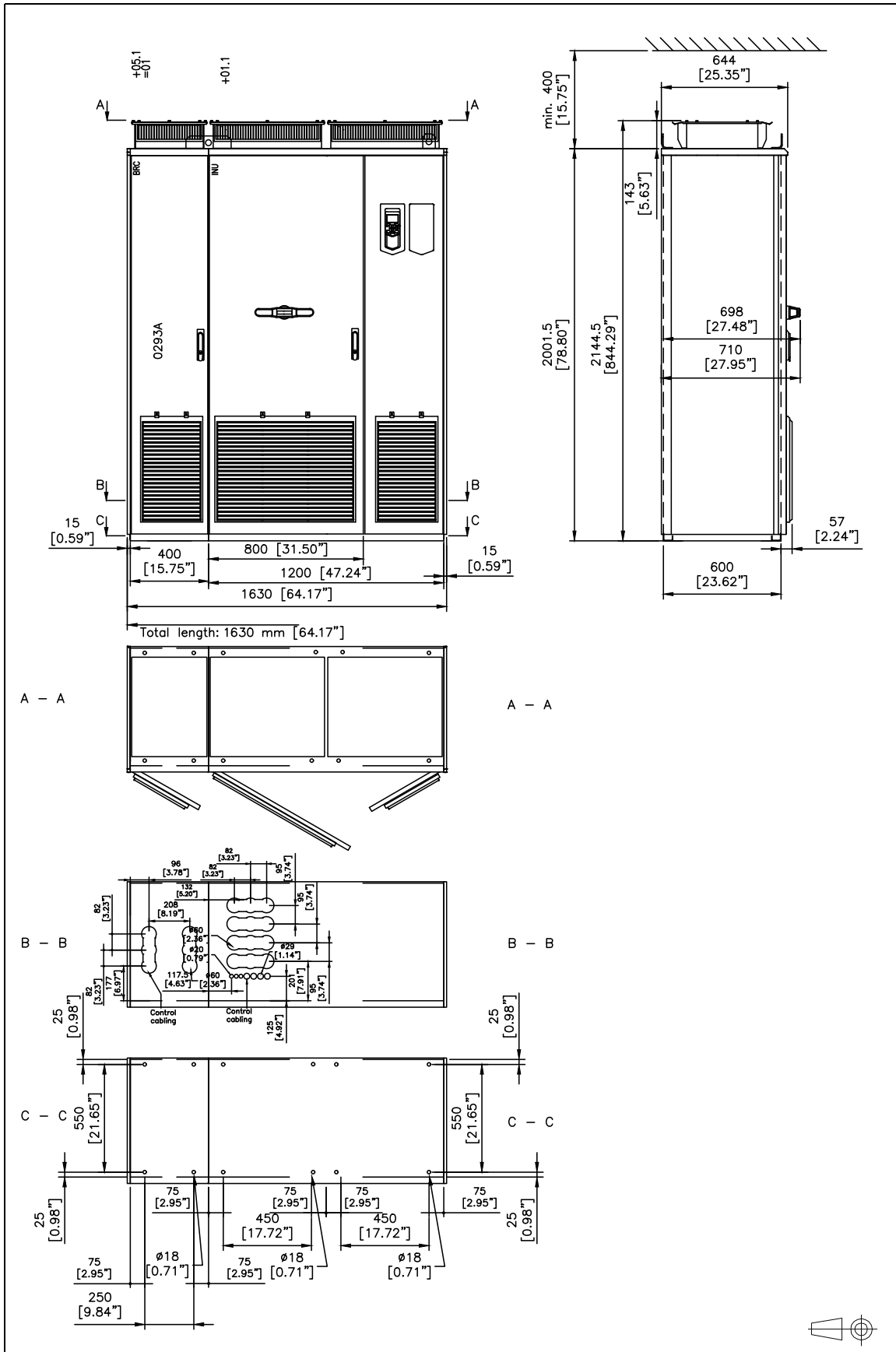

# R11 IP22 (UL Type 1) and IP42 (UL Type 1 Filtered, option +B054): options +D150, +D151

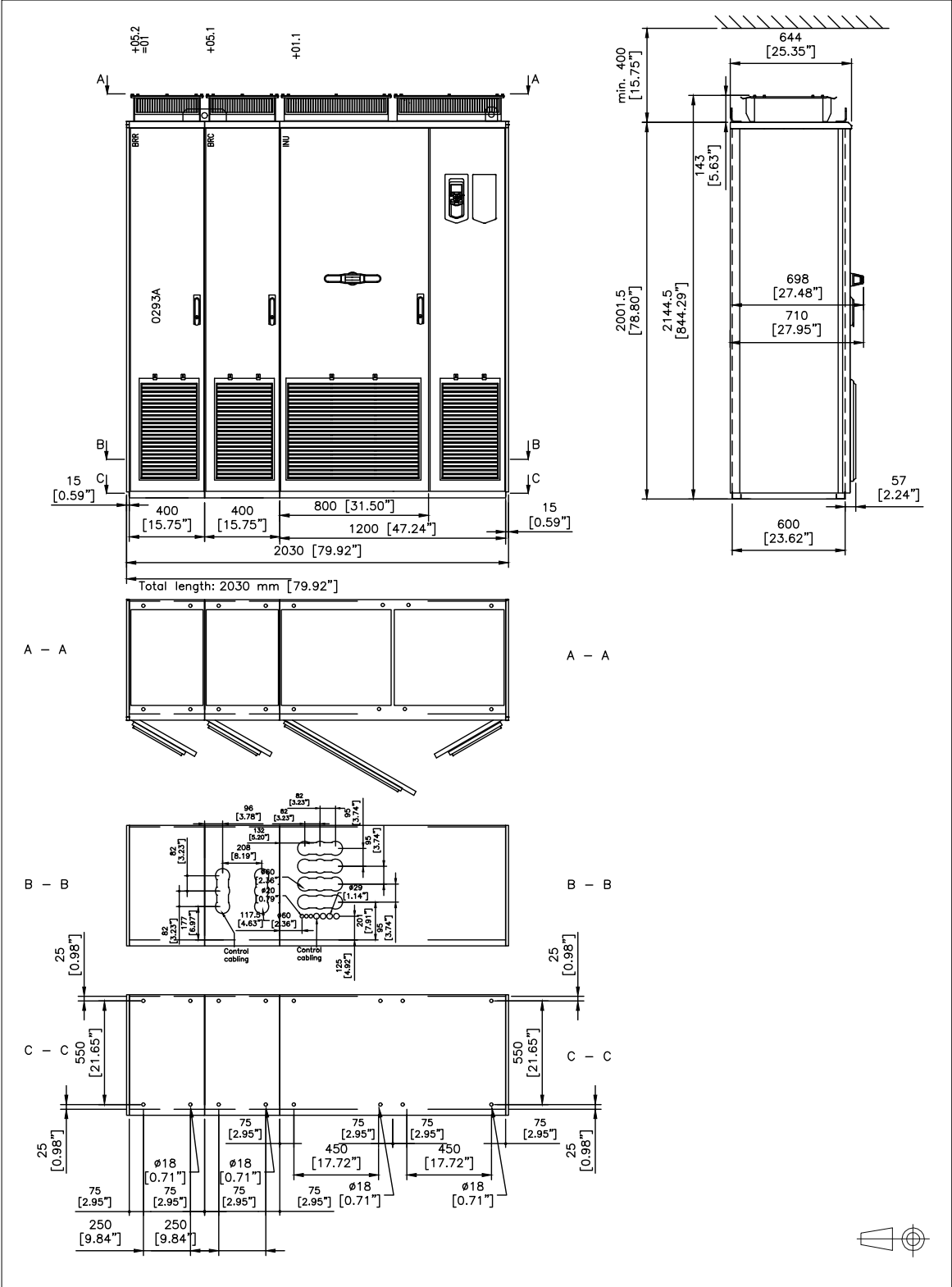

# R11 IP22 (UL Type 1) and IP42 (UL Type 1 Filtered, option +B054): option +E206)

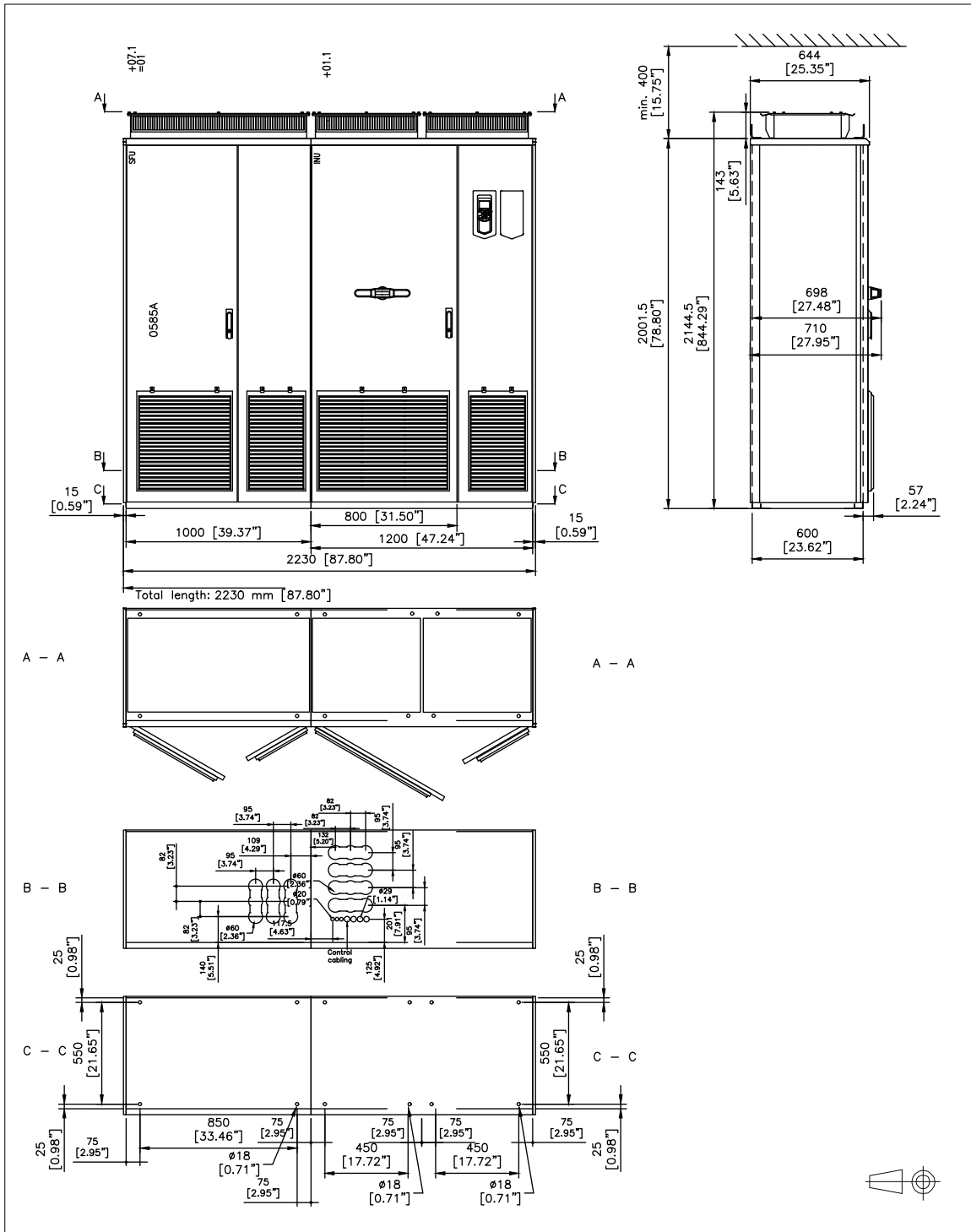



### Location and size of power cable connection terminals

- R8 input and motor cable terminal dimensions – bottom entry and exit

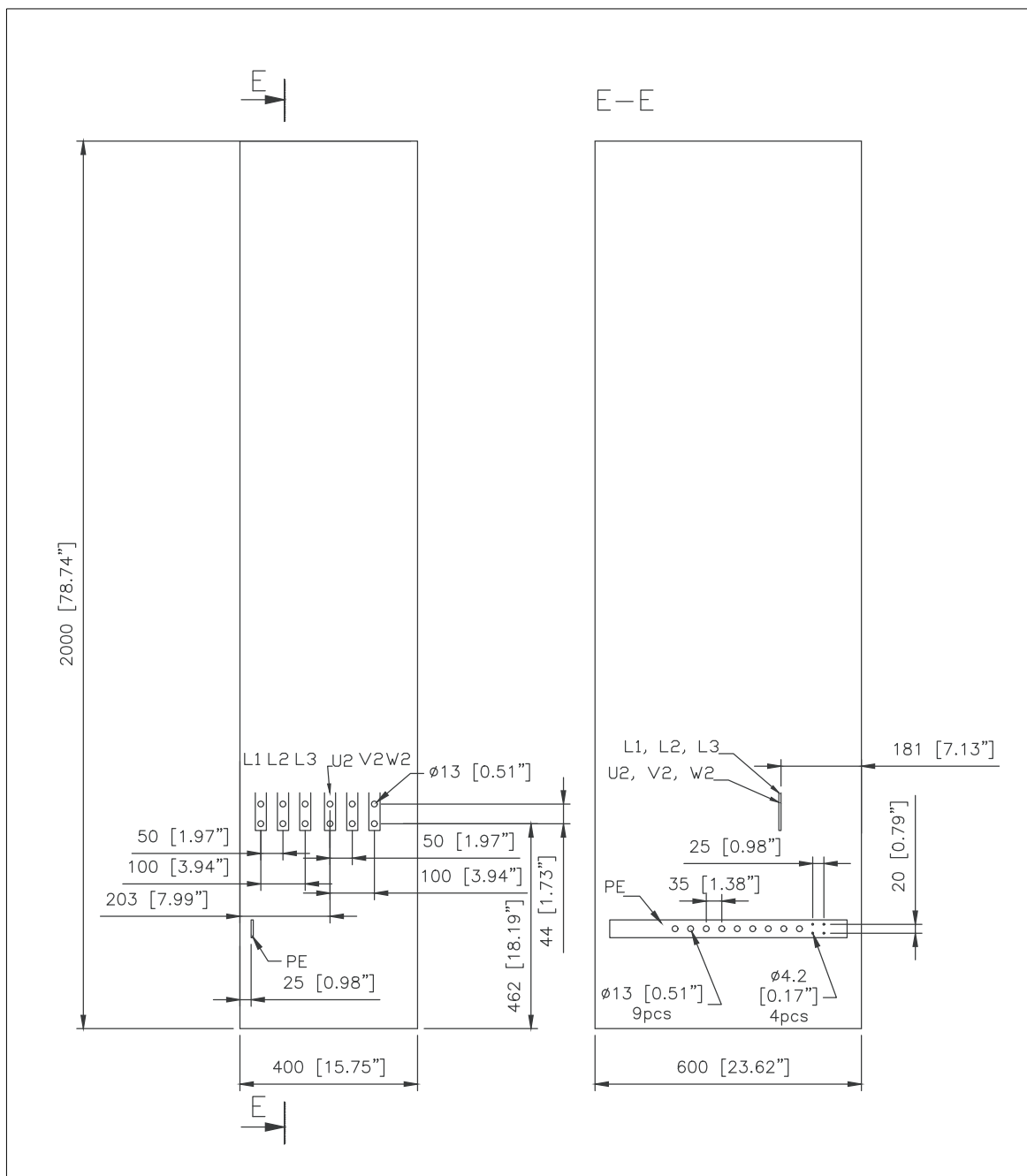

**R8 input and motor cable terminal dimensions – top entry and exit**

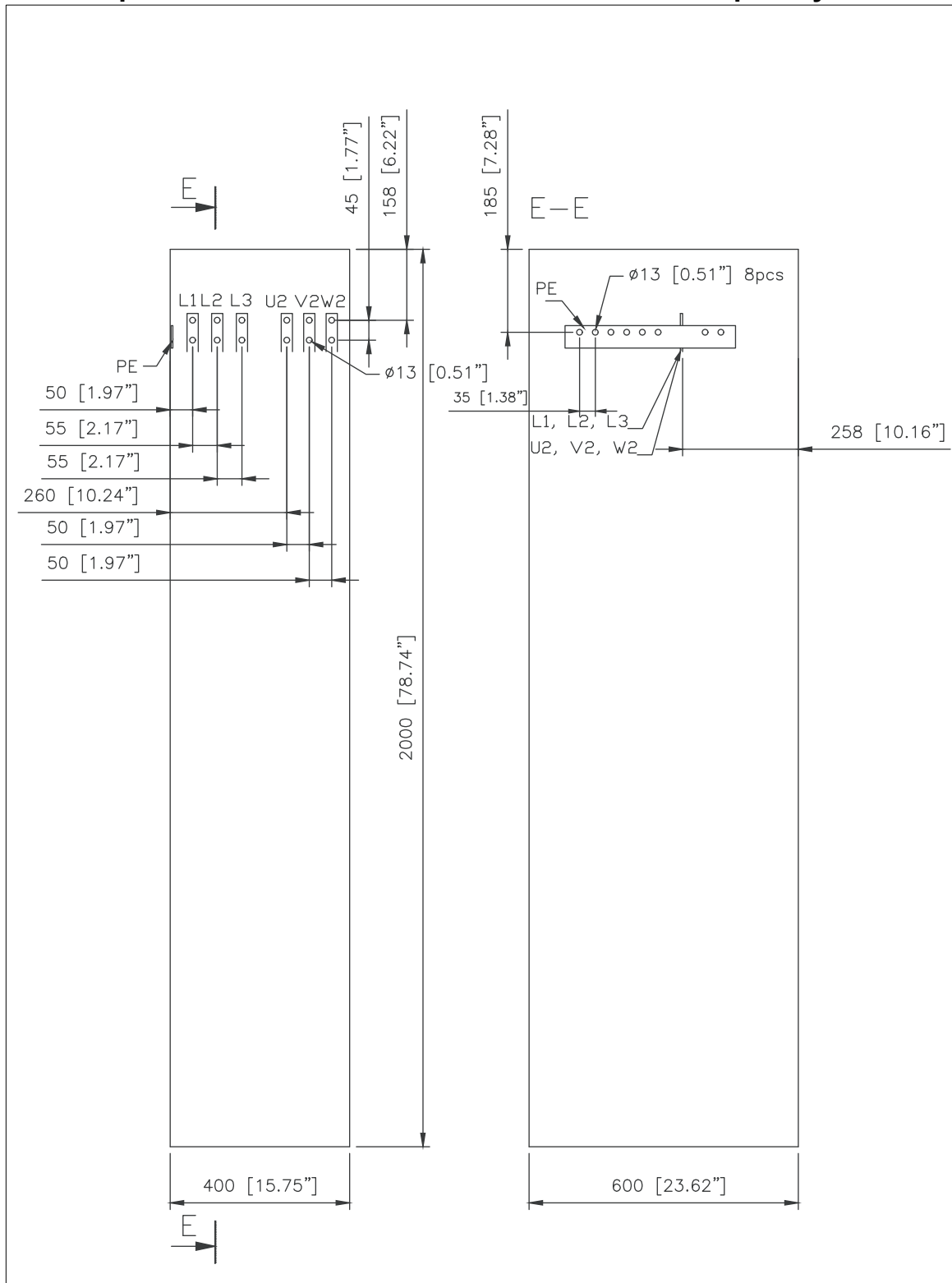

■ R8 input and motor cable terminals

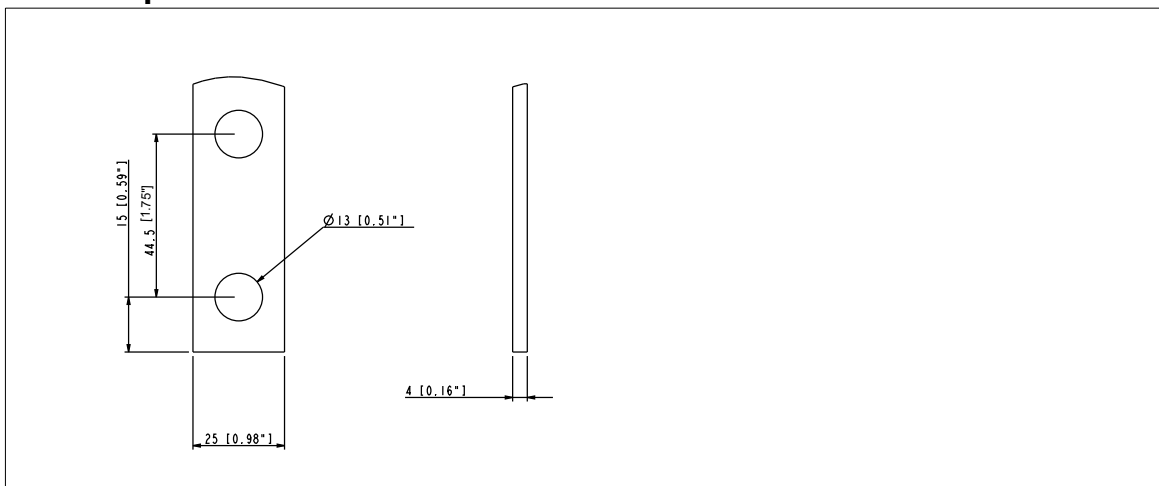

■ R11 input and motor cable terminal dimensions – bottom entry and exit

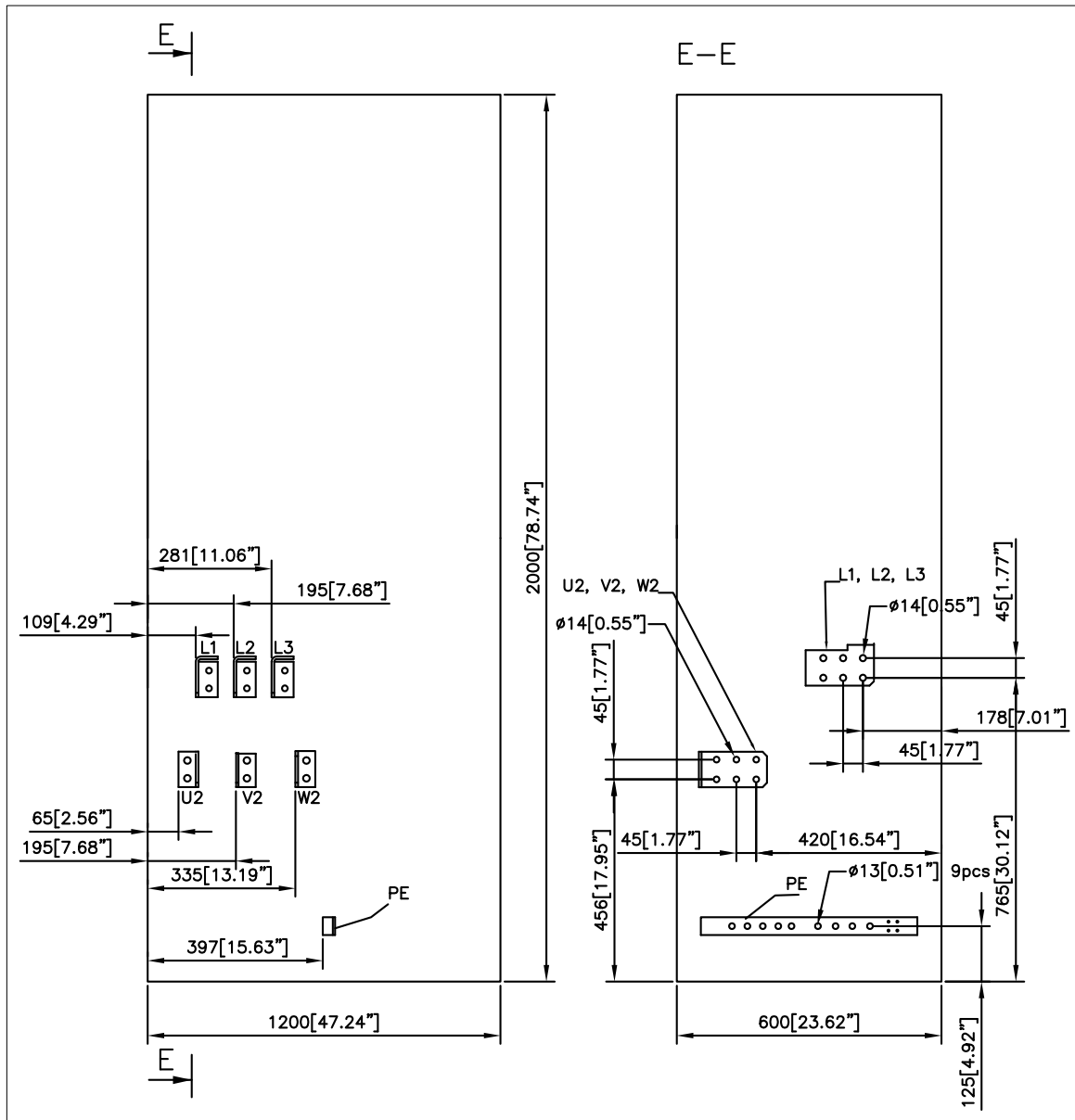

**R11 input and motor cable terminal dimensions – top entry and exit**

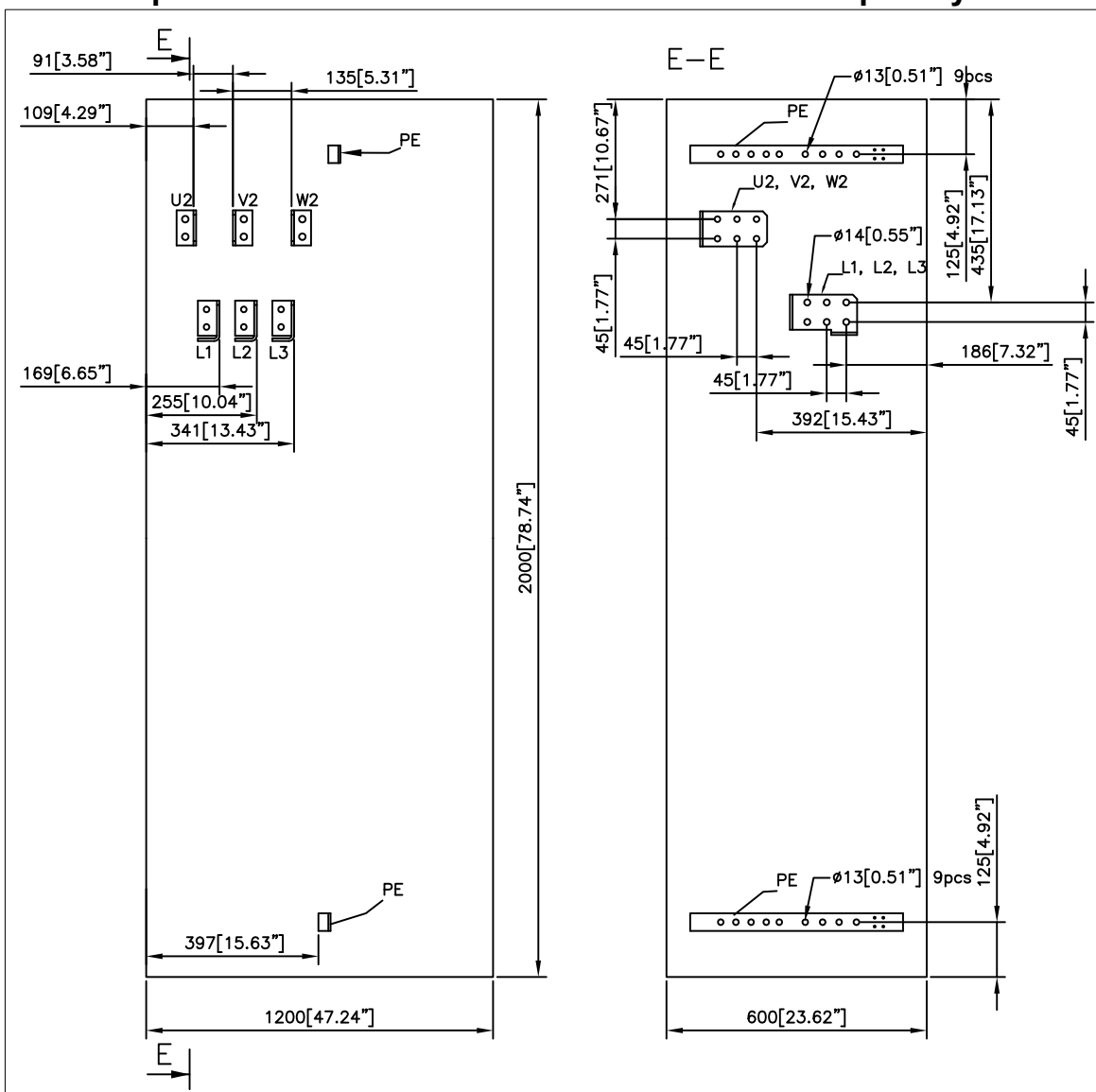

**R11 input cable terminals**

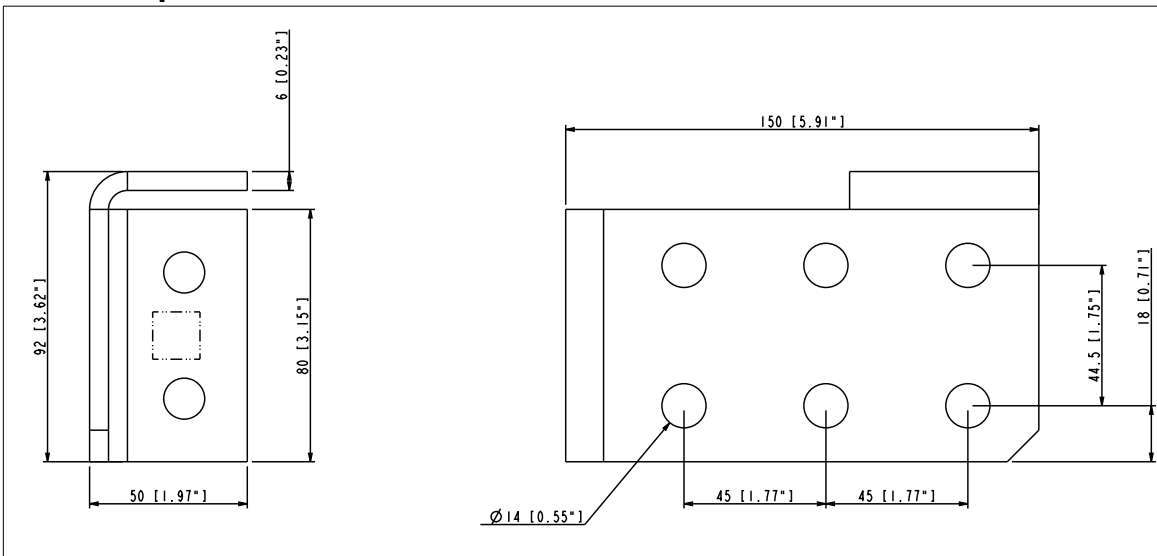

**R11 motor cable terminals**

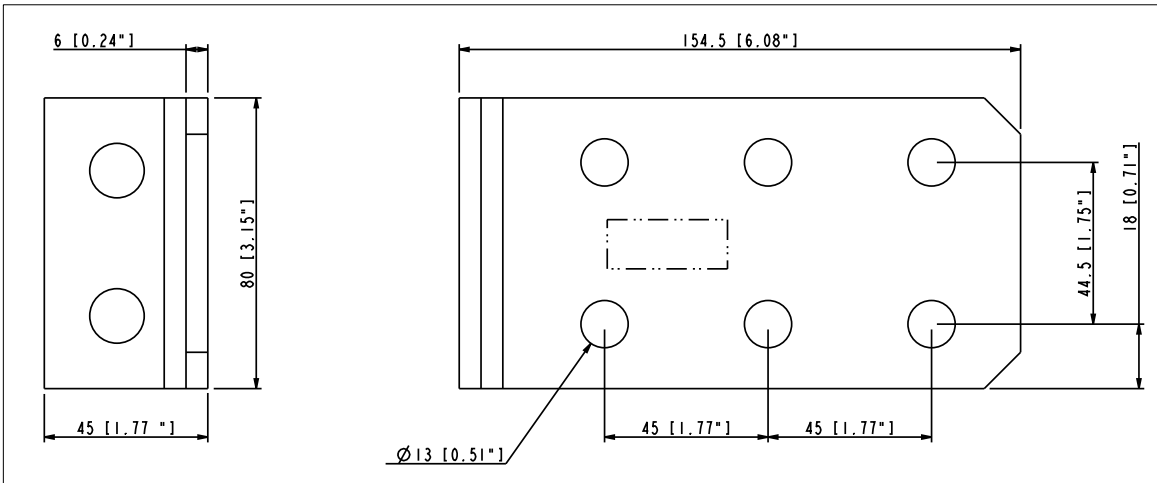

**Terminals for connecting external resistors**

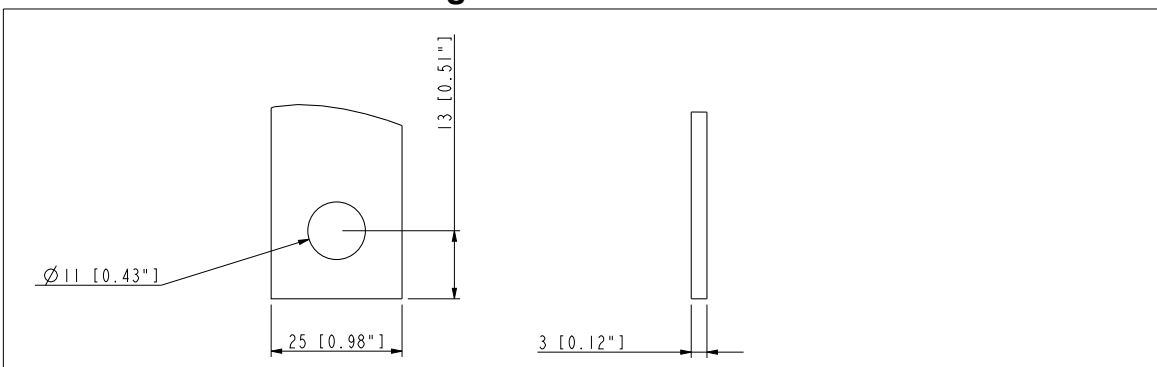

■ Sine filter (+E206) cubicle, 400 mm: motor cable terminals

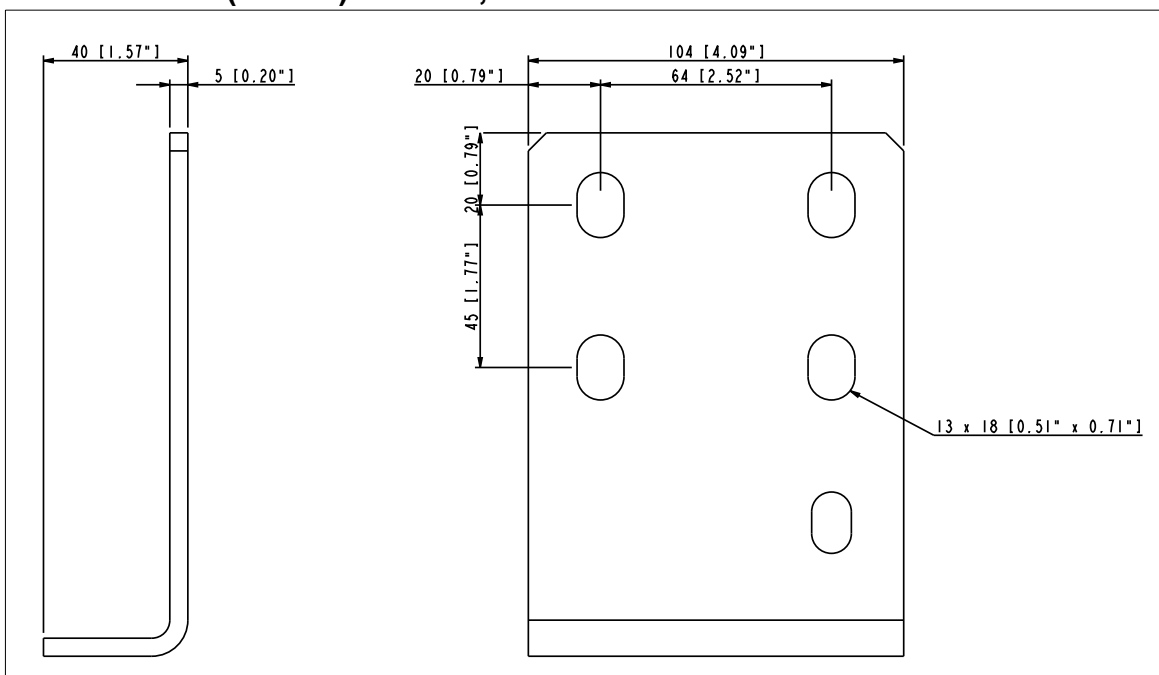

■ Sine filter (+E206) cubicle, 600 mm: motor cable terminals

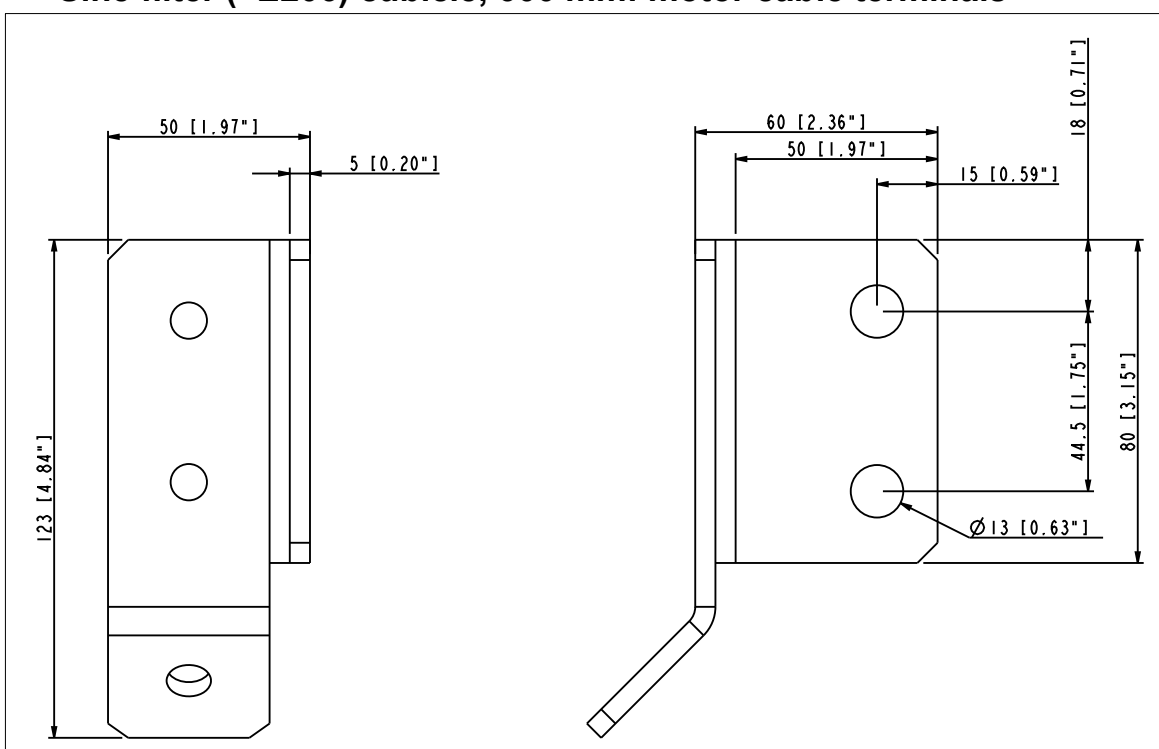

■ Sine filter (+E206) cubicle, 1000 mm: motor cable terminals

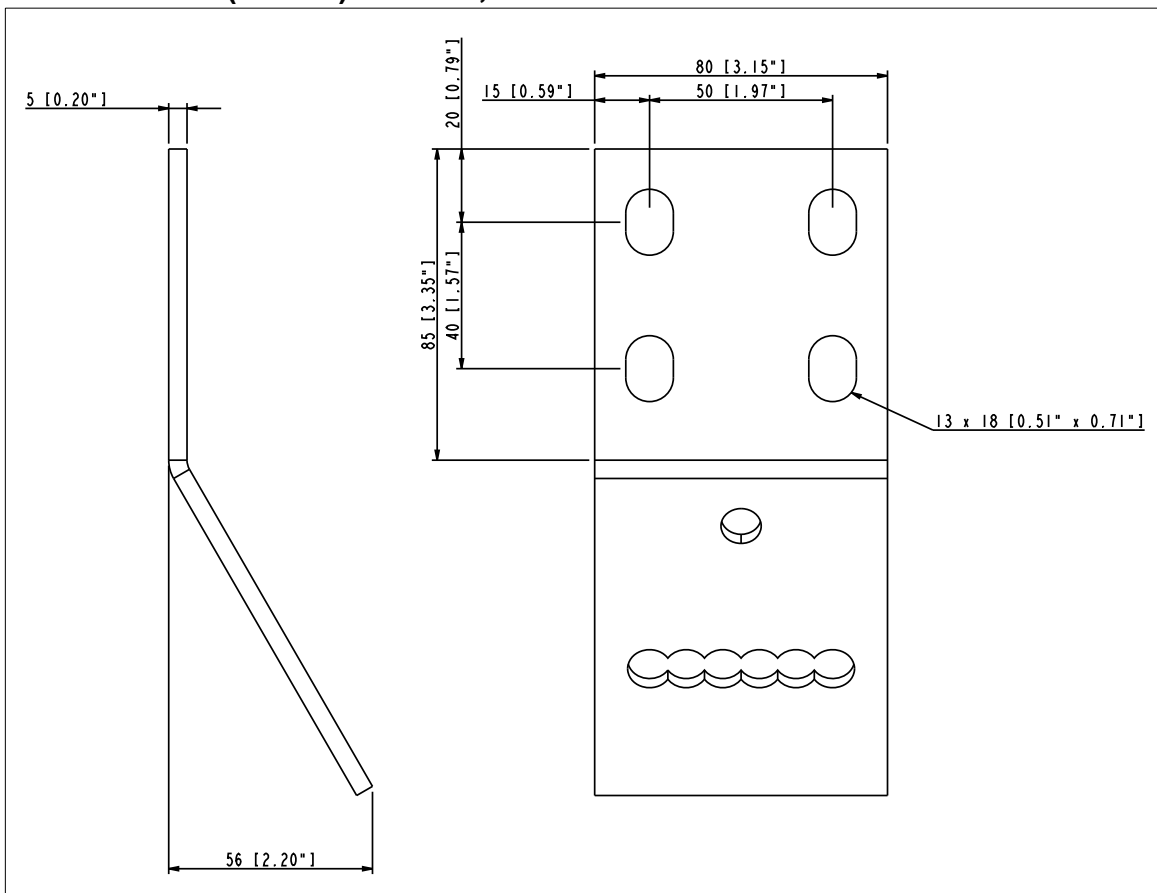



# 15

## The Safe torque off function

---

### Contents of this chapter

This chapter describes the Safe torque off (STO) function of the drive and gives instructions for its use.

### Description

The Safe torque off function can be used, for example, as the final actuator device of safety circuits that stop the drive in case of danger (such as an emergency stop circuit). Another typical application is a prevention of unexpected start-up function that enables short-time maintenance operations like cleaning or work on non-electrical parts of the machinery without switching off the power supply to the drive.

**Note:** The Safe torque off function does not disconnect the voltage from the drive, see the warning on page [273](#).

When activated, the Safe torque off function disables the control voltage of the power semiconductors of the drive output stage (A, see the diagram below), thus preventing the drive from generating the torque required to rotate the motor. If the motor is running when Safe torque off is activated, it coasts to a stop.

The Safe torque off function has a redundant architecture, that is, both channels must be used in the safety function implementation. The safety data given in this manual is calculated for redundant use, and does not apply if both channels are not used.

The Safe torque off function complies with these standards:

Standard	Name
IEC 60204-1:2016 EN 60204-1:2006 + A1:2009 + AC:2010	<i>Safety of machinery – Electrical equipment of machines – Part 1: General requirements</i>

---

Standard	Name
IEC 61000-6-7:2014	<i>Electromagnetic compatibility (EMC) - Part 6-7: Generic standards - Immunity requirements for equipment intended to perform functions in a safety-related system (functional safety) in industrial locations</i>
IEC 61326-3-1:2017	<i>Electrical equipment for measurement, control and laboratory use – EMC requirements – Part 3-1: Immunity requirements for safety-related systems and for equipment intended to perform safety-related functions (functional safety) – General industrial applications</i>
IEC 61508-1:2010	<i>Functional safety of electrical/electronic/programmable electronic safety-related systems – Part 1: General requirements</i>
IEC 61508-2:2010	<i>Functional safety of electrical/electronic/programmable electronic safety-related systems – Part 2: Requirements for electrical/electronic/programmable electronic safety-related systems</i>
IEC 61511-1:2016	<i>Functional safety – Safety instrumented systems for the process industry sector</i>
EN 61800-5-2:2007 IEC 61800-5-2:2016	<i>Adjustable speed electrical power drive systems – Part 5-2: Safety requirements – Functional</i>
IEC 62061:2005 + A1:2012 + A2:2015 EN 62061:2005 +AC:2010+A1:2013+A2:2015	<i>Safety of machinery – Functional safety of safety-related electrical, electronic and programmable electronic control systems</i>
EN ISO 13849-1:2015	<i>Safety of machinery – Safety-related parts of control systems – Part 1: General principles for design</i>
EN ISO 13849-2:2012	<i>Safety of machinery – Safety-related parts of control systems – Part 2: Validation</i>

The function also corresponds to Prevention of unexpected start-up as specified by EN 1037:1995 + A1:2008 and Uncontrolled stop (stop category 0) as specified in EN 60204-1.

## ■ Compliance with the European Machinery Directive

See section [Compliance with the European Machinery Directive](#) on page 235.

## Wiring

The following diagrams present examples of Safe torque off wiring for

- a single drive (page 268)
- multiple drives (page 269)
- multiple drives when an external 24 V DC power supply is used (page 270).

For information on the specifications of the STO input, see chapter [Control unit of frame R8](#) (page 141) and [Control unit of frame R11](#) (page 151).

## ■ Activation switch

In the wiring diagrams below, the activation switch has the designation [K]. This represents a component such as a manually operated switch, an emergency stop push button switch, or the contacts of a safety relay or safety PLC.

- If a manually operated activation switch is used, the switch must be of a type that can be locked out to the open position.
- The contacts of the switch or relay must open/close within 200 ms of each other.
- An FSO-xx safety functions module or an FPTC-0x thermistor protection module can also be used. For more information, see the module documentation.

## ■ Cable types and lengths

- Double-shielded twisted-pair cable is recommended.
- Maximum cable lengths:
  - 300 m (984 ft) between activation switch [K] and drive control unit
  - 60 m (200 ft) between multiple drives
  - 60 m (200 ft) between external power supply and first drive.

**Note:** The voltage at the STO input terminals of each drive control unit must be at least 17 V DC to be interpreted as “1”.

## ■ Grounding of protective shields

- Ground the shield in the cabling between the activation switch and the control unit at the control unit.
  - Ground the shield in the cabling between two control units at one control unit only.
-

■ Single drive (internal power supply)

Dual-channel connection

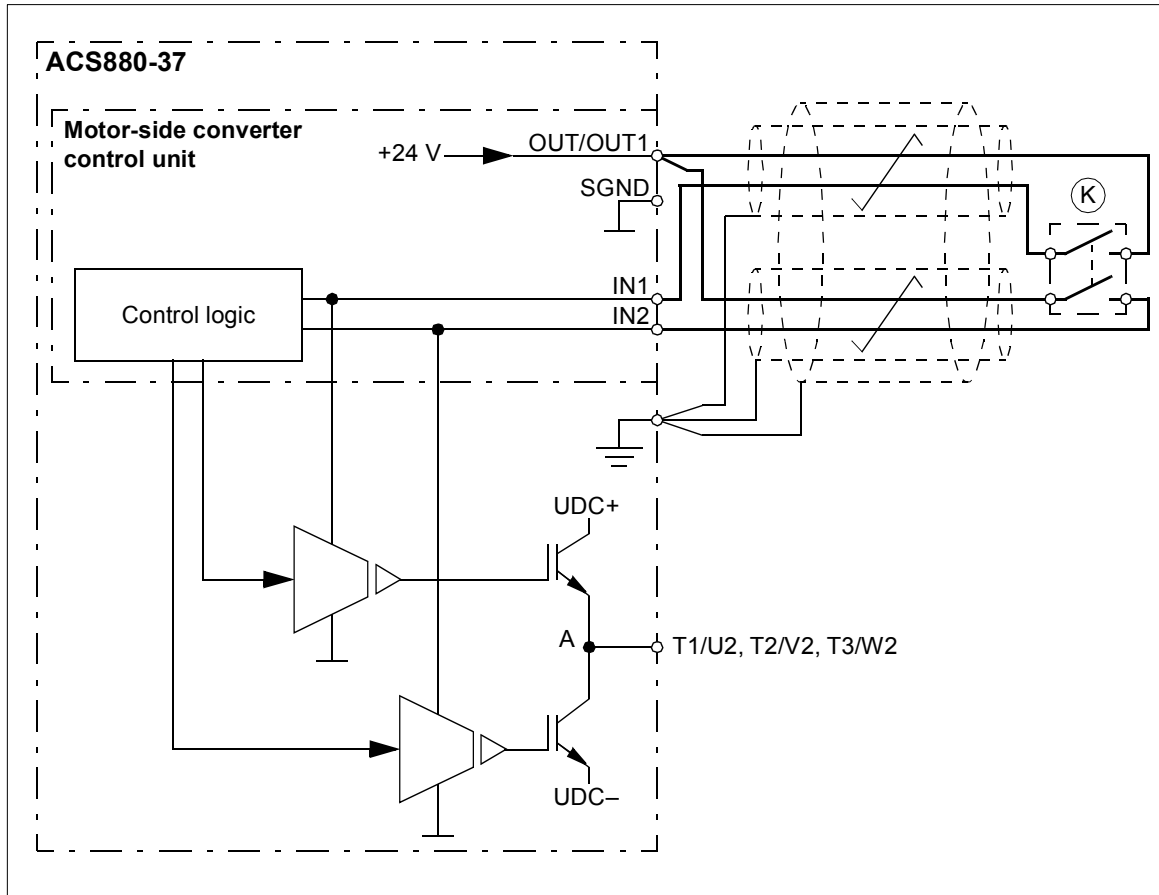

Single-channel connection

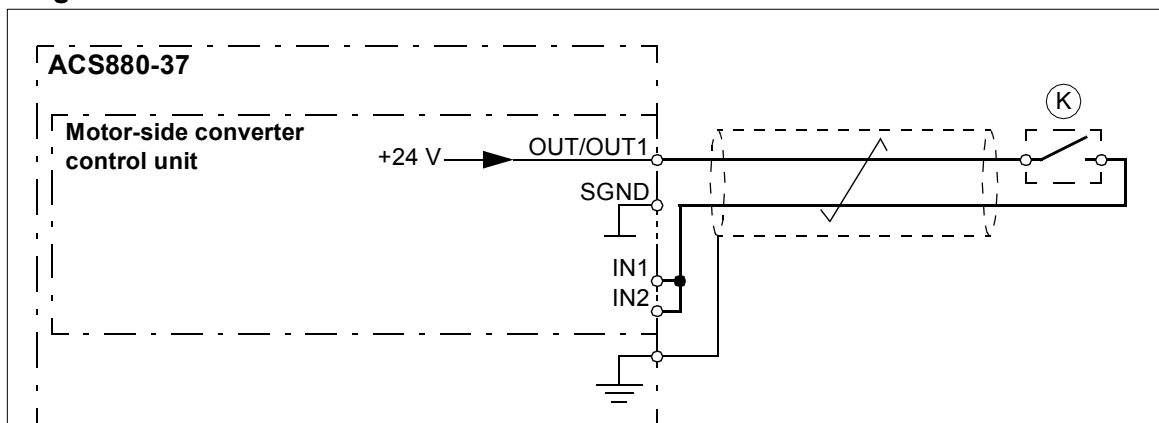

Notes:

- Both STO inputs (IN1, IN2) must be connected to the activation switch. Otherwise, no SIL/PL classification is given.
- Pay special attention to avoiding any potential failure modes for the wiring. For example, use shielded cable. For measures for fault exclusion of wiring, see eg. EN ISO 13849-2:2012, table D.4.

■ Multiple drives (internal power supply)

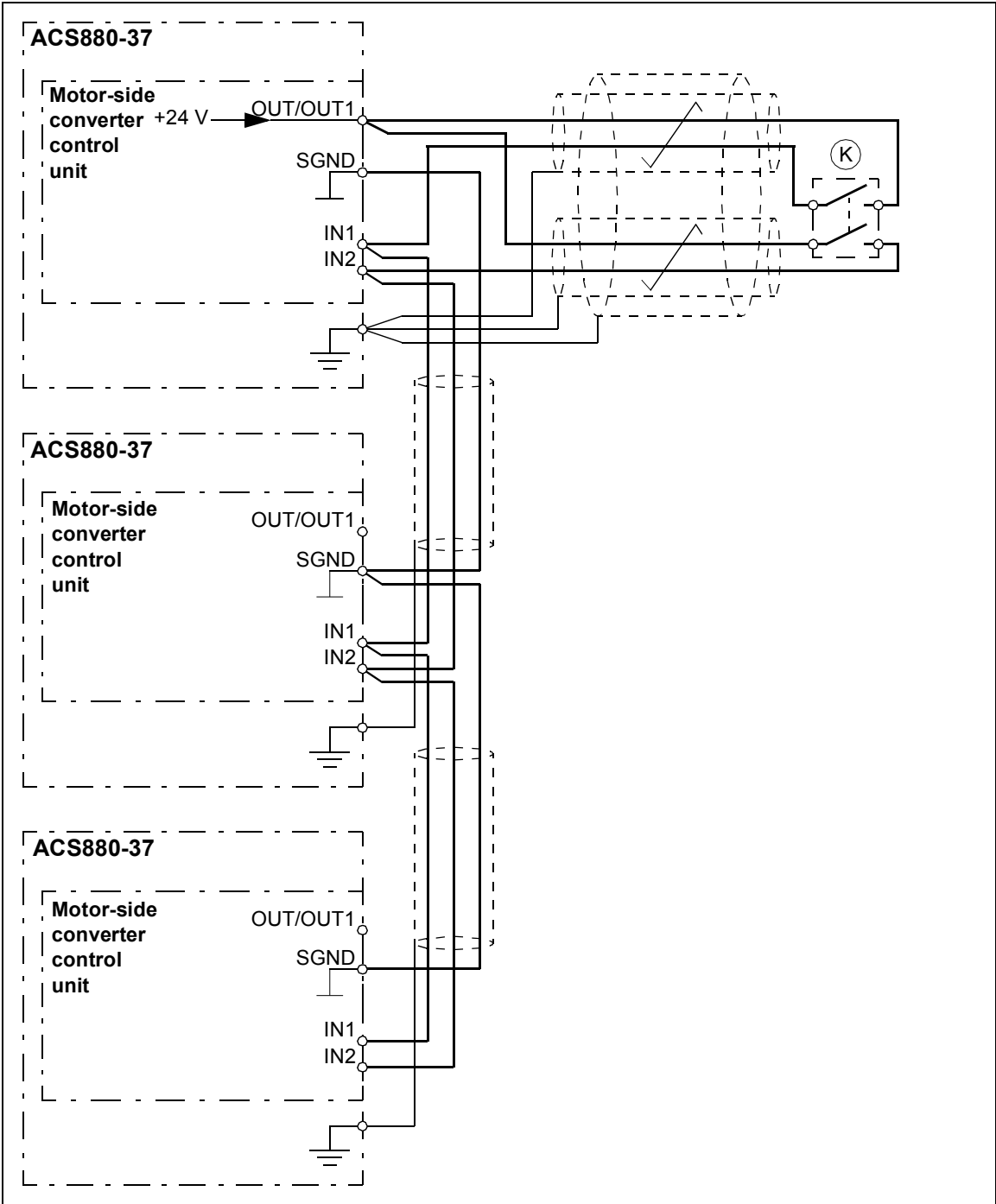

■ Multiple drives (external power supply)

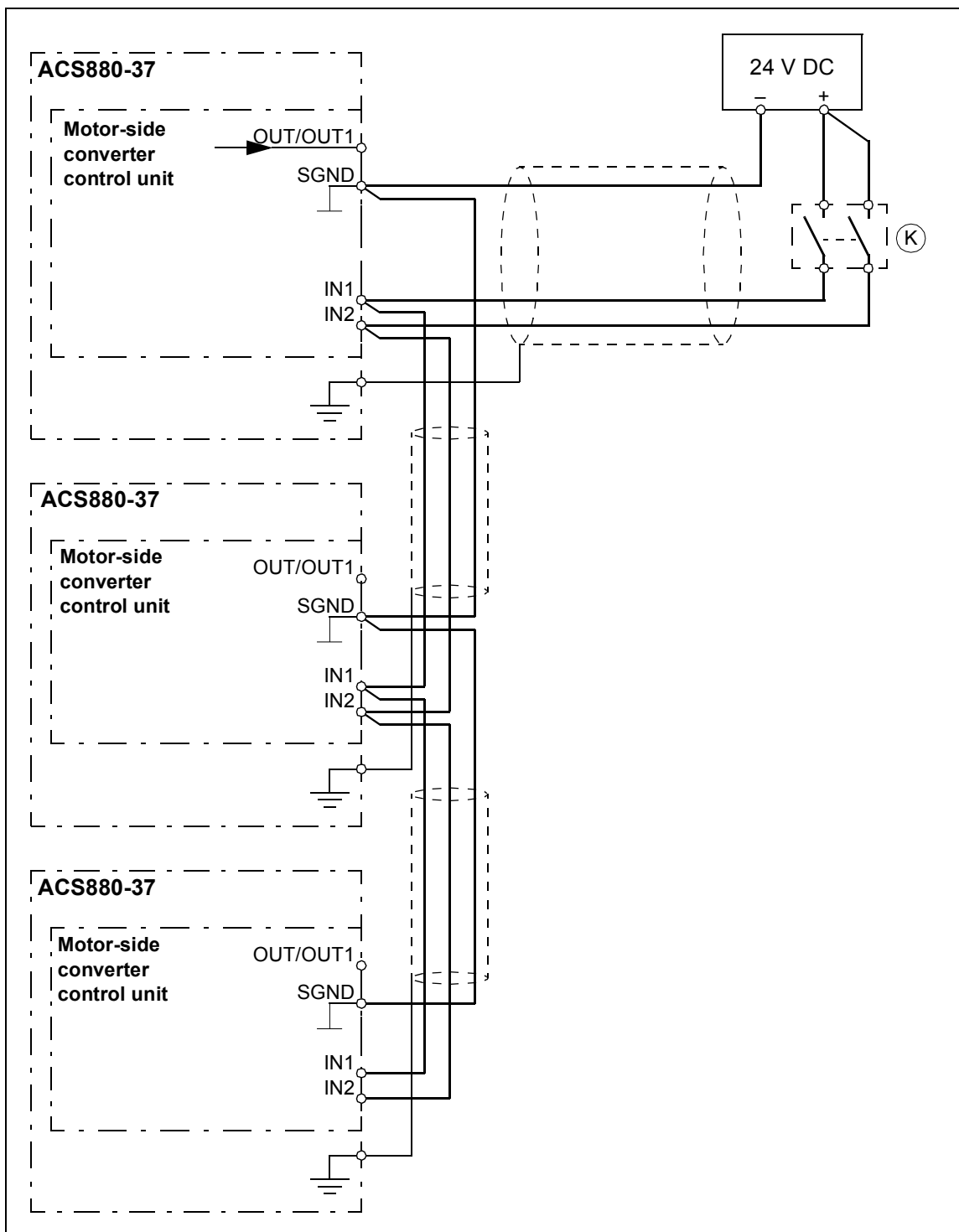

### Operation principle

1. The Safe torque off activates (the activation switch is opened, or safety relay contacts open).
2. The STO inputs on the motor-side converter control unit de-energize.
3. The control unit cuts off the control voltage from the output IGBTs.

4. The control program generates an indication as defined by parameter 31.22 (refer to the firmware manual of the motor-side converter).
5. The motor coasts to a stop (if running). The drive cannot restart while the activation switch or safety relay contacts are open. After the contacts close, a reset may be needed (depending on the setting of parameter 31.22). A new start command is required to start the drive.

## Start-up including acceptance test

To ensure the safe operation of a safety function, validation is required. The final assembler of the machine must validate the function by performing an acceptance test. The acceptance test must be performed

- at initial start-up of the safety function
- after any changes related to the safety function (circuit boards, wiring, components, settings, etc.)
- after any maintenance work related to the safety function.

### ■ Competence

The acceptance test of the safety function must be carried out by a competent person with adequate expertise and knowledge of the safety function as well as functional safety, as required by IEC 61508-1 clause 6. The test procedures and report must be documented and signed by this person.

### ■ Acceptance test reports

Signed acceptance test reports must be stored in the logbook of the machine. The report shall include documentation of start-up activities and test results, references to failure reports and resolution of failures. Any new acceptance tests performed due to changes or maintenance shall be logged into the logbook.

### ■ Acceptance test procedure

After wiring the Safe torque off function, validate its operation as follows.

**Note:** If the drive is equipped with safety option +L536, +L537, +Q950, +Q951, +Q952, +Q957, +Q963, +Q964, +Q978 or +Q979, do the procedure shown in the documentation of the option. If the drive is equipped with safety functions module FSO-12, FSO-21, safety option +Q972, +Q973, +Q982 or thermistor protection module FPTC-01/-02 (option +L536 or + L537), do the procedure shown in the FSO/FPTC module documentation.

Action	<input checked="" type="checkbox"/>
 <b>WARNING!</b> Follow the safety instructions given in chapter <a href="#">Safety instructions</a> (page 15). If you ignore them, injury or death, or damage to the equipment can occur.	<input type="checkbox"/>
Ensure that the drive can be run and stopped freely during start-up.	<input type="checkbox"/>
Stop the drive (if running), switch the input power off and isolate the drive from the power line by a disconnecter.	<input type="checkbox"/>
Check the Safe torque off circuit connections against the wiring diagram.	<input type="checkbox"/>
Close the disconnecter and switch the power on.	<input type="checkbox"/>

<b>Action</b>	<input checked="" type="checkbox"/>
<p>Test the operation of the STO function when the motor is stopped.</p> <ul style="list-style-type: none"> <li>• Give a stop command to the drive (if running) and wait until the motor shaft is at a standstill.</li> </ul> <p>Ensure that the drive operates as follows:</p> <ul style="list-style-type: none"> <li>• Open the STO circuit. The drive generates an indication if one is defined for 'stopped' state in parameter 31.22 (see the firmware manual).</li> <li>• Give a start command to verify that the STO function blocks the drive's operation. The motor should not start.</li> <li>• Close the STO circuit.</li> <li>• Reset any active faults. Restart the drive and check that the motor runs normally.</li> </ul>	<input type="checkbox"/>
<p>Test the operation of the STO function when the motor is running.</p> <ul style="list-style-type: none"> <li>• Start the drive and ensure the motor is running.</li> <li>• Open the STO circuit. The motor should stop. The drive generates an indication if one is defined for 'running' state in parameter 31.22 (see the firmware manual).</li> <li>• Reset any active faults and try to start the drive.</li> <li>• Ensure that the motor stays at a standstill and the drive operates as described above in testing the operation when the motor is stopped.</li> <li>• Close the STO circuit.</li> <li>• Reset any active faults. Restart the drive and check that the motor runs normally.</li> </ul>	<input type="checkbox"/>
<p>Test the operation of the failure detection of the drive. The motor can be stopped or running.</p> <ul style="list-style-type: none"> <li>• Open the 1st channel of the STO circuit (wire coming to IN1). If the motor was running, it should coast to a stop. The drive generates a <i>FA81 Safe Torque Off 1 loss</i> fault indication (see the firmware manual).</li> <li>• Give a start command to verify that the STO function blocks the drive's operation. The motor should not start.</li> <li>• Close the STO circuit.</li> <li>• Reset any active faults. Restart the drive and check that the motor runs normally.</li> <li>• Open the 2nd channel of the STO circuit (wire coming to IN2). If the motor was running, it should coast to a stop. The drive generates a <i>FA82 Safe Torque Off 2 loss</i> fault indication (see the firmware manual).</li> <li>• Give a start command to verify that the STO function blocks the drive's operation. The motor should not start.</li> <li>• Close the STO circuit.</li> <li>• Reset any active faults. Restart the drive and check that the motor runs normally.</li> </ul>	<input type="checkbox"/>
<p>Document and sign the acceptance test report which verifies that the safety function is safe and accepted for operation.</p>	<input type="checkbox"/>

## Use

1. Open the activation switch, or activate the safety functionality that is wired to the STO connection.
  2. The STO inputs of the motor-side converter control unit de-energize, and the drive control unit cuts off the control voltage from the drive IGBTs.
  3. The control program generates an indication as defined by parameter 31.22 (refer to the firmware manual of the drive).
  4. The motor coasts to a stop (if running). The drive will not restart while the activation switch or safety relay contacts are open.
  5. Deactivate the STO by closing the activation switch, or resetting the safety functionality that is wired to the STO connection.
  6. Reset any faults before restarting.
-





**WARNING!** The Safe torque off function does not disconnect the voltage of the main and auxiliary circuits from the drive. Therefore maintenance work on electrical parts of the drive or the motor can only be carried out after isolating the drive from all possible voltage sources.



**WARNING!** The Safe torque off functionality is only achieved through the XSTO connector of the motor-side converter control unit. True Safe torque off functionality is not achieved through the XSTO connectors of the line-side converter control unit.

The Safe torque off function is supported by any ACS880 motor-side converter firmware. It is not supported by line-side converter or brake firmware.



**WARNING!** (With permanent magnet or synchronous reluctance [SynRM] motors only) In case of a multiple IGBT power semiconductor failure, the drive system can produce an alignment torque which maximally rotates the motor shaft by  $180/p$  (with permanent magnet motors) or  $180/2p$  (with synchronous reluctance [SynRM] motors) degrees regardless of the activation of the Safe torque off function.  $p$  denotes the number of pole pairs.

---

#### Notes:

- If a running drive is stopped by using the Safe torque off function, the drive will cut off the motor supply voltage and the motor will coast to a stop. If this causes danger or is not otherwise acceptable, stop the drive and machinery using the appropriate stop mode before activating the Safe torque off function.
- The Safe torque off function overrides all other functions of the drive.
- The Safe torque off function is ineffective against deliberate sabotage or misuse.
- The Safe torque off function has been designed to reduce the recognized hazardous conditions. In spite of this, it is not always possible to eliminate all potential hazards. The assembler of the machine must inform the final user about the residual risks.

## Maintenance

After the operation of the circuit is validated at start-up, the STO function shall be maintained by periodic proof testing. In high demand mode of operation, the maximum proof test interval is 20 years. In low demand mode of operation, the maximum proof test interval is 5 or 2 years; see section [Safety data](#) (page 274). It is assumed that all dangerous failures of the STO circuit are detected by the proof test. To perform the proof test, do the [Acceptance test procedure](#) (page 271).

**Note:** See also the Recommendation of Use CNB/M/11.050 (published by the European co-ordination of Notified Bodies) concerning dual-channel safety-related systems with electromechanical outputs:

- When the safety integrity requirement for the safety function is SIL 3 or PL e (cat. 3 or 4), the proof test for the function must be performed at least every month.
- When the safety integrity requirement for the safety function is SIL 2 (HFT = 1) or PL d (cat. 3), the proof test for the function must be performed at least every 12 months.

The STO function of the drive does not contain any electromechanical components.

In addition to proof testing, it is a good practice to check the operation of the function when other maintenance procedures are carried out on the machinery.

---

Include the Safe torque off operation test described above in the routine maintenance program of the machinery that the drive runs.

If any wiring or component change is needed after start up, or the parameters are restored, follow the test given in section [Acceptance test procedure](#) (page 271).

Use only ABB approved spare parts.

Record all maintenance and proof test activities in the machine logbook.

## ■ Competence

The maintenance and proof test activities of the safety function must be carried out by a competent person with adequate expertise and knowledge of the safety function as well as functional safety, as required by IEC 61508-1 clause 6.

## Fault tracing

The indications given during the normal operation of the Safe torque off function are selected by motor-side converter control program parameter 31.22.

The diagnostics of the Safe torque off function cross-compare the status of the two STO channels. In case the channels are not in the same state, a fault reaction function is performed and the drive trips on an “STO hardware failure” fault. An attempt to use the STO in a non-redundant manner, for example activating only one channel, will trigger the same reaction.

See the firmware manual of the motor-side converter control program for the indications generated by the drive, and for details on directing fault and warning indications to an output on the control unit for external diagnostics.

Any failures of the Safe torque off function must be reported to ABB.

## Safety data

The safety data for the Safe torque off function is given below.

**Note:** The safety data is calculated for redundant use, and does not apply if both STO channels are not used.

Frame	SIL/ SILCL	PL	SFF (%)	PFH (1/h)	PFD <sub>avg</sub> (T <sub>1</sub> = 2 a)	PFD <sub>avg</sub> (T <sub>1</sub> = 5 a)	MTTF <sub>D</sub> (a)	DC* (%)	SC	Cat.	HFT	CCF (%)	Mission time (T <sub>M</sub> )
R8	3	e	99.1	3.20E-09	2.66E-05	6.65E-05	10333	≥ 90	3	3	1	80	20
R11	3	e	99.66	3.65E-09	3.20E-05	8.00E-05	20219	≥ 90	3	3	1	80	20

3AXD1000006217 H, 3AXD10000481168 A

The following temperature profile is used in safety value calculations:

- 670 on/off cycles per year with  $\Delta T = 71.66 \text{ }^\circ\text{C}$
- 1340 on/off cycles per year with  $\Delta T = 61.66 \text{ }^\circ\text{C}$
- 30 on/off cycles per year with  $\Delta T = 10.0 \text{ }^\circ\text{C}$
- 32 °C board temperature at 2.0% of time
- 60 °C board temperature at 1.5% of time
- 85 °C board temperature at 2.3% of time.
- With frame size R8, the STO is a type A safety component as defined in IEC 61508-2. With frame size R11, the STO is type B.
- Relevant failure modes:
  - The STO trips spuriously (safe failure)

- The STO does not activate when requested  
A fault exclusion on the failure mode “short circuit on printed circuit board” has been made (EN 13849-2, table D.5). The analysis is based on an assumption that one failure occurs at one time. No accumulated failures have been analyzed.
- STO reaction time (shortest detectable break): 1 ms
- STO response time: R8: 2 ms (typical), 15 ms (maximum), R11: 2 ms (typical), 30 ms (maximum)
- Fault detection time: Channels in different states for longer than 200 ms
- Fault reaction time: Fault detection time + 10 ms
- STO fault indication (parameter 31.22) delay: < 500 ms
- STO warning indication (parameter 31.22) delay: < 1000 ms

## ■ Abbreviations

Abbr.	Reference	Description
Cat.	EN ISO 13849-1	Classification of the safety-related parts of a control system in respect of their resistance to faults and their subsequent behavior in the fault condition, and which is achieved by the structural arrangement of the parts, fault detection and/or by their reliability. The categories are: B, 1, 2, 3 and 4.
CCF	EN ISO 13849-1	Common cause failure (%)
DC	EN ISO 13849-1	Diagnostic coverage
HFT	IEC 61508	Hardware fault tolerance
MTTF <sub>D</sub>	EN ISO 13849-1	Mean time to dangerous failure: (The total number of life units) / (the number of dangerous, undetected failures) during a particular measurement interval under stated conditions
PFD <sub>avg</sub>	IEC 61508	Average probability of dangerous failure on demand
PFH	IEC 61508	Average frequency of dangerous failures per hour
PL	EN ISO 13849-1	Performance level. Levels a...e correspond to SIL
SC	IEC 61508	Systematic capability
SFF	IEC 61508	Safe failure fraction (%)
SIL	IEC 61508	Safety integrity level (1...3)
SILCL	IEC/EN 62061	Maximum SIL (level 1...3) that can be claimed for a safety function or subsystem
STO	IEC/EN 61800-5-2	Safe torque off
T <sub>1</sub>	IEC 61508-6	Proof test interval. T <sub>1</sub> is a parameter used to define the probabilistic failure rate (PFH or PFD) for the safety function or subsystem. Performing a proof test at a maximum interval of T <sub>1</sub> is required to keep the SIL capability valid. The same interval must be followed to keep the PL capability (EN ISO 13849) valid. See also section <a href="#">Maintenance</a> (page 273).
T <sub>M</sub>	EN ISO 13849-1	Period of time covering the intended use of a safety function/device. After the mission time, the safety device(s) must be replaced. Note that any T <sub>M</sub> values given cannot be regarded as a guarantee or warranty.



# 16

## Resistor braking

---

### Contents of this chapter

This chapter tells how to select, protect and wire brake choppers and resistors. The chapter also contains the related technical data.

### Operation principle and hardware description

The drive can be equipped with a brake chopper (option +D150) and brake resistors (option +D151) in own cubicles. The customer can also connect own brake resistors to the brake chopper.

The brake chopper handles the energy generated by a decelerating motor. The chopper connects the brake resistor to the intermediate DC circuit whenever the voltage in the circuit exceeds the limit defined by the control program. Energy consumption by the resistor losses lowers the voltage until the resistor can be disconnected.

### Selecting the default braking circuit components

1. Calculate the maximum power generated by the motor during braking ( $P_{\max}$ ).
  2. Select a suitable drive, brake chopper and brake resistor combination for the application, see section [Technical data](#) (page 283). The braking power of the chopper must be greater or equal than the maximum power generated by the motor during the braking ( $P_{\text{br,max}} \geq P_{\max}$ ).
-

## Planning a braking system with the factory-installed brake chopper and custom brake resistors

### ■ Verifying the capacity of the braking equipment

1. Calculate the maximum power generated by the motor during the braking ( $P_{\max}$ ).
2. See the ratings table on page 284. Make sure that the braking power of the chopper and drive combination ( $P_{\text{br,max}}$ ) is equal to or greater than  $P_{\max}$ .

**Note:** The  $P_{\text{br,max}}$  values in the ratings table are specified for the reference braking cycle of 1 minute braking and 9 minutes rest. If the braking cycle is different, make sure that, instead of  $P_{\text{br,max}}$ , the maximum allowed braking power ( $P_{\text{br}}$ ) is equal to or greater than  $P_{\max}$ . In the ratings table,  $P_{\text{br}}$  is given for two cycles. For other cycles, see section [Calculating the allowed maximum braking power for a custom braking cycle](#) on page 279.

3. To select the custom resistor, see section [Custom resistors](#) on page 278.
4. Check the resistor selection. The energy generated by the motor during a 600-second period must not exceed resistor heat dissipation capacity  $E_R$ .

**Note:** If the  $E_R$  of the resistor is not sufficient, it is possible to use a four-resistor assembly in which two resistors are connected in parallel, two in series. The  $E_R$  value of the four-resistor assembly is four times that of a single resistor.

### Custom resistors

Resistors other than those available as option +D151 can be used if

- the resistance is not smaller than the value given in the ratings table (page 284)



**WARNING!** Never use a brake resistor with a resistance smaller than the value specified for the particular drive / brake chopper / resistor combination. The drive and the chopper would not be able to handle the overcurrent caused by the small resistance.

- the resistance of the custom resistor does not restrict the braking capacity needed:

$$P_{\max} < \frac{U_{\text{DC}}^2}{R}$$

where

$P_{\max}$	Maximum power generated by the motor during braking
$U_{\text{DC}}$	Voltage over the resistor during braking. $U_{\text{DC}}$ equals 1.35 · 1.2 · 415 V DC (when supply voltage is 380 to 415 V AC) 1.35 · 1.2 · 500 V DC (when supply voltage is 440 to 500 V AC) or 1.35 · 1.2 · 690 V DC (when supply voltage is 525 to 690 AC)
$R$	Resistor resistance (ohm)

- the heat dissipation capacity  $E_R$  of the resistor is sufficient for the application (see step 4 above).
-

### Calculating the allowed maximum braking power for a custom braking cycle

The maximum allowed braking power for the customer braking cycle must meet both of the conditions 1 and 2. below.

1. The braking power of the custom braking cycle must not exceed the maximum braking power given in the table under [Ratings for the factory-installed brake choppers and resistors](#) on page 283:

$$P_{br} \leq P_{br,max}$$

2. The braking energy transferred during any 600-second period must be less than or equal to the energy that is transferred during the reference braking cycle:.

$$n \times P_{br} \times t_{br} \leq P_{br,max} \times 60 \text{ s}$$

where

- $n$  Number of the braking pulses during a 600-second period
- $P_{br}$  Maximum allowed braking power for the custom duty cycle in kW
- $t_{br}$  Braking time within the custom duty cycle in seconds
- $P_{br,max}$  Maximum braking power allowed for 40 seconds every 600 seconds. See the value in the table under [Ratings for the factory-installed brake choppers and resistors](#) on page 283.

#### Example 1

The duration of a braking cycle is 30 minutes. The braking time is 15 minutes.

**Result:** If the braking time exceeds 10 minutes, the braking is considered continuous. The allowed continuous braking power is 10% of the maximum braking power ( $P_{br,max}$ ).

#### Example 2

The duration of a braking cycle ( $T$ ) is three minutes. The braking time ( $t_{br}$ ) is 40 seconds.

$$1. \quad P_{br} \leq \frac{P_{br,max} \times 60 \text{ s}}{3 \times 40 \text{ s}} = 0.5 \times P_{br,max}$$

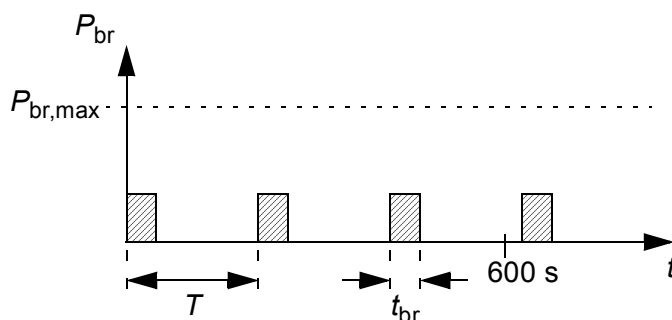

$$2. \quad P_{br} \leq P_{br,max}$$

**Result:** The maximum allowed braking power for the cycle is 50% of the rated value given for the reference cycle.

## ■ Selecting and routing the cables of a custom resistor

Use the same cable type for the resistor cabling as for the drive input cabling to make sure that the input fuses also protect the resistor cable. Alternatively, a two conductor shielded cable with the same cross-sectional area can be used.

### Minimizing electromagnetic interference

Follow these rules in order to minimize electromagnetic interference caused by the rapid current changes in the resistor cables:

- Shield the braking power line completely, either by using shielded cable or a metallic enclosure. Unshielded single-core cable can only be used if it is routed inside a cabinet that efficiently suppresses the radiated emissions.
- Install the cables away from other cable routes.
- Avoid long parallel runs with other cables. The minimum parallel cabling separation distance should be 0.3 meters (1 ft).
- Cross any other cables at right angles.
- Keep the cable as short as possible in order to minimize the radiated emissions and stress on chopper IGBTs. The longer the cable the higher the radiated emissions, inductive load and voltage peaks over the IGBT semiconductors of the brake chopper.

### Maximum cable length

The maximum length of the resistor cable(s) is 10 m (32.8 ft).

### EMC compliance of the complete installation

**Note:** ABB has not verified that the EMC requirements are fulfilled with custom brake resistors and cabling. The EMC compliance of the complete installation must be considered by the customer.

### Placing custom brake resistors

Install the resistors outside the drive in a place where they are able to cool effectively.

Arrange the cooling of the resistor in a way that

- no danger of overheating is caused to the resistor or nearby materials, and
- the temperature of the room the resistor is located in does not exceed the allowed maximum.

Supply the resistor with cooling air/water according to the resistor manufacturer's instructions.



**WARNING!** The materials near the brake resistor must be non-flammable. The surface temperature of the resistor is high. The temperature of the air flowing from the resistor is hundreds of degrees Celsius. If the exhaust vents are connected to a ventilation system, ensure that the materials withstand high temperatures. Protect the resistor against contact.

---

## ■ Protecting the system against thermal overload

The brake chopper protects itself and the resistor cables against thermal overload when the cables are dimensioned according to the nominal current of the drive. By default, a brake chopper fault is wired to stop the line-side converter of the drive.

---



### Thermal protection of the resistors

The standard resistors available as option +D151 are equipped with a thermal switch. The switches of the resistors are wired in series and connected to the Enable input of the brake chopper. The relay output of the chopper is wired to the line-side control unit so that a chopper fault condition stops the line-side converter.

With custom resistors, a similar protection must be implemented. Use cable rated as follows:

- twisted pair, shielding recommended
- rated operating voltage between a conductor and ground ( $U_0 \geq 750 \text{ V}$ )
- insulation test voltage  $> 2.5 \text{ kV}$ .

Keep the cable as short as possible.

### ■ Protecting the resistor cable against short-circuits

## Mechanical installation of custom brake resistors

Follow the resistor manufacturer's instructions.

## Electrical installation of custom brake resistors

### ■ Connection diagram

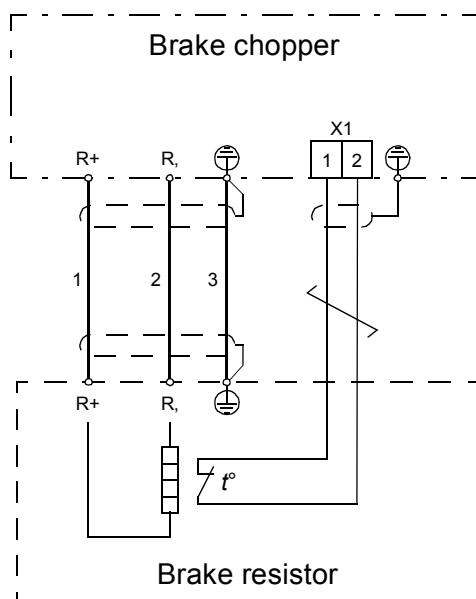

## ■ Connection procedure



**WARNING!** Obey the instructions in chapter [Safety instructions](#). If you ignore them, injury or death, or damage to the equipment can occur.

- Do the steps in section [Electrical safety precautions](#) (page 19) before you start the work.
- Connect the resistor cable at the resistor end only. If a shielded three-conductor cable with shield conductivity good enough for the protective earth (ground) conductor is used, cut off the third conductor. If the shield conductivity is not good enough, use the third conductor as the PE conductor. Ground the twisted shield of the cable as well as any separate PE conductor (if present).
- At the chopper end of the cable, connect the R+ and R- conductors of the resistor cable together. Measure the insulation resistance between the combined conductors and the PE conductor by using a measuring voltage of 1 kV DC. The insulation resistance must be higher than 1 Mohm.

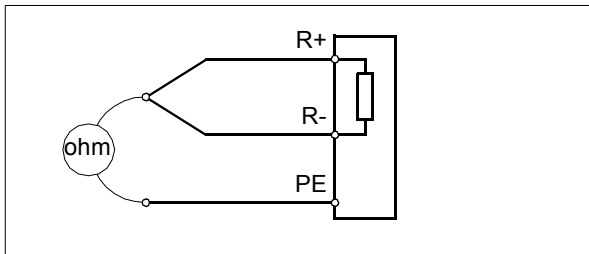

- Connect the resistor cable to the R+ and R- terminals of the chopper. If a shielded three-conductor cable with shield conductivity good enough for the protective earth (ground) conductor is used, cut off the third conductor. Ground the twisted shield of the cable as well as any separate PE conductor (if present).
- Connect the thermal switch of the brake resistor to the enable input (X1) on the brake chopper control board. Use cable specified under [Thermal protection of the resistors](#) (page 281). If there are multiple thermal switches, connect them in series.



**WARNING!** The ENABLE input terminal block of the brake chopper is at intermediate circuit potential when the line-side converter of the drive is running. This voltage is extremely dangerous and can cause serious damage or injury if the isolation level and protection conditions for the thermal switches are not sufficient. The thermal switches must always be properly insulated (over 2.5 kV) and shrouded against contact.

## Start-up

Check the settings of the following drive control program parameters (ACS880 primary control program):

- **30.30 Overvoltage control:** Overvoltage control disabled.

For settings of other control programs, see the appropriate firmware manual.

**Note:** New brake resistors may be coated with storage grease. As the brake chopper operates up for the first time, the grease on the resistors burns off. This can produce some smoke. Make sure there is sufficient ventilation.

## Technical data

### ■ Factory-installed brake chopper and resistor types

This table shows the brake chopper and resistor types of the drives.

$U_N$	ACS880-37 type	Brake chopper type (+D150)	Brake resistor type (+D151)
400 V	ACS880-37-0105A-3 ...	NBRA-658	2 x SAFUR210F575
	ACS880-37-0206A-3		
	ACS880-37-0293A-3 ...	NBRA-659	2 x SAFUR180F460
	ACS880-37-0650A-3		
500 V	ACS880-37-0101A-5 ...	NBRA-658	2 x SAFUR125F500
	ACS880-37-0180A-5		
	ACS880-37-0260A-5 ...	NBRA-659	2 x SAFUR200F500
	ACS880-37-0503A-5		
690 V	ACS880-37-0174A-7 ...	NBRA-669	2 x SAFUR200F500
	ACS880-37-0430A-7		

### ■ Ratings for the factory-installed brake choppers and resistors

This table shows the ratings for the factory installed brake chopper and resistor combinations with duty cycles of 10 seconds every 60 seconds and 1 minute every 5 minutes. For calculating the maximum allowed braking power with a custom duty cycle, see section [Calculating the maximum braking power for a custom duty cycle](#) (page 284).

$U_N$	Chopper type	Resistors	$R$ (ohm)	$P_{br,max}$ (kW) 40 s	$P_{br,cont}$ (kW)	$I_{max}$ (A)	Duty cycle (10/60 s)		Duty cycle (1/5 min)	
							$P_{br}$ (kW)	$I_{rms}$ (A)	$P_{br}$ (kW)	$I_{rms}$ (A)
400 V	NBRA-658	2 x SAFUR210F575	1.7	230	42	345	224	336	130	195
	NBRA-659	2 x SAFUR180F460	1.2	355	60	532	287	430	167	250
500 V	NBRA-658	2 x SAFUR125F500	2	268	36	334	192	239	111	138
	NBRA-659	2 x SAFUR200F500	1.35	403	54	502	287	357	167	208
690 V	NBRA-669	2 x SAFUR200F500	1.35	403	54	364	287	259	167	151

3AXD10000425795

$U_N$  Nominal voltage

$R$  Resistance of specified resistors. This is also the minimum allowed resistance of the resistor assembly.

$P_{br,max}$  Maximum braking power allowed for 40 seconds every 600 seconds.

$P_{br,cont}$  Maximum continuous braking power

$I_{max}$  Maximum current

$P_{br}$  Braking power for the specified duty cycle. Note: This value may be limited by  $P_{br,max}$ .

$I_{rms}$  rms current for the specified duty cycle

The ratings apply at an ambient temperature of 40 °C (104 °F).

### Calculating the maximum braking power for a custom duty cycle

The maximum allowed braking power for the customer braking cycle must meet both of the conditions 1 and 2. below.

1. The braking power of the custom duty cycle must not exceed the maximum braking power given in the table under [Ratings for factory-installed brake choppers and custom brake resistors](#) on page 284:

$$P_{br} \leq P_{br,max}$$

2. The braking energy transferred during any 600-second period must be less than or equal to the energy that is transferred during the reference braking cycle of 40 seconds every 600 seconds:.

$$n \times P_{br} \times t_{br} \leq P_{br,max} \times 40 \text{ s}$$

where

- n Number of the braking pulses during a 600-second period
- $P_{br}$  Maximum allowed braking power for the custom duty cycle in kW
- $t_{br}$  Braking time within the custom duty cycle in seconds
- $P_{br,max}$  Maximum braking power allowed for 40 seconds every 600 seconds. See the value in the table under [Ratings for factory-installed brake choppers and custom brake resistors](#) on page 284.

### ■ Ratings for factory-installed brake choppers and custom brake resistors

This table shows the ratings for the brake choppers (option +D150) with example duty cycles for custom resistor assemblies.

$U_N$	Chopper type	$P_{br,max}$ (kW)	$P_{cont}$ (kW)	$I_{max}$ (A)	$I_{rms}$ (A)	$R$ (ohm)	Duty cycle (10/60 s)		Duty cycle (1/5 min)		$U_{br,on}$ (V)	$U_{br,off}$ (V)	Air-flow (m <sup>3</sup> /h)
							$P_{br}$ (kW)	$I_{rms}$ (A)	$P_{br}$ (kW)	$I_{rms}$ (A)			
400 V	NBRA-658	230	70	384	109	1.7	230	355	230	355	674	660	660
	NBRA-659	353	96	545	149	1.2	353	545	303	468			
500 V	NBRA-658	268	81	380	101	2.15	268	331	268	331	811	795	
	NBRA-659	403	109	571	136	1.43	403	498	317	391			
690 V	NBRA-669	404	119	414	107	2.72	404	361	298	267	1120	1096	

3AXD10000425795

- $U_N$  Nominal voltage
- $P_{br,max}$  Maximum braking power allowed for 60 seconds minute every 600 seconds.
- $P_{cont}$  Maximum continuous braking power
- $I_{max}$  Maximum peak current
- $I_{rms}$  rms current
- $R$  Recommended resistance
- $P_{br}$  Braking power for the specified duty cycle.

$U_{br,on}$  DC voltage at which chopper starts conducting

$U_{br,off}$  DC voltage at which chopper stops conducting

The airflow is required for cooling the chopper.

■ **Terminals and cable entry data of factory-installed chopper/resistor cubicles**

See the dimension drawings delivered with the drive.

---



---

# Further information

## **Product and service inquiries**

Address any inquiries about the product to your local ABB representative, quoting the type designation and serial number of the unit in question. A listing of ABB sales, support and service contacts can be found by navigating to [abb.com/searchchannels](http://abb.com/searchchannels).

## **Product training**

For information on ABB product training, navigate to [new.abb.com/service/training](http://new.abb.com/service/training).

## **Providing feedback on ABB Drives manuals**

Your comments on our manuals are welcome. Navigate to [new.abb.com/drives/manuals-feedback-form](http://new.abb.com/drives/manuals-feedback-form).

## **Document library on the Internet**

You can find manuals and other product documents in PDF format on the Internet at [abb.com/drives/documents](http://abb.com/drives/documents).



[abb.com/drives](http://abb.com/drives)



ACS880-37 drives (45...400 kW, 60...450 hp) hardware manual